

**TECHNICAL MANUAL**

**AVIATION UNIT AND INTERMEDIATE  
MAINTENANCE MANUAL**

**ARMY MODEL  
AH-1P (PROD)  
AH-1E (ECAS)  
AH-1F (MODERNIZED COBRA)  
HELICOPTERS**

“Approved for public release; distribution is unlimited.”

---

**HEADQUARTERS, DEPARTMENT OF THE ARMY  
8 MAY 1980**



CHANGE

No. 14

HEADQUARTERS  
DEPARTMENT OF THE ARMY  
WASHINGTON, D.C., 30 April 1996

Aviation Unit and Intermediate  
Maintenance Manual

**ARMY MODEL  
AH-1P (PROD)  
AH-1E (ECAS)  
AH-1F (MODERNIZED COBRA)  
HELICOPTERS**

DISTRIBUTION STATEMENT A: Approved for public release; distribution is unlimited.

TM 55-1520-236-23-4, 8 May 1980, is changed as follows

1. Remove and insert pages as indicated below. New or changed text material is indicated by a vertical bar in the margin. An illustration change is indicated by a miniature pointing hand.

Remove pages	Insert pages
i and ii	i and ii
v and vi	v and vi
xix and xx	xix and xx
FO-98	FO-98
FO-109	FO-109

2. Retain this sheet in front of manual for reference purposes.

**By Order of the Secretary of the Army:**

Official:

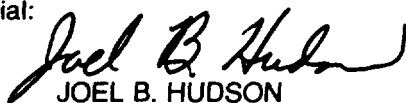
  
JOEL B. HUDSON

*Acting Administrative Assistant to the  
Secretary of the Army*

01546

DENNIS J. REIMER  
*General, United States Army  
Chief of Staff*

DISTRIBUTION:

To be distributed in accordance with DA Form 12-31-E, block no. 1149, requirements for TM 55-1520-236-23-4.



# URGENT

TM 55-1520-236-23-4  
C 13

CHANGE  
NO. 13

HEADQUARTERS  
DEPARTMENT OF THE ARMY  
WASHINGTON, D.C., 31 October 1995

Aviation Unit and Intermediate  
Maintenance Manual

**ARMY MODEL  
AH-1P (PROD)  
AH-1E (ECAS)  
AH-1F (MODERNIZED COBRA)  
HELICOPTERS**

DISTRIBUTION STATEMENT A: Approved for public release; distribution is unlimited

TM 55-1520-236-23-4, 8 May 1980, is changed as follows:

1. Remove and insert pages as indicated below. New or changed text material is indicated by a vertical bar in the margin. An illustration change is indicated by a miniature pointing hand.

Remove pages	Insert pages
i through vi	i through vi
vi.1/(vi.2 blank)	vi.1 and vi.2
vii and viii	vii and viii
viii.1/(viii.2 blank)	viii.1/(viii.2 blank)
ix and x	ix and x
x.1/(x.2 blank)	x.1/(x.2 blank)
xi and xii	xi and xii
-----	xii.1/(xii.2 blank)
xvii and xviii	xvii and xviii
xviii.1/(xviii.2 blank)	xviii.1 and xviii.2
xix through xxi/(xxii blank)	xix through xxii

2. Retain this sheet in front of manual for reference purposes

# URGENT

TM 55-1520-236-23-4  
C 13

By Order of the Secretary of the Army:

Official:

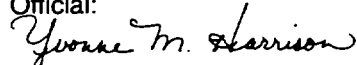

YVONNE M. HARRISON  
*Administrative Assistant to the  
Secretary of the Army*

00966

DENNIS J. REIMER  
*General, United States Army  
Chief of Staff*

**DISTRIBUTION:**

To be distributed in accordance with DA Form 12-31-E, block no. 1149, requirements for  
TM 55-1520-236-23-4.

CHANGE  
NO. 12

HEADQUARTERS  
DEPARTMENT OF THE ARMY  
WASHINGTON, D. C., 31 August 1994

Aviation Unit and Intermediate Maintenance Manual

**ARMY MODEL  
AH-1P (PROD)  
AH-1E (ECAS)  
AH-1F (MODERNIZED COBRA)  
HELICOPTERS**

DISTRIBUTION STATEMENT A: Approved for public release; distribution is unlimited

TM 55-1520-236-23-4, May 1980, is changed as follows:

1. Remove and insert pages as indicated below. New or changed text material is indicated by a vertical bar in the margin. An illustration change is indicated by a miniature pointing hand.

Remove pages	Insert pages
vi.1/(vi.2 blank)	vi.1/(vi.2 blank)
ix and x	ix and x
x.1 /(x.2 blank)	x.1/(x.2 blank)
xi and xii	xi and xii
xv and xvi	xv and xvi
xvii and xviii	xvii and xviii
xviii.1/(xviii. 2 blank)	xviii.1/(xviii.2 blank)
xix and xx	xix and xx
FO-42	FO-42
FO-53	FO-53
-----	FO-54.1 through FO-54.4
FO-63	FO-63
FO-82	FO-82
FO-83	FO-83
FO-85	FO-85

Remove pages

FO-88

FO-98

FO-104

FO-112

FO-121

FO-130

FO-138

Insert pages

FO-88

FO-98

FO-104

FO-112

FO-121

FO-130

FO-138

2. Retain this sheet in front of manual for reference purposes.

By Order of the Secretary of the Army:

Official:

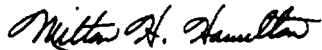

MILTON H. HAMILTON

*Administrative Assistant to the*

*Secretary of the Army*

07293

GORDON R. SULLIVAN  
*General, United States Army*  
*Chief of Staff*

DISTRIBUTION:

To be distributed in accordance with DA Form 12-31-E, block no. 1149, requirements for TM 55-1520-236-23-4.



CHANGE: }  
NO. 11 }

HEADQUARTERS  
DEPARTMENT OF THE ARMY  
WASHINGTON, D.C., 30 SEPTEMBER 1992

AVIATION UNIT AND INTERMEDIATE  
MAINTENANCE MANUAL

ARMY MODEL  
AH-1P (PROD)  
AH-1E (ECAS)  
AH-1F (MODERNIZED COBRA)  
HELICOPTERS

TM 55-1520-236-23-4, 8 May 1980, is changed as follows:

1. Remove and insert pages as indicated below. New or changed text material is indicated by a vertical bar in the margin. An illustration change is indicated by a miniature pointing hand.

Remove pages	Insert pages
xvii and xviii	xvii and xviii
xviii.1/xviii.2	xviii.1/xviii.2
FO-2	FO-2
FO-20	FO-20
FO-29	FO-29
FO-104	FO-104
FO-116	FO-116
FO-129	FO-129

2. Retain this sheet in front of manual for reference purposes.

By Order of the Secretary of the Army:

Official:

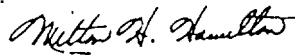

MILTON H. HAMILTON  
*Administrative Assistant to the  
Secretary of the Army*

02611

GORDON R. SULLIVAN  
*General, United States Army  
Chief of Staff*

DISTRIBUTION:

To be distributed in accordance with DA Form 12-31-E, block no 1149, requirements for TM 55-1520-236-23-4.

**DISTRIBUTION STATEMENT A: Approved for public release; distribution is unlimited.**



CHANGE }  
NO. 10 }

HEADQUARTERS  
DEPARTMENT OF THE ARMY  
WASHINGTON, D.C. 21 February 1991

AVIATION UNIT AND INTERMEDIATE  
MAINTENANCE MANUAL

ARMY MODEL  
AH-1P (PROD)  
AH-1E (ECAS)  
AH-1F (MODERNIZED COBRA)  
HELICOPTERS

TM 55-1520-236-23-4, 8 May 1980, is changed as follows:

1. Remove and insert pages as indicated below. New or changed text material is indicated by a vertical bar in the margin. An illustration change is indicated by a miniature pointing hand.

Remove pages	Insert pages
a and b	a and b
Introduction	Introduction
i through vi	i through vi
- - - - -	vi.1/vi.2
vii and viii	vii and viii
- - - - -	viii.1/viii.2
ix and x	ix and x
- - - - -	x.1/x.2
xi through xvi	xi through xvi
- - - - -	xvi.1/xvi.2
- - - - -	xviii.1/xviii.2
xix through xxii	xix through xxi/xxii
FO-2	FO-2
FO-42	FO-42
FO-53	FO-53
FO-82	FO-82
FO-83	FO-83
FO-85	FO-85
FO-88	FO-88
FO-104	FO-104
FO-138	FO-138
Cover 1/2	Cover 1/2

2. Retain this sheet in front of manual for reference purposes.

**TM 55-1520-236-23-4**  
**C 1 0**

**By Order of the Secretary of the Army:**

**Official:**

**THOMAS F. SIKORA**  
*Brigadier General, United States Army*  
*The Adjutant General*

**CARL E. VUONO**  
*General, United States Army*  
*Chief of Staff*

**DISTRIBUTION :**

To be distributed in accordance with DA Form 12-31-E, block no 1149, AVUM and AVIM maintenance requirements for TM 55-1520-236-23-4.

CHANGE }  
NO. 9 }

HEADQUARTERS  
DEPARTMENT OF THE ARMY  
WASHINGTON, D.C., 24 May 1990

AVIATION UNIT AND INTERMEDIATE  
MAINTENANCE MANUAL

ARMY MODEL  
AH-1P (PROD)  
AH-1E (ECAS)  
AH-1F (MODERNIZED COBRA)  
HELICOPTERS

TM 55-1520-236-23-4, 8 May 1980, is changed as follows:

1. Remove and insert pages as indicated below. New or changed text material is indicated by a vertical bar in the margin. An illustration change is indicated by a miniature pointing hand.

Remove pages

Insert pages

FO-119

FO-119

2. Retain this sheet in front of manual for reference purposes.

By Order of the Secretary of the Army:

official:

**CARL E. VUONO**  
*General, United States Army*  
*Chief of Staff*

**WILLIAM J. MEEHAN II**  
*Brigadier General, United States Army*  
*The Adjutant General*

DISTRIBUTION:

To be distributed in accordance with DA Form 12-31, AVUM and AVIM Maintenance requirements for AH-1F and AH-1P/E Helicopter, Attack.



CHANGE }  
 No. 8 }

HEADQUARTERS  
 DEPARTMENT OF THE ARMY  
 WASHINGTON D.C., 29 December 1988

Aviation Unit and Intermediate  
 Maintenance Manual

ARMY MODEL  
 AH-1P (PROD)  
 AH-1E (ECAS)  
 AH-1F (MODERNIZED COBRA)  
 HELICOPTERS

TM 55-1520-236-23-4, 8 May 1980, is changed as follows:

1. Remove and insert pages as indicated below. New or changed text material is indicated by a vertical bar in the margin. An illustration change is indicated by a miniature pointing hand.

Remove pages	Insert pages
xi and xii - - -	xi and xii xii.1/xii.2
xix through xxi/xxii - - -	xix through xxi/xxii FO-23.1

2. Retain this sheet in front of manual for reference purposes.

By Order of the Secretary of the Army:

Official:

**WILLIAM J. MEEHAN II**  
*Brigadier General, United States Army*  
*The Adjutant General*

**CARL E. VUONO**  
*General, United States Army*  
*Chief of Staff*

DISTRIBUTION:

To be distributed in accordance with DA Form 12-31, AVUM and AVIM Requirements for AH-1F and AH-1P/E Helicopter, Attack.





CHANGE }  
No. 7 }

HEADQUARTERS  
DEPARTMENT OF THE ARMY  
WASHINGTON, D.C., 2 December 1988

Aviation Unit and Intermediate  
Maintenance Manual

ARMY MODEL  
AH-1P (PROD)  
AH-1E (ECAS)  
AH-1F (MODERNIZED COBRA)  
HELICOPTERS

TM 55-1520-236-23-4, 6 May 1980, is changed as follows:

1. Remove and insert pages as indicated below. New or changed text material is indicated by a vertical bar in the margin. An illustration change is indicated by a miniature pointing hand.

Remove pages	Insert pages
c and d	c and d
- - -	FO-2.1/FO-2.2
FO- 10	FO-10
FO- 13	FO-13
FO-16	FO-16
FO-43	FO-43
FO-44	FO-44

2. Retain this sheet in front of manual for reference purposes.

By Order of the Secretary of the Army:

**CARL E. VUONO**  
*General, United States Army*  
*Chief of Staff*

Official:

**WILLIAM J. MEEHAN II**  
*Brigadier General, United States Army*  
*The Adjutant General*

DISTRIBUTION:

To be distributed in accordance with DA Form 12-31, AVUM and AVIM requirements for AH-1F Helicopter, Attack, and AH-1P/E Helicopter, Attack.



CHANGE: }  
NO. 6 }

HEADQUARTERS  
DEPARTMENT OF THE ARMY  
WASHINGTON, D.C., 18 July 1988

Aviation Unit and Intermediate  
Maintenance Manual

ARMY MODEL  
AH-1P (PROD)  
AH-1E (ECAS)  
AH-1F (MODERNIZED COBRA)  
HELICOPTERS

TM 55-1520-236-23-4, 8 May 1980, is changed as follows:

1. Remove and insert pages as indicated below. New or changed text material is indicated by a vertical bar in the margin. An illustration change is indicated by a miniature pointing hand.

Remove pages

iii through xxi/xxii  
FO-123

Insert pages

iii through xxii  
FO-123

2. Retain this sheet in front of manual for reference purposes.

**By Order of the Secretary of the Army:**

**CARL E. VUONO**  
**General, United States Army**  
***Chief of Staff***

**Official:**

**R. L. DILWORTH**  
***Brigadier General, United States Army***  
***The Adjutant General***

**DISTRIBUTION:**

To be distributed in accordance with DA Form 12-31, AVUM and AVIM Maintenance requirements for AH-1F, and AH-1P/E Helicopter, Attack.



CHANGE }  
NO. 5 }

HEADQUARTERS  
DEPARTMENT OF THE ARMY  
WASHINGTON, D.C., 31 August 1987

Aviation Unit and Intermediate  
Maintenance Manual

ARMY MODEL  
AH-1P(PROD)  
AH-1E(ECAS)  
AH-1F(MODERNIZED COBRA)  
HELICOPTERS

TM 55-1520-236-23-4, 8 May 1980, is changed as follows:

1. Title has been changed as stated above.
2. Remove and insert pages as indicated below. New or changed text material is indicated by a vertical bar in the margin. An illustration change is indicated by a miniature pointing hand.

Remove pages	Insert pages
FO-18	FO-18
FO-20	FO-20
-----	FO-21.1
-----	FO-22.1
FO-28	FO-28
FO-30	FO-30
FO-33	FO-33
-----	FO-50.1
- - - -	FO-51.1
FO-52	FO-52
FO-60	FO-60
FO-68 and FO-69	FO-68 and FO-69
-----	FO-81.1
FO-87	FO-87
FO-90	FO-90
FO-93	FO-93
-----	FO-100.1
-----	FO-101.1
-----	FO-102.1
FO-103	FO-103
FO-109	FO-109
FO-115	FO-115
FO-122	FO-122
FO-124	FO-124
FO-130	FO-130
FO-138	FO-138

- 3 . Retain these sheets in front of manual for reference purposes.

TM 55-1520-236-23-4  
C 5

By Order of the Secretary of the Army:

Official:

**CARL E. VUONO**  
*General, United States Army*  
*Chief of Staff*

**R. L. DILWORTH**  
*Brigadier General, United States Army*  
*The Adjutant General*

DISTRIBUTION:

To be distributed in accordance with DA Form 12-31, AVUM and AVIM Maintenance requirements for AH-1F and AH-1P/E Helicopter, Attack.

CHANGE }  
No. 4 }

HEADQUARTERS  
DEPARTMENT OF THE ARMY  
WASHINGTON, D.C., 22 April 1985

Aviation Unit and Intermediate  
Maintenance Manual

ARMY MODEL  
AH-1S(PROD)  
AH-1S(ECAS)  
AH-1S(MODERNIZED COBRA)  
HELICOPTERS

TM 55-1520-236-23-4, 8 May 1980, is changed as follows:

1. Remove and insert pages as indicated below. New or changed text material is indicated by a vertical bar in the margin. An illustration change is indicated by a miniature pointing hand.

Remove pages	Insert pages
FO-44	FO-44
FO-46 thru FO-48	FO-46 thru FO-48
FO-50 and FO-51	FO-50 and FO-51
FO-53 thru FO-55	FO-53 thru FO-55
FO-57 thru FO-64	FO-57 thru FO-64
FO-67 and FO-68	FO-67 and FO-68
FO-70 thru FO-72	FO-70 thru FO-72

2. Retain this sheet in front of manual for reference purposes.

By Order of the Secretary of the Army:

**JOHN A. WICKHAM, JR.**  
*General, United States Army*  
*Chief of Staff*

Official:

**DONALD J. DELANDRO**  
*Brigadier General, United States Army*  
*The Adjutant General*

DISTRIBUTION:

To be distributed in accordance with DA Form 12-31, Organizational, DS and GS Maintenance requirements for AH-1S(MOD COBRA) and AH-1S(PROD)(ECAS) aircraft.





# U R G E N T

TM 55-1520-236-23-4  
C3

CHANGE }  
NO. 3 }

HEADQUARTERS  
DEPARTMENT OF THE ARMY  
WASHINGTON, D.C., 2 November 1984

## Aviation Unit and Intermediate Maintenance Manual

ARMY MODEL  
AH-1S(PROD)  
AH-1S(ECAS)  
AH-1S(MODERNIZED COBRA)  
HELICOPTERS

TM 55-1520-236-23-4, 8 May 1980, is changed as follows:

1. Remove and insert pages as indicated below. New or changed text material is indicated by a vertical bar in the margin. An illustration change is indicated by a miniature pointing hand.

Remove pages

c/d

Insert pages

c and d

2. Retain this sheet in front of manual for reference purposes.

By order of the Secretary of the Army:

**JOHN A. WICKHAM, JR.**  
*General, United States Army*  
*Chief of Staff*

Official:

**ROBERT M. JOYCE**  
*Major General, United States Army*  
*The Adjutant General*

### DISTRIBUTION:

To be distributed in accordance with DA Form 12-31, Organizational, Direct Support, and General Support Maintenance requirements for AH-1S(MOD COBRA) and AH-1S(PROD)(ECAS) aircraft.

# U R G E N T



CHANGE }  
 NO. 2 }

HEADQUARTERS  
 DEPARTMENT OF THE ARMY  
 WASHINGTON, D.C., 12 October 1983

Aviation Unit and Intermediate  
 Maintenance Manual

ARMY MODEL  
 AH-IS (PROD)  
 AH-IS (ECAS)  
 AH-1S (MODERNIZED COBRA)  
 HELICOPTERS

TM 55-1520-236-23-4, 8 May 1980, is changed as follows:

NOTICE

When the following list of changes on TM 55-1520-236-23-Series manuals are received and incorporated into manuals they will supersede the TM 55-1520-239-23-Series manuals.

- TM 55-1520-236-23-1, Changes 1 through 13
- TM 55-1520-236-23-2, Changes 1 through 3
- TM 55-1520-236-23-3, Changes 1 and 2
- TM 55-1520-236-23-4, Changes 1 and 2

1. Remove and insert pages as indicated below.

Remove pages

Insert pages

Fold Outs

FO-87

FO-87

2. New or changed text material is indicated by a vertical bar in the margin. An illustration change is indicated by a miniature pointing hand.

3. Retain this sheet in front of manual for reference purposes.

By Order of the Secretary of the Army:

**JOHN A. WICKHAM, JR.**  
*General, United States Army*  
*Chief of Staff*

Official:

**ROBERT M. JOYCE**  
*Major General, United States Army*  
*The Adjutant General*

DISTRIBUTION:

To be distributed in accordance with DA Form 12-31, Organizational Maintenance requirements for AH-IS (PROD) aircraft.



CHANGE

No. 1

HEADQUARTERS  
DEPARTMENT OF THE ARMY  
WASHINGTON, D.C., 10 September 1982

Aviation Unit and Intermediate  
Maintenance Manual

ARMY MODEL  
AH-1S(PROD)  
AH-1S(ECAS)  
AH-1S(MODERNIZED COBRA)  
HELICOPTERS

TM 55-1520-236-23-4, 8 May 1980, is changed as follows:

1. Remove and insert pages as indicated below.

	Remove pages	Insert pages
Table of Contents	i thru iii/iv	i thru xxi/xxii
Fold Outs	FO-48	FO-48
	FO-66	FO-66
	FO-98	FO-98
	FO-130	FO-130
	FO-134 thru FO-136	FO-134 thru FO-136

2. New or changed text material is indicated by a vertical bar in the margin. An illustration change is indicated by a miniature pointing hand.

3. Retain this sheet in front of manual for reference purposes.

**By Order of the Secretary of the Army:**

**E. C. MEYER**  
*General, United States Army*  
*Chief of Staff*

**Official:**

**ROBERT M. JOYCE**  
*Brigadier General, United States Army*  
*The Adjutant General*

**DISTRIBUTION:**

To be distributed in accordance with DA Form 12-31, Organizational Maintenance Requirements for AH-1S(PROD) aircraft.



**WARNING**

Personnel performing operations, procedures, and practices which are included or implied in this technical manual shall observe the following warnings. Disregard of these warnings and precautionary information can cause serious injury, or death.

Warnings, cautions, and notes are used to emphasize important and critical instructions and shall be used for the following conditions:

**WARNING**

An operating procedure, practice, etc., which, if not correctly followed, could result in personal injury or loss of life.

**CAUTION**

An operating procedure, practice, etc., which if not strictly observed, could result in damage to or destruction of equipment.

**NOTE**

An operating procedure, condition, etc., which it is essential to highlight.

**STARTING ENGINE**

Starting and Operation  
of the helicopter will be performed only by  
authorized personnel in accordance with AR 95-1.

**HIGH VOLTAGE**

The helicopter should be electrically grounded when parked.  
Turn off all power switches before making electrical connections or disconnections.  
Serious burns and electrical shock can result from contact  
with exposed electrical wires or connectors.

**RADIATION HAZARD**

Self-luminous dials contain radioactive materials.  
If such an instrument is broken or becomes unsealed, avoid personal contact.  
Use forceps or gloves made of rubber or polyethylene to pick up contaminated material.  
Place material and gloves in a plastic bag.  
Seal bag and dispose of it as radioactive waste  
in accordance with AR 755-15 and TM 3-261 (TB 43-0108).  
Repair procedures shall conform to requirements in AR 700-52.

### **DANGEROUS CHEMICALS**

Exposure to high concentrations of fire extinguishing agents can cause severe irritation of eyes and nose,

Corrosive Battery Electrolyte (Potassium Hydroxide). Wear rubber gloves, apron, and face shield when handling leaking batteries. If potassium hydroxide is spilled on clothing, or other material, wash immediately with clean water. If spilled on personnel, immediately start flushing the affected area with clean water. Continue washing until medical assistance arrives.

Use solvents or chemicals in a well ventilated area. Do not inhale vapors or allow to come in contact with skin or eyes. Observe proper fire prevention rules.

### **LASER LIGHT**

The laser beam is dangerous and can cause blindness if it enters the eye either directly or reflected from a shiny surface. Crewmen shall wear approved laser protective visors whenever in controlled area when laser rangefinder or laser target designators are being used. Laser shall be used only in controlled areas by qualified personnel.

### **NOISE LEVEL**

Sound pressure levels in the helicopter during some operating conditions exceed the Surgeon General's hearing conservation criteria as defined in TB MED 251. Hearing, protection devices, such as the aviator helmet or ear plugs, are required to be worn by all personnel in and around the helicopter during its operation.

### **ASBESTOS FIBERS**

Avoid creating dust, Breathing asbestos dust may cause serious bodily harm.

### **ARMAMENT**

When working on, or near an armed helicopter, take all possible precautions to avoid accidental firing of armament. Personnel shall not occupy possible firing pattern in front of or up to 20 feet behind rocket pods.

Munitions shall be handled by authorized personnel only. All weapons shall be dry-fired. Only dummy ammunition with smooth cases like live ammunition shall be used.



### **JETTISON**

All ground safety pins must be removed before flight. Failure to do so will prevent emergency jettison of stores.

Jettison circuit may be activated with BAT" switch OFF and pilot WING STORES JTSN circuit breaker OPEN. For positive deactivation of jettison circuit, open both the PLT JTSN and GNR JTSN circuit breakers located in the pilot's side console. Serious injury can result from accidental ground jettison.

### **SANDING DUST**

Sanding on reinforced laminated glass produces fine dust that may cause skin irritations. Observe necessary protective measures.

### **TRANSMISSION LEVELING**

Do not attempt to level transmission with "Jacks Only." Hoist must be used in conjunction with jacks while lifting transmission.

### **EXTERNAL STORES**

Prior to any helicopter maintenance functions that require external stores be removed JETTISON cartridge shall be removed. Remove jettison cartridges from pylon stores ejection device prior to placing helicopter in a hangar, to prevent injury to personnel and damage to equipment. Exception: Removal is not necessary when helicopter is to be placed in hangar for short-term, providing both PLT JTSN and GNR JTSN circuit breakers in the pilot's side console are OPEN, and warning signs indicate that helicopter has an armed jettison system.

### **CANOPY REMOVAL SYSTEM**

Ground safety pins must be installed in pilot and gunner arming/firing handles of canopy removal system whenever the helicopter is on the ground. Pins should be installed by crew.

### **CLEANING HYDRAULIC COMPONENTS**

The use of any alcohol in cleaning components which contact hydraulic fluids is prohibited. Formation of a polymeric residue can result, which could impair mechanical operation of the component.

### **HANDLING HYDRAULIC FLUID (MIL-H-83282)**

When handling hydraulic fluid (MIL-H-83282), Table 1-3, Item 61, observe the following

- Prolonged contact with liquid or mist can irritate eyes and skin.
- After any prolonged contact with skin, immediately wash contacted area with soap and water. If liquid contacts eyes, flush them immediately with clear water.
- If liquid is swallowed, do not induce vomiting get immediate medical attention.
- Wear rubber gloves when handling liquid. If prolonged contact with mist is likely, wear an appropriate respirator.
- When fluid is decomposed by heating, toxic gases are released.

### **EPOXY BASED ADHESIVE**

Epoxy based adhesive, P/N EA934, contains an asbestos filler which could be inhaled or ingested during grinding, cutting, or sanding operations on cured epoxy material.

### **TOOLS**

Use only chrome plated steel or unplated steel tools for disassembly or reassembly procedures described in this manual. Use of cadmium or zinc plated tools is not permitted.

### **GROUNDING**

All aircraft parked outside will be grounded and bonded, in accordance with FM 1-500, to the aerospace ground equipment while servicing, i.e., fueling or defueling, arming (ammunition or explosives), oxygen, hydraulic fluids or any flammable liquids. Grounding is not necessary for aircraft parked outside unless one of the above is being accomplished.

### **INSPECTION OF REMOVED COMPONENT'S**

When components are being removed from an aircraft, all inspections required by the next phase maintenance inspection must be accomplished prior to either immediate re-use or storage. Upon installation, the component will be inspected in accordance with the current phase either that phase the receiving aircraft is in or if in between phase, the last phase performed). This will ensure that a re-used component will not overfly any PM inspections, and that it will be properly interfaced with the receiving aircraft phase sequence.

**TECHNICAL MANUAL**

No. 55-1520-236-23-4

**HEADQUARTERS  
DEPARTMENT OF THE ARMY  
WASHINGTON, D.C., 8 May 1980**

**Aviation Unit and Intermediate  
Maintenance Manual**

**ARMY MODEL  
AH-1P (PROD)  
AH-1E (ECAS)  
AH-1F (MODERNIZED COBRA)**

**HELICOPTERS**

**NOTE**

This manual is printed in five volumes, as follows:

TM 55-1520-236-23-1, consisting of Table of Contents, Preface Chapters 1 through 6.

TM 55-1520-236-23-2, consisting of Table of Contents. Chapters 7 through 17. Appendix A through C.

TM 55-1520-236-23-3, consisting of Table of Contents, Appendix D through G, and Index.

TM 55-1520-236-23-4, consisting of Table of Contents, FO-1 through FO-142.

TM 55-1520-236-23-5, consisting of Table of Contents, FO-143 through FO-145.

The Preface, Appendices and Index are applicable to all volumes.

**\*This manual together with TM 55-1520 -236-23-1,8 May 1980, TM 55-1520 -236-23-2,8 May 1980, TM 55-1520-236-23-3,8 May 1980, and TM 55-1520-236-23-5,31 July 1990, supersedes TM 55-1520-236-23-1,30 June 1977 and TM 55-1520-236-23-2,30 June 1977.**



TECHNICAL MANUAL  
NO. 55-1520-236-23

HEADQUARTERS  
DEPARTMENT OF THE ARMY  
WASHINGTON, D.C., 8 May 1980

AVIATION UNIT AND INTERMEDIATE MAINTENANCE MANUAL  
ARMY MODEL

AH-1P (PROD)  
AH-1E (ECAS)  
AH-1F (MODERNIZED COBRA)  
HELICOPTERS

**REPORTING ERRORS AND RECOMMENDING IMPROVEMENTS**

You can help Improve this manual. If you find any mistakes or if you know of a way to improve these procedures, please let us know. Mail your letter or DA Form 2028 (Recommended Changes to Publications and Blank Forms), or DA Form 2028-2 located in the back of this manual directly to: Commander, US Army Aviation and Troop Command, ATTN: AMSAT-I-MP, 4300 Goodfellow Blvd., St. Louis, MO 63120-1798. A reply will be furnished directly to you.

DISTRIBUTION STATEMENT A: Approved for public release; distribution is unlimited

**TABLE OF CONTENTS**

		<b>PARAGRAPH</b>	<b>PAGE</b>
<b>VOLUME 1</b>			
CHAPTER 1	<b>AIRCRAFT GENERAL</b>		
Section I	<b>Servicing</b> .....	1-1	1-1
Section II	<b>Lubrication</b> .....	1-28	1-41
Section III	<b>Handling, jacking, mooring, hoisting, and sling loading</b> .....	1-30	1-45
Section IV	<b>Inspection requirements</b> .....	1-55	1-58
Section V	<b>Overhaul and retirement schedule</b> .....	1-58	1-87
Section VI	<b>Flight safety critical aircraft parts (FSCAP) program</b> .....	1-59	1-89
CHAPTER 2	<b>AIRFRAME</b>		
Section I	<b>Structural repair</b> .....	2-1	2-1
Section II	<b>Fuselage</b> .....	2-41	2-113
Section III	<b>Tailboom</b> .....	2-281	2-229
Section IV	<b>Wing</b> .....	2-335	2-245
Section V	<b>Deleted</b> .....	2-352	2-258
CHAPTER 3	<b>LANDING GEAR</b>		
Section I	<b>Landing Gear</b> .....	3-1	3-1
Section II	<b>Skids/Struts (Not Applicable)</b> .....		3-29
Section III	<b>Floats (Not Applicable)</b> .....		3-29
Section IV	<b>Skis (Not Applicable)</b> .....		3-29
Section V	<b>Brakes (Not Applicable)</b> .....		3-29
CHAPTER 4	<b>POWER PLANT</b>		
Section I	<b>Power plant</b> .....	4-1	4-1
Section II	<b>Cooling system (Not Applicable)</b> .....		4-17

		PARAGRAPH	PAGE
Section III	<b>Air induction system</b> .....	4-24	4-18
Section IV	<b>Exhaust system</b> .....	4-39	4-36
Section V	<b>Oil system</b> .....	4-59	4-50.2
Section VI	<b>Ignition system (Not Applicable)</b> .....		4-69
Section VII	<b>Power lever controls</b> .....	4-98	4-69
Section VIII	<b>Quick change assembly</b> .....	4-114	4-79
<b>CHAPTER 5</b>	<b>ROTORS</b>		
Section I	<b>Main rotor system</b> .....	5-3	5-1
Section II	<b>Main rotor hub and blades</b> .....	5-8	5-2.2
Section III	<b>Main rotor controls</b> .....	5-47	5-103
Section IV	<b>Tail rotor system</b> .....	5-72	5-138
Section V	<b>Tail rotor hub and blade assembly</b> .....	5-79	5-141
Section VI	<b>Tail rotor hub and controls</b> .....	5-89	5-148
Section VII	<b>Tail rotor blades</b> .....	5-107	5-170
Section VIII	<b>Tracking and balancing procedures</b> .....	5-114	5-181
<b>CHAPTER 6</b>	<b>DRIVE TRAIN SYSTEM</b>		
Section I	<b>Drive train</b> .....	6-1	6-1
Section II	<b>Main driveshaft</b> .....	6-5	6-7
Section III	<b>Main transmission</b> .....	6-20	6-24
Section IV	<b>Tail rotor driveshaft</b> .....	6-75	6-75
Section V	<b>Intermediate gearbox</b> .....	6-96	6-86
Section VI	<b>Tail rotor gearbox</b> .....	6-113	6-103
Section VII	<b>Transmission oil system</b> .....	6-129	6-120.1
<b>VOLUME II</b>			
<b>CHAPTER 7</b>	<b>HYDRAULIC AND PNEUMATIC SYSTEMS</b>		7-1
<b>CHAPTER 8</b>	<b>INSTRUMENTS SYSTEM</b>		
Section I	<b>Instrument maintenance</b> .....	8-1	8-1
Section II	<b>Engine instruments</b> .....	8-10	8-7
Section III	<b>Flight instruments</b> .....	8-114	8-25
Section IV	<b>Navigation instruments</b> .....	8-185	8-36
Section V	<b>Miscellaneous instruments</b> .....	8-198	8-38
Section VI	<b>Instrument panels</b> .....	8-285	8-52
<b>CHAPTER 9</b>	<b>ELECTRICAL SYSTEMS</b>		
Section I	<b>Electrical systems maintenance</b> .....	9-1	9-1
Section II	<b>Direct current power distribution system</b> .....	9-37	9-27
Section III	<b>Alternating current power distribution system</b> .....	9-119	9-56
Section IV	<b>Starting system</b> .....	9-238	9-73
Section V	<b>Ignition system</b> .....	9-246	9-75
Section VI	<b>Lighting provisions</b> .....	9-254	9-76
Section VII	<b>Miscellaneous equipment</b> .....	9-340	9-102
Section VIII	<b>P Armament systems circuitry</b> .....	9-412	9-122

	PARAGRAPH	PAGE
Section IX <b>E</b> Armament systems circuitry .....	9-442	9-154
Section X <b>M</b> Armament and fire control systems circuitry .....	9-496	9-185
<b>CHAPTER 10 FUEL SYSTEMS</b>		
Section I Fuel systems .....	10-1	10-1
Section II Fuel cells .....	10-73	10-17
<b>CHAPTER 11 FLIGHT CONTROLS</b>		
Section I Flight controls .....	11-1	11-1
Section II Flight controls components .....	11-145	11-81
<b>CHAPTER 12 UTILITY SYSTEMS</b>		
Section I Fire detection system .....	12-1	12-1
Section II Rain removal system .....	12-9	12-4
Section III Defroster system .....	12-10	12-4
Section IV Low G Warning System .....	12-11	12-5
<b>CHAPTER 13 ENVIRONMENTAL CONTROL SYSTEM</b>		
Section I Heating systems .....	13-1	13-1
Section II Air cooling systems .....	13-125	13-37
<b>CHAPTER 14 HOIST AND WINCHES (Not Applicable) .....</b>	14-1	14-1
<b>CHAPTER 15 AUXILIARY POWER PLANT (Not Applicable) .....</b>	15-1	15-1
<b>CHAPTER 16 MISSION EQUIPMENT .....</b>	16-1	16-1
<b>CHAPTER 17 EMERGENCY EQUIPMENT .....</b>	17-1	17-1
<b>APPENDIX A REFERENCES .....</b>		A-1
<b>APPENDIX B MAINTENANCE ALLOCATION CHART .....</b>		B-1
<b>APPENDIX C AIRCRAFT INVENTORY MASTER GUIDE .....</b>		C-1
<b>VOLUME III</b>		
<b>APPENDIX D ILLUSTRATED FIELD MANUFACTURE LIST .....</b>		D-1
<b>APPENDIX E STORAGE OF AIRCRAFT</b>		
Section I General information .....	E-1	E-1
Section II Flyable storage .....	E-6	E-2
Section III Short term storage .....	E-10	E-4
Section IV Intermediate storage .....	E-14	E-11
<b>APPENDIX F WIRING DIAGRAMS .....</b>		F-1
<b>APPENDIX G WIRE LISTS .....</b>		G-1
<b>INDEX .....</b>		Index-1
<b>VOLUME IV</b>		
<b>FOLDOUTS .....</b>		FO-1
<b>VOLUME V</b>		
<b>FOLDOUTS .....</b>		FO-143

## LIST OF ILLUSTRATIONS

NUMBER	TITLE	PAGE
1-1	Servicing Points Diagram .....	1-2
1-1.1	Receiver and Cap Assembly .....	1-2.3
1-2	Deleted	
1-3	Deleted	
1-4	Deleted	
1-5	Lubrication Chart .....	1-42
1-6	Ground Handling Diagram .....	1-46
1-7	Work Aid for Towing Ground Handling Gear .....	1-48
1-8	Jacking and Mooring Fittings .....	1-50
1-9	Covers Diagram .....	1-53
1-9.1	AH-1 Paved Surface Mooring Configuration .....	1-54.2
1-10	Mooring Diagram .....	1-55
1-11	Maintenance Hoist, T101520 .....	1-57
1-12	Inspection Area Diagram (Typical) .....	1-59
2-1	Fuselage Components and Tailboom .....	2-2.1
2-2	Structural Panels .....	2-4
2-3	Non-Structural Access Panels, Doors, and Fairings .....	2-8
2-4	Principal Dimensions - Airframe .....	2-14
2-5	Reference Lines - Airframe .....	2-16
2-6	Cleaning Chart .....	2-23
2-7	Type A - Damage, Body Panel Repairs .....	2-36
2-8	Type B - Damage, Body Panel Repairs .....	2-37
2-9	Type C - Damage, Body Panel Repairs .....	2-38
2-10	Type D - Damage, Body Panel Repairs .....	2-40
2-11	Primary Structural Caps - Left Side .....	2-42
2-12	Primary Structural Caps - Right Side .....	2-43
2-13	Pilot and Gunner Floor Panels .....	2-44
2-14	Bulkhead at Station 93.0 .....	2-45
2-15	Bulkhead at Station 148.5 and 171.61 .....	2-46
2-15.1	Ammo Floor Scuff Doubler Installation .....	2-46.1
2-16	Bulkhead at Stations 186.25 and 213.94 .....	2-47
2-17	Bulkhead at Stations 250.0 and 268.5 .....	2-48
2-18	R&L Main Beam Panels at Station 148.5 to 186.25 .....	2-49
2-19	R&L Main Beam Panels at Station 213.94 to 250.0 .....	2-50
2-20	Panel at Forward Fuel Cell at R.S. and Gunner Floor .....	2-51
2-21	R&L Beam Panels at Station 250 to B.S. 41.32 .....	2-52
2-22	Ammo Floor, Support Panel and Forward Fuel Cell Panel at Station 213.9 .....	2-53
2-23	Forward Fuel Cell Floor - Lower Panel Station 86 to 213 .....	2-54
2-24	Lower Aft Fuel Cell Panel at Station 250 to B.S. 41.32 .....	2-55
2-25	Engine Deck Installation at Station 213.94 to 298.75 .....	2-56
2-26	Forward Fuel Cell Panels - Main Beam at Station 186 to 214 .....	2-57
2-27	Edge Repair for Honeycomb Panels with Glass Skin Opposite Titanium .....	2-58
2-28	Edge Repair for Honeycomb Panels with Aluminum Alloy with Glass Edging .....	2-60
2-29	Edge Repair for Honeycomb Panels with Glass Finish at Channel .....	2-61
2-30	Typical Rivet Pattern for Channel Section Repair .....	2-62
2-31	Potted - Injection - Grommet Type Fasteners .....	2-64
2-31.1	HMPP Cowling Nut Plate Replacement .....	2-66.1
2-31.2	Stringer Repair .....	2-66.2
2-32	Longeron Damage Limits .....	2-82
2-33	Typical Tailboom Bulkhead Damage Limits .....	2-85
2-34	Tail Rotor Driveshaft Covers .....	2-87
2-35	Driveshaft Cover Hinges and Angles Damage .....	2-88
2-36	Damage Limits - Tailboom Attach Fitting .....	2-89
2-37	Damage Limits - Bearing Hanger Support Fitting .....	2-90



LIST OF ILLUSTRATIONS (CON'T)

NUMBER	TITLE	PAGE
2-38	Damage Limits - Intermediate Gearbox Support Installation .....	2-91
2-39	Damage Limits - Tail Rotor Drive Support Fitting .....	2-92
2-40	Vertical Fin Honeycomb Panels Damage .....	2-96
2-41	Edge Repair on Vertical Fin .....	2-100
2-42	Tailboom Longerons .....	2-101
2-43	Longeron Repair .....	2-102
2-43.1	Longeron Material Chart .....	2-104
2-44	Damage Skin, Frame, and Bulkhead Repair .....	2-104.1
2-45	Repair - Damaged Ribs - Bulkhead .....	2-105
2-46	Repair - Bulkhead Flanged Member .....	2-106
2-46.1	Tailboom Structural Material .....	2-106.1
2-47	Repair - Bulkhead "T" Cap - Extensive Damage .....	2-107
2-48	Injection Tape Fastener (Insert) in Vertical Fin Panel .....	2-111
2-48.1	Vertical Fin Ballast Weight Panel .....	2-112.2
2-49	Sheet Metal Panels and Skin .....	2-115
2-50	<b>I</b> <b>I</b> Fairing - Cowling for Pylon, Transmission, Engine, and Tailpipe .....	2-123
2-51	<b>VI</b> Fairing and Cowling - Pylon, Transmission, Engine and IR Suppressor .....	2-126
2-52	IR Suppressor Cowling Installation .....	2-132
2-53	Firewalls and Driveshaft Fireshield Installation .....	2-139
2-54	Forward Engine Firewall Assembly (Prior to Incorporation of MWO 55-1520-236-50-12) .....	2-142
2-54.1	<b>I</b> <b>VI</b> Forward Engine Firewall Assembly (After Incorporation of MWO 55-1520-236-50-12) .....	2-144.3
2-55	Aft Engine Firewall and Cowl Support .....	2-146
2-56	Tail Rotor Driveshaft Fireshield Assembly .....	2-152
2-57	Engine Air Induction Baffle Installation (Prior to Incorporation of MWO 55-1520-236-50-12) ....	2-154
2-57.1	<b>I</b> <b>VI</b> Centrisep Particle Separator Engine Air Induction Baffle Installation (After Incorporation of MWO 55-1520-236-50-12) .....	2-154.1
2-58	Engine Air Induction Baffle Assembly (Prior to Incorporation of MWO 55-1520-236-50-12) .....	2-155
2-58.1	<b>I</b> <b>VI</b> Centrisep Particle Separator Engine Air Induction Baffle Assembly (After Incorporation of MWO 55-1520-236-50-12) .....	2-158.1
2-59	Pilot Door - Installation .....	2-161
2-60	Gunner Door - Installation .....	2-164
2-61	Pilot Door - Assembly .....	2-167
2-62	Gunner Door - Assembly .....	2-169
2-63	Gunner Door Latch Assembly .....	2-170
2-64	Canopy Window and Windshield - Installation .....	2-176
2-65	Canopy Frame - Installation .....	2-178
2-66	Pilot Seat - Installation .....	2-179
2-67	Gunner Seat - Installation .....	2-180
2-68	Pilot Seat - Assembly .....	2-183
2-69	Engine Armor - Installation .....	2-188
2-70	Soundproofing Blanket - Installation .....	2-190.1
2-70.1	Wire Strike Protection System .....	2-190.2
2-70.2	Damage Limits - Wire Strike Deflector .....	2-191
2-71	Engine Mount Installation .....	2-192
2-72	Damage Limits - Aft Engine Mount Assembly (Tripod) .....	2-196
2-73	Damage Limits - Fittings for Aft Engine Mount (Tripod) .....	2-199
2-74	Aft Engine Mount (Tripod) Assembly .....	2-200
2-75	Damage Limits - Engine Mount Pillow Blocks (Left and Right) .....	2-202
2-76	Diagonal Brace Tube - Installation .....	2-204
2-77	Pylon Support - Installation .....	2-206
2-77.1	Pylon Mount Bolt Inspection Criteria .....	2-206.1

LIST OF ILLUSTRATIONS (CON'T)

NUMBER	TITLE	PAGE
2-78	Access Hole for Damper to Damper Support Fitting Mount Bolts .....	2-209
2-79	Fifth Mount and Fifth Mount Support Fitting - Installation .....	2-210
2-79.1	Bushing and Bearing Tool Kit LT-40 .....	2-212.2
2-79.2	Fifth Mount Assembly .....	2-212.3
2-79.3	Fifth Mount Bushing and Bearing Removal .....	2-212.3
2-79.4	Fifth Mount Bushing and Bearing Installation .....	2-212.4
2-79.5	Fifth Mount Bush Staking .....	2-212.4
2-80	Damper - Internal Yielding Inspection .....	2-214
2-81	Transmission Damper - Assembly .....	2-215
2-82	Damper Seal - Installation Tool .....	2-216
2-83	Damper Barrel Shim - Replacement .....	2-217
2-84	Damper Upper Shim - Replacement .....	2-218
2-85	Damper Lower Shim - Replacement .....	2-219
2-86	Hydraulic Fitting Supports - Installation .....	2-221
2-87	Damper Support Fitting - Elongated Holes .....	2-223
2-88	Damage Limits - Fifth Mount Support Fitting .....	2-224
2-89	Tow, Jack, and Mooring Fitting .....	2-226
2-90	Aft Section Assembly .....	2-230
2-91	Tail Boom Support Stand - Workaid .....	2-231
2-92	Tailboom Installation .....	2-232
2-92.1	Tailboom Installation .....	2-232.1
2-93	Tailboom and Elevator Skins .....	2-234
2-94	Tailboom and Synchronized Elevator - Structure .....	2-237
2-95	Tailskid - Installation .....	2-240
2-96	Aft Ballast - Installation .....	2-242
2-97	Synchronized Elevators - Installation .....	2-244
2-98	Wing Assembly - Installation .....	2-246
2-99	Wing Bushings - Limits Chart .....	2-250
2-100	Wing Skin Repair (External Hole) .....	2-251
2-101	Wing Skin Repair (External Crack) .....	2-252
2-102	Wing Skin Repair (Close to Frame, Spar, or Ribs) .....	2-253
2-103	Wing Skins, Fairings, Covers, Doors .....	2-254
2-104	Wing Fairing Repair (Leading - Trailing Edge) .....	2-256
2-105	Deleted	
3-1	Landing Gear and Support Installation .....	3-2
3-1.1	Crosstube Shim Fabrication .....	3-4.1
3-2	Crosstube - Deflection Inspection .....	3-5
3-3	Damage Limits - Crosstubes .....	3-6
3-4	Skid Tube - Repairs .....	3-9
3-4.1	Skid Shoes - Standard, Heavy Duty .....	3-10.2
3-5	Crosstube Fairing Assembly .....	3-12
3-6	Landing Gear Support Spacer Installation .....	3-15

## LIST OF ILLUSTRATIONS (CON'T)

NUMBER	TITLE	PAGE
3-7	Ground Handling Gear - Assembly .....	3-17
3-8	Ground Handling Gear Pump, P/N BU0953B - Assembly .....	3-19
3-9	Ground Handling Gear Pump, P/N HP9902-41-10 .....	3-21
3-10	Work Aid - Packing Nut Tool Removal/Installation - Fabrication Instructions .....	3-23
3-11	Ground Handling Wheels - Adjustment Dimensions .....	3-25
4-1	Power Plant Installation - Right Side .....	4-2
4-2	Power Plant Installation - Left Side .....	4-2.2
4-3	Engine Vibration Test Equipment Cabling Tiedown .....	4-4
4-3.1	Deleted	
4-4	Engine Installation .....	4-7
4-5	Engine Mount Fittings (Trunnions) Installation .....	4-13
4-6	Damage Limits - Aft Engine Mount Fittings (Trunnions) and Bearings .....	4-16
4-7	Particle Separator and FOD Screen Installation (Prior to Incorporation of MWO 55-1520-236-50-12) .....	4-19
4-7.1	<b>E M</b> Centrisep Particle Separator Installation (After Incorporation of MWO 55-1520-236-50-12) .....	4-22.2
4-8	Particle Separator-Air Flow Diagram (Prior to Incorporation of MWO 55-1520-236-50-12) .....	4-23
4-8.1	<b>E M</b> Centrisep Particle Separator Air Flow Diagram (After Incorporation of MWO 55-1520-236-50-12) .....	4-24.1
4-9	Particle Separator and FOD Screen Assemblies (Prior to Incorporation of MWO 55-1520-236-50-12) .....	4-26
4-10	Inlet Vane Reinforcement Doubler - Fabrication .....	4-30
4-10.1	<b>E M</b> Centrisep Particle Separator Repair/Replacement (After Incorporation of MWO 55-1520-236-50-12) .....	4-30.1
4-11	FOD (Foreign Object Damage) Screen Installation .....	4-34
4-12	<b>P E</b> Exhaust System Components .....	4-37
4-13	<b>P E</b> Engine Tailpipe Repair .....	4-38
4-14	Engine Deck and Firewall Sealing .....	4-40
4-15	<b>P E</b> Exhaust System Components with IR Suppression Installation .....	4-41
4-15.1	Hot Metal Plus Plume Suppressor .....	4-44.10
4-15.2	Outer Body Half - Section .....	4-44.11
4-16	Repair Procedures - Infrared Suppression System .....	4-45
4-17	<b>M</b> Exhaust System Components with IR Suppression - Installation .....	4-47
4-17.1	<b>M</b> Suppressor Major Structural Elements .....	4-50
4-18	Engine Oil System Installation .....	4-50.1
4-18.1	ODDS Oil Separator and Oil Filter Installation (MWO 1-1520-236-50-30) .....	4-50.3
4-19	Engine Oil System Schematic .....	4-54.3
4-19.1	Oil Separator (Lubriclone) Assembly .....	4-54.4
4-19.2	Deleted	
4-19.3	Engine External Oil Filter .....	4-54.6
4-20	Oil Tank Installation .....	4-57

LIST OF ILLUSTRATIONS (CON'T)

NUMBER	TITLE	PAGE
4-21	Engine Oil Cooler Installation .....	4-60
4-22	Oil Cooler Cleaning Schematic .....	4-61
4-23	Engine Oil Cooler Turbine Fan .....	4-64
4-24	Oil Cooler Turbine Fan Assembly .....	4-66
4-25	Power Lever Control System Installation .....	4-70
4-26	Engine Idle Stop Installation .....	4-73
4-27	Droop Compensator Controls Installation .....	4-75
4-28	Rigging Procedures - Droop Compensator Controls .....	4-79
4-29	Engine Shipping Container .....	4-81
4-30	Ignition Unit .....	4-83
4-31	Aft Engine Trunnion Installation .....	4-84
4-32	Trunnion, Cambox, and Linear Actuator Installation .....	4-85
4-33	Power Turbine Tachometer Generator, Oil Pressure Transducer, Oil Pressure Switch, and Fuel Pressure Switch Installation .....	4-86

## LIST OF ILLUSTRATIONS (CONT)

NUMBER	TITLE	PAGE
4-34	Starter Generator and Gas Producer Tachometer Generator .....	4-87
4-35	Installation – Engine Torque Transducer Hose .....	4-89
4-36	Installation – Fuel Drain and Bleed Lines .....	4-91
4-37	Installation – Starter Fuel Filter and Oil Bypass Valve Hose .....	4-92
4-38	Installation – Bleed Air Tubing .....	4-93
4-39	Installation – Oil Hose .....	4-95
4-40	Installation – Heat Shield Tailpipe and Ejector .....	4-96
4-41	Electrical Cable Installation – Engine Left Side .....	4-97
4-42	Electrical Cable Installation – Engine Right Side .....	4-100
5-1	Main Rotor System .....	5-2
5-2	Main Rotor Installation .....	5-4
5-3	Main Rotor System Torque Values .....	5-6
5-4	Tool Application – Grip Lock Installation on Pitch Horn .....	5-7
5-4.1	Barrel Jack Installation .....	5-8
5-4.2	Barrel Jack Work Aid .....	5-8.1
5-5	Tool Application – Main Rotor Mast Nut Removal/Installation .....	5-8.2
5-6	Tool Application Alignment of Main Rotor Hub and Blade .....	5-9
5-7	Damage Limits – Cone Set .....	5-11
5-8	Pitch Link Assembly Adjustments .....	5-13
5-9	Pitch Link Assembly .....	5-14
5-10	Main Rotor Hub and Blade Assembly .....	5-16
5-11	Work Aid for Main Rotor Blade Bolt Removal Fabrication Instructions (AVIM) .....	5-17
5-12	Work Aid Application Main Rotor Blade Retaining Bolt Removal .....	5-18
5-13	B540 Main Rotor Blade .....	5-23
5-14	B540 Main Rotor Blade Authorized Patch Area (AVIM) .....	5-25
5-15	B540 Main Rotor Blade Trim Tab Installation .....	5-27
5-16	K747 Main Rotor Blade (Part Numbers K747-003-205, -209, -303) .....	5-30.1
5-16.1	K747 Main Rotor Blade (Part Numbers K747-003-309, -401, -403) .....	5-31
5-17	External Appearance Changes to K747-003-205/-309, -209/-401, and -303/-403 Blades Resulting from Improved Weight Retention Features .....	5-32
5-18	Internal Modification Incorporated in K747-003-205/-309, -209/-401, and -303/-403 Blades for Improved Weight Retention .....	5-33
5-19	Damage Limits – Root Fittings (K747 Blade) .....	5-36.2
5-19.1	Damage Limits – Root Fittings – Part Number K747-083-1 (K747 Blade) .....	5-37
5-20	Damage Limits – Drag Strut (P/N K747-072-1) (K747 Blade) .....	5-38
5-20.1	Damage Limits – Drag Strut – Part Number K747-082-1 (K747 Blade) .....	5-38.1
5-21	Inspection of K747-003-205/-309, -209/-401, -303/-403 Blades for Loss of Blade Weight Retention Integrity .....	5-39
5-22	Proximity Limits for Patches – K747 Main Rotor Blades .....	5-40
5-23	Balance Adjustment for Patches (K747 Blade) .....	5-43
5-24	Root Fitting Assembly (K747-205, -209, -303 Blades) .....	5-52
5-24.1	Root Fitting Assembly (-309, -401, -403 Blades) .....	5-52.1
5-24.2	Drag Strut Assembly (-309, -401, -403 Blades) .....	5-52.3
5-25	Application of Skin Patch (K747 Blade) .....	5-54
5-26	Curing Patch with Blade Repair Fixture (K747 Blade) .....	5-56
5-27	Installation of Plug Patch (K747 Blade) .....	5-60

**LIST OF ILLUSTRATIONS (CON'T)**

	TITLE	PAGE
5-28	Typical Double Plug Patch Repair (K747 Blade) .....	5-67
5-28.1	Application of Trailing Edge Doubler Patch (K747 Blade) .....	5-68
5-28.2	Spline Repair (K747 Blade) .....	5-71
5-28.3	Rebonding Delaminated Leading Edge Erosion Guard (K747 Blade) .....	5-72.1
5-28.4	Typical Repair of Fluorocarbon Erosion Guard Nicks and Cuts Using Kit, P/N 747-207 .....	5-72.3
5-28.5	Application of Leading Edge Erosion Guard Patch (K747 Blade) .....	5-72.5
5-28.6	Placement of Erosion Guard Replacement Part (Kit, P/N K747-206-1) Method for Determining Current Boot Material and Thickness (K747 Blade Series) .....	5-72.7
5-28.7	K747 Blade Uralite Repair .....	5-72.10
5-28.8	Application of Vacuum Bagging Materials and Placement of Erosion Guard .....	5-72.11
5-28.9	Repair Parts and Specimen Orientation (Kit, P/N 747-206) .....	5-72.15
5-28.10	Vacuum Bagging for Installation of Erosion Guard Repair Kit, P/N K747-206 .....	5-72.18
5-28.11	Improvised Mold for Casting a Small Section of Leading Edge Filler .....	5-72.21
5-28.12	Repair Parts Orientation Use for Removal and Installation of Stainless Steel Erosion Guard - K747-003-303/-403 and -303/-403 Field Modified Blades .....	5-72.23
5-28.13	Preparation of K747-003-303/-403 Blade for Application of Sealant .....	5-72.24
5-28.14	Application of Sealant to Stainless Steel Guard for K747-003-303/-403 Blade .....	5-72.26
5-28.15	Stainless Steel Erosion Guard Holding Fixture .....	5-72.27
5-28.16	Masking for Paint Touch-Up After Installation of Kit K747-206 .....	5-72.31
5-29	Main Rotor Hub Yoke Extension and Grip Assembly .....	5-72.35
5-30	Main Rotor Hub Yoke and Trunnion .....	5-74
5-31	Main Rotor Bearing Wear Patterns .....	5-77
5-32	Damage Limits - Main Rotor Hub Yoke Extension .....	5-78
5-33	Damage Limits - Main Rotor Hub Bolt Holes .....	5-79
5-34	Damage Limits - Main Rotor Hub Yoke .....	5-81
5-35	Damage Limits - Main Rotor Hub Grip .....	5-82
5-36	Damage Limits - Main Rotor Hub Strap Fitting .....	5-83
5-37	Damage Limits - Pitch Horn Bushing .....	5-85
5-38	Damage Limits - Main Rotor Hub Pitch Horn 209-010-109-5 (Prior to Accomplishment of MWO 55-1520-244-50-6) .....	5-86
5-38.1	Damage Limits - Main Rotor Hub Pitch Horn 209-010-109-109 (After Accomplishment of MWO 55-1520-244-50-6 and MWO 55-1520-244-50-9) .....	5-86.1
5-39	Damage Limits - Main Rotor Drag Brace .....	5-87
5-40	Damage Limits - Main Rotor Hub Trunnion .....	5-88
5-40.1	Damage Limits - Hub Moment Spring Plate .....	5-88.1
5-40.2	Damage Limits - Hub Moment Spring Strap .....	5-88.2
5-41	Damage Limits - Main Rotor Hub Elastomeric Bearing .....	5-89
5-42	Main Rotor Hub Yoke Chafing Pad Installation Dimensions .....	5-90
5-42.1	Main Rotor Hub Yoke Buffer Installation - Dimensions .....	5-90
5-43	Tool Application - Bearing Removal From Housing .....	5-90.2
5-44	Tool Application - Bearing Removal From Grip .....	5-92
5-45	Tool Application - Bearing and Seal Installation in Grip .....	5-93
5-46	Tool Application - Main Rotor Hub Trunnion Centering .....	5-96
5-47	Tool Application - Grip Spacing Adjustment .....	5-97
5-48	Main Rotor Hub Grip Dust Seal to Radius Ring Dimension .....	5-99
5-49	Rotor Balancing Kit P/N 7A050 .....	5-101
5-50	Tool Application - Main Rotor Hub Balancing .....	5-102
5-51	Main Rotor Controls Installation .....	5-104
5-52	Tool Application - Spline Plate Wear Measurement .....	5-107
5-52.1	Hub Moment Spring Support Assembly - Installation (MWO 55-1520-244-50-3 Incorporated) .....	5-108

## LIST OF ILLUSTRATIONS (CON'T)

	TITLE	PAGE
5-53	Collective Lever Trust Washer Wear Limits .....	5-108.1
5-53.1	Rod End Clevis Movement .....	5-108.4
5-53.2	Rod End Bearing .....	5-108.5
5-54	Damage Limits – Pitch Link Assembly (Prior to Accomplishment of MWO 55-1520-244-50-9) .....	5-109
5-54.1	Damage Limits – Pitch Link Assembly 209-010-520-103 (After Accomplishment of MWO 55-1520-244-50-9) .....	5-110.1
5-55	Damage Limits – Spline Plate .....	5-110.2
5-56	Damage Limits – Collective Lever .....	5-111
5-57	Damage Limits – Collective Lever Idle Link .....	5-112
5-58	Collective Lever Idle Link Assembly .....	5-113
5-59	Damage Limits – Swashplate Anti-Drive Link .....	5-114
5-60	Swashplate Anti-Drive Link .....	5-115
5-61	Damage Limits – Swashplate Anti-Drive Assembly Bellcrank .....	5-116
5-62	Damage Limits – Swashplate Anti-Drive Assembly Support .....	5-117
5-63	Swashplate Anti-Drive Assembly .....	5-118
5-63.1	Damage Limits – Hub Moment Spring Support Set, P/N 209-011-212-101 (MWO 55-1520-244-50-3 Incorporated) .....	5-120.2
5-63.2	Damage Limits – Hub Moment Spring .....	5-120.3
5-64	Scissors and Sleeve Assembly .....	5-121
5-65	Damage Limits – Hub, Sleeve, Scissors and Link .....	5-124
5-65.1	Installation of Shims .....	5-130.1
5-65.2	Collet Work Aid .....	5-130.1
5-66	Swashplate and Support Assembly .....	5-132
5-67	Damage Limits – Swashplate and Support Assembly .....	5-135
5-68	Tail Rotor Installation .....	5-139
5-69	Tail Rotor Hub and Blade Assembly .....	5-144
5-70	Tool Application – Tail Rotor Hub and Blade Assembly Balancing .....	5-146
5-71	Tail Rotor Hub Assembly .....	5-150
5-72	Damage Limits – Tail Rotor Hub Yoke .....	5-151
5-73	Damage Limits – Tail Rotor Hub Trunnion Set .....	5-152
5-74	Bearing Staking Tool P/N T101577 .....	5-153
5-75	Tool Application – Bearing Installation (Staking) in Tail Rotor Yoke .....	5-155
5-76	Tail Rotor Controls – Crosshead, Weights, Links and Control Tube .....	5-156
5-77	Damage Limits – Tail Rotor Control Crosshead .....	5-160
5-78	Damage Limits – Tail Rotor Control Counterweight Bellcrank .....	5-161
5-79	Damage Limits – Tail Rotor Controls Pitch Link .....	5-162
5-80	Damage Limits – Tail Rotor Control Counterweight Link .....	5-163
5-81	Damage Limits – Tail Rotor Control Counterweight Support .....	5-164
5-82	Damage Limits – Tail Rotor Control Tube .....	5-165
5-83	Damage Limits – Link Assembly .....	5-166
5-84	Damage Limits – Idler .....	5-167
5-85	Damage Limits – Lever .....	5-168





## LIST OF ILLUSTRATIONS (CON'T)

	TITLE	PAGE
5-86	Damage Limits - Tail Rotor Retention Nut .....	5-169
5-87	Tail Rotor Blade Pitch Horn Installation .....	5-171
5-88	Tail Rotor Blade Assembly .....	5-172
5-89	Tail Rotor Blade Station Diagram and Scratch -Type Damage Area Locations .....	5-173
5-90	Tail Rotor Blade - Area Authorized for Patch - Type Repair .....	5-174
5-91	Tail Rotor Blade Butt Area Repair .....	5-176
5-92	Damage Limits - Tail Rotor Blade Pitch Horn .....	5-178
5-93	Main Rotor Tracking Chart .....	5-182
5-94	Vertical Vibration Correction Chart .....	5-183
5-95	Vertical and Lateral Vibration Chart for K747 Rotor Blades .....	5-185
5-96	Lateral Vibration Correction Chart for B-540 Rotor Blades .....	5-187
5-97	Tracking Main Rotor .....	5-188
5-98	Tracking Main Rotor .....	5-189
5-99	Vibrex 4591 System Components and Carrying Case .....	5-191
5-100	A Main Rotor Balance Chart .....	5-194
5-101	Reading a Main Rotor Balance Chart .....	5-195
5-102	Reading a Main Rotor Balance Chart with an Incorrect "Clock Angle" .....	5-196
5-103	Reading the Tail - Rotor Charts .....	5-198
5-104	Magnetic Pickup and Double Interrupter Installation .....	5-200
5-105	Magnetic Pickup/Interrupter Installation .....	5-201
5-106	Magnetic Pickup Cable Installation .....	5-202
5-107	Balancer Installation .....	5-203
5-108	Lateral Accelerometer Installation .....	5-204

LIST OF ILLUSTRATIONS (CON'T)  
TITLE

	TITLE	PAGE
5-109	Vertical Accelerometer Installation .....	5-205
5-110	Deleted	
5-111	Tip Targets Installation .....	5-208
5-112	Reflective Target Installation .....	5-209
5-113	Reading the Main Rotor Chart .....	5-210
5-114	Reading the Main Rotor Tracking Chart .....	5-212
5-115	Accelerometer Cable Installation (Typical) .....	5-214
5-116	Tracking Tail Rotor .....	5-215
5-117	Balancing Tail Rotor .....	5-217
6-1	Drive Train (Typical) .....	6-4
6-2	Gearbox Oil Contamination – Description and Corrective Action .....	6-5
6-2.1	Typical Oil System Debris at 6X Magnification .....	6-6.3
6-2.1	Deleted	
6-3	Main Driveshaft Installation .....	6-8
6-4	Tool Application – Transmission Positioning Jacks P/N T101440 (T35) .....	6-10
6-5	Tool Application – Engine to Transmission Driveshaft Alignment P/N T101419 (T35) .....	6-11
6-6	Main Driveshaft Assembly .....	6-13
6-7	Inspection and Lubrication of Main Driveshaft .....	6-14.1
6-7.1	Main Driveshaft Internal Corrosion Area .....	6-17
6-8	Coupling Wear Criteria for Driveshaft .....	6-18
6-9	Damage Limits – Main Driveshaft Assembly .....	6-20
6-9.1	Main Driveshaft .....	6-20.1
6-9.2	Main Driveshaft Installation and Removal Tool .....	6-20.2
6-9.3	Work Aid Tool Installed on Main Driveshaft .....	6-20.2
6-9.4	Main Driveshaft Damage Limits .....	6-20.3
6-10	Transmission Quills .....	6-25
6-11	Transmission Installation .....	6-27
6-12	Transmission Buildup .....	6-29
6-13	<b>P</b> Transducer Bracket Installation .....	6-32
6-14	Damage Limits – Transmission .....	6-34
6-15	Transmission Shipping Covers, Caps, and Plugs .....	6-41
6-15.1	Lift Link Attaching Point .....	6-44.1
6-16	Main Input Quill Assembly .....	6-45
6-16.1	Transmission Input Quill Work Aid (Sheet 1 of 2) .....	6-46.1
6-16.2	Transmission Input Quill Work Aid (Sheet 2 of 2) .....	6-46.2
6-16.3	Input Drive Quill Wear Sleeve Replacement .....	6-46.3
6-17	Work Aid – Main Input Drive Quill Installation .....	6-47
6-18	Damage Limits – Tail Rotor Drive Quill .....	6-50
6-19	Tail Rotor Drive Quill Assembly .....	6-53
6-20	Hydraulic Pump and Tachometer Drive Quill Assembly .....	6-56
6-21	Fan Drive Quill Assembly .....	6-58
6-22	Work Aid – Quill Installation .....	6-59
6-23	<b>E M</b> Alternator Drive Quill Assembly .....	6-62
6-24	Main Rotor Mast Assembly .....	6-64
6-24.1	Inspection of Buffers and Plates .....	6-65
6-24.2	Workaid for Mast Buffer .....	6-66
6-25	Damage Limits – Main Rotor Mast Assembly .....	6-66.1
6-26	Deformation Limits – Main Rotor Mast .....	6-68
6-27	Damage Limits – Main Rotor Mast Bearing and Mast Bearing Retaining Plate .....	6-69
6-28	Transmission Top Case Dimension Check .....	6-73
6-29	Tail Rotor Driveshaft Installation .....	6-76
6-30	Tail Rotor Driveshaft Inspection Diagram .....	6-77
6-31	Tail Rotor Driveshaft Hanger Assembly .....	6-81

## LIST OF ILLUSTRATIONS (CON'T)

	TITLE	PAGE
6-32	Coupling Teeth Wear Patterns .....	6-82
6-33	Work Aid – Driveshaft Hanger Support Alignment .....	6-85
6-34	Intermediate Gearbox Installation .....	6-87
6-35	Intermediate Gearbox Quill, Seals, and Couplings (Typical) .....	6-88
6-35.1	Intermediate and Tail Rotor Gearbox Troubleshooting Chart .....	6-90.2
6-36	Damage Limits – Intermediate Gearbox .....	6-91
6-37	Oil Filler Cap Assembly .....	6-99
6-38	Tail Rotor Drive Gearbox Installation .....	6-103
6-39	Tail Rotor Drive Gearbox Assembly .....	6-105
6-40	Tail Rotor Drive Gearbox Input Quill .....	6-106
6-41	Damage Limits – Tail Rotor Drive Gearbox .....	6-108
6-42	Roller Bearing Wear Patterns .....	6-115
6-43	Tail Rotor Drive Gearbox Gear Patterns .....	6-116
6-44	Tool Application – Removal/Installation of Tail Rotor Drive Gearbox Input Quill Retainer Bolt .....	6-119
6-45	Tool Application – Removal/Installation of Tail Rotor Drive Gearbox Input Quill Retainer Nut .....	6-120
6-45.1	Driveshaft/Spherical Couplings .....	6-120.2
6-45.2	Coupling Inspection .....	6-120.2
6-46	Transmission Oil System Schematic (Typical) .....	6-126
6-47	Transmission Oil System Installation .....	6-127
6-48	Transmission Oil Pump .....	6-129
6-49	Transmission Oil Pump – Test Setup .....	6-131
6-50	Transmission Oil Cooler Installation .....	6-132
6-50.1	Oil Cooler Cleaning Schematic .....	6-132.2
6-51	Oil Cooler Automatic Emergency Bypass Valve Assembly .....	6-135
6-52	Damage Limits – Inlet Fitting .....	6-137
6-53	Damage Limits – Return Bypass Fitting .....	6-138
6-54	Damage Limits – Inlet Bypass Piston .....	6-139
6-55	Damage Limits – Piston .....	6-140



## LIST OF ILLUSTRATIONS (CON'T)

NUMBER	TITLE	PAGE
6-56	Damage Limits – Nozzles .....	6-141
6-57	Damage Limits – Sleeve .....	6-142
6-58	Damage Limits – Universal Fitting Bolt and Elbow .....	6-143
6-59	Damage Limits – Housing Assembly .....	6-144
6-60	Damage Limits – Plunger .....	6-146
6-61	Damage Limits – Elbow Fitting .....	6-147
6-62	Fittings – Repair .....	6-148
6-63	Nozzles – Repair .....	6-149
6-64	Plunger – Repair .....	6-149
6-65	Work Aid Application – Plunger and Piston .....	6-150
6-66	Oil Cooler Automatic Emergency Bypass Valve – Bench Test Schematic .....	6-151
6-67	Transmission External Oil Filter Installation (Typical) .....	6-153
6-67.1	Transmission External Oil Filter Installation (After Incorporation of MWO 1-1520-236-50-30) .....	6-154.3
6-67.2	Transmission External Oil Filter (After Incorporation of MWO 1-1520-236-50-30) .....	6-154.4
6-68	Transmission Oil Filter (Primary) Assembly .....	6-155
6-69	Transmission Oil Manifold Installation .....	6-158
6-70	Transmission Oil Pressure Relief Valve Assembly .....	6-159
7-1	<b>P</b> Hydraulic System .....	7-3
7-2	<b>P</b> Emergency (Electric Motor Driven) Hydraulic System .....	7-8
7-3	Dual Hydraulic Servo Cylinders Installation .....	7-9
7-4	Hydraulic Reservoirs .....	7-28
7-5	<b>P</b> Hydraulic Reservoir – Emergency System .....	7-29
7-6	Hydraulic Reservoir Assembly .....	7-31
7-7	Emergency Electric Motor Driven Hydraulic Pump Installation .....	7-37
7-8	Filter Element Installation .....	7-41
7-9	Non-Cleanable Filter Elements .....	7-42
7-10	<b>P</b> Accumulator and Lockout Valve Installation .....	7-43
7-11	Work Aid for Dual Hydraulic Cylinder Removal and Installation .....	7-46
7-12	Dual Hydraulic Cylinder .....	7-47
7-13	Tool Application - Cylinder Assembly Torque Fixture, Part Numbers T41000310 - and T100619-2 .....	7-49
7-14	Damage Limits for Hydraulic Cylinder Bearing Housing .....	7-52
7-15	Dual Hydraulic Cylinder Assembly (Typical) .....	7-53
7-16	Flight Control Hydraulic Cylinder and Servo Actuator Valve .....	7-55
7-17	<b>P</b> Dual Hydraulic Cylinder Valve Connections .....	7-59
7-18	Dual Hydraulic Cylinders to Swashplate and Collective Lever Installation .....	7-61
7-19	Dual Hydraulic Cylinder Servo Valve Installation .....	7-62
7-20	(SCAS) Servo Actuator Assembly .....	7-63
7-21	Tail Rotor Control Cylinder and Support Installation .....	7-66
7-22	Tail Rotor Control Cylinder and Support Assembly .....	7-67
7-22.1	Hydraulic Servocylinder, Part No. 1660 Series (Typical), Exploded View .....	7-68.4

## LIST OF ILLUSTRATIONS (CON'T)

NUMBER	TITLE	PAGE
7-22.2	Hydraulic Servocylinder, Part No. 1660 Series (Typical), Exploded View .....	7-68.6
7-23	Solenoid Valve P/N 204-076-504-3 Installation .....	7-73
7-24	Solenoid Valve P/N 204-076-504-3 FSCM 94641 P/N 1-U-1025-63 Assembly .....	7-75
7-25	Functional Test Setup for Solenoid Valve P/N 204-076-504-3 FSCM 94641 P/N 1-U-1025-63 .....	7-80
7-26	Flow Diagram for Solenoid Valve P/N 204-076-504-3 FSCM 94641 P/N 1-U-1025-63 .....	7-81
7-27	Pressure Drop Test Setup for Solenoid Valve P/N 204-076-504-3 FSCM 94641 P/N 1-U-1025-63 .....	7-81
7-28	Solenoid Valves (SCAS System) - Installation .....	7-84
7-29	<b>P</b> Solenoid Valve P/N 7U7464 Installation .....	7-92
7-30	<b>P</b> Solenoid Valve P/N 7U7464 Assembly .....	7-95
7-31	<b>P</b> Functional Test Setup for Solenoid Valve P/N 7U7464 .....	7-98
7-32	<b>P</b> Flow Diagram for Solenoid Valve P/N 7U7464 .....	7-98
7-33	<b>P</b> Pressure Drop Test Setup for Solenoid Valve P/N 7U7464 .....	7-99
7-34	Servo Actuator (Electrohydraulic) - Wing Pylon Armament .....	7-102
7-35	Work Aid for Wing Pylon Armament Servo Actuator Disassembly Assembly .....	7-104
7-36	Work Aid for Seal Installation on Wing Pylon Armament Servo Actuator .....	7-105
7-37	Sheet for Recording Test Data for Wing Pylon Armament Servo Actuator .....	7-107
7-38	Schematic Diagram Wing Pylon Armament Servo Actuator Connections for Bench Test .	7-108
7-38	Tool Application Wing Pylon Armament Servo Actuator Test Fixture .....	7-109
7-40	<b>E M</b> Hydraulic System .....	7-111
7-41	<b>E M</b> Emergency (Electric) Motor Driven Hydraulic System .....	7-117
7-42	<b>E M</b> Solenoid Valves P/N 204-076-504-3 Installation .....	7-144
7-43	<b>E M</b> Solenoid Valves (SCAS System) - Installation .....	7-149
8-1	<b>P E</b> Instrument System Equipment Location .....	8-2
8-2	Pitot - Static System .....	8-26.3
8-2.1	Connection for Pitot Leak Check (Typical) .....	8-26.4
8-2.2	Connection for Static Leak Check (Typical) .....	8-26.5
8-3	Test Circuit Setup for Fuel Tank Unit Capacitance and Resistance Tests .....	8-42
8-4	Test Circuit Setup for Fuel Quantity Indicator Bench Test .....	8-43
8-5	Circuit Arrangement and Adapter Cable for Fuel Quantity Adjustment Procedures on Installed System .....	8-44
8-5.1	Fuel Quantity Test Set P/N PSD60-1AF .....	8-44.4
8-5.2	Fuel Quantity "T" Cable P/N PSDAF-537 .....	8-44.5
8-5.3	Fuel Quantity Calibration Worksheet .....	8-44.6
8-6	Volt-Ammeter Test Set-up .....	8-49
9-1	<b>P</b> Simplified Electrical Bus Wiring Schematic .....	9-2
9-2	<b>E M</b> Simplified Electrical Bus Wiring Schematic .....	9-3
9-3	<b>P</b> Electrical Equipment Location Forward Section .....	9-4
9-4	<b>P</b> Electrical Equipment Location Pilot Section .....	9-6

## LIST OF ILLUSTRATIONS (CON'T)

NUMBER	TITLE	PAGE
9 - 5	<b>P</b> Electrical Equipment Location Gunner Section .....	9-8
9 - 6	<b>E</b> Electrical Equipment Location Aft Section .....	9-10
9 - 7	<b>E</b> Electrical Equipment Location Forward Section .....	9-13
9 - 8	<b>E</b> Electrical Equipment Location Pilot Section .....	9-13
9 - 9	<b>E</b> Electrical Equipment Location Gunner Section .....	9-18
9-10	<b>E</b> Electrical Equipment Location Aft Section .....	9-20
9-11	Environmental Connector Test Adapter .....	9-23
9-12	<b>P</b> Standby Inverter Adjustment .....	9-66
9-13	<b>P</b> Pilot Caution Panel .....	9-80.1
9-14	<b>E</b> Pilot Caution Panel .....	9-80.1
9-14.1	Deleted	
9-15	<b>M</b> Pilot Caution Panel .....	9-81
9-15.1	Deleted	
9 - 16	<b>P</b> Gunner Caution Panel .....	9-82.1
9 - 17	<b>E</b> <b>M</b> Gunner Caution Panel .....	9-82.1
9-17.1	Deleted	
9-17.2	Pilots Caution Panel Assembly .....	9-88.7
9-17.3	Pilots Caution Panel Subassembly .....	9-88.8
9-17.4	Housing Subassembly .....	9-88.11
9-17.5	Cover Assembly .....	9-88.11
9-17.6	Indicating Light Circuit Card .....	9-88.12
9-17.7	Contact Assembly .....	9-88.16
9-17.8	Polarizing Keys Location .....	9-88.17
9-17.9	Removal of Finish for Electrical Bonding .....	9-88.19





## LIST OF ILLUSTRATIONS (CON'T)

NUMBER	TITLE	PAGE
9-17.10	Position of Contacts in Latch Base.....	9-88.23
9-17.11	Gunners Caution Panel Schematic Diagram . . . . .	9-88.25
9-17.12	Gunners Caution Panel . . . . .	9-88.32
9-17.13	Gunners Caution Panel Wiring Connections . . . . .	9-88.35
9-18	Bench Test Set-Up for RPM Limits Warning Detector . . . . .	9-93
9-19	<b>P</b> Armament Equipment Location . . . . .	9-128
9-20	<b>P</b> TOW Missile Launcher Positions . . . . .	9-131
9-21	<b>P</b> Wing Stores Armament Test Panel . . . . .	9-139
9-22	<b>P</b> Wing Stores Armament Test Panel Schematic . . . . .	9-140
9-23	<b>E</b> Armament Equipment Location . . . . .	9-155
9-24	<b>E</b> TOW Missile Launcher Positions. . . . .	9-164
9-25	<b>E</b> DU Digital Display Test . . . . .	9-173
9-26	<b>E</b> LRU Fault Identification and Location Test . . . . .	9-173
9-27	<b>E</b> XM18 Minigun Circuitry Test Panel . . . . .	9-175
9-28	<b>E</b> Wing Stores Circuitry Test Panel. . . . .	9-180
9-29	<b>M</b> TOW Missile Launcher Positions . . . . .	9-195
9-30	<b>M</b> DU Digital Display Test . . . . .	9-204
9-31	<b>M</b> LRU Fault Identification and Location Test . . . . .	9-204
9-32	<b>M</b> XM18 Minigun Circuitry Test Panel. . . . .	9-206
9-33	<b>M</b> Wing Stores Circuitry Teat Panel . . . . .	9-211
10-1	Fuel Systems Schematic . . . . .	10-3
10-2	Fuel System . . . . .	10-4
10-3	Fuel Shutoff Valve.. . . . .	10-9
10-4	Fuel Boost Pump . . . . .	10-12.1
10-4.1	Fuel Boost Pump Cartridge . . . . .	10-12.2
10-4.2	Work Aid for Fuel Pump Cartridge Removal. . . . .	10-12.3
10-5	Collapsing Forward Fuel Cell . . . . .	10-22
10-6	Installed Forward Fuel Cell . . . . .	10-24
10-7	Collapsing Aft Fuel Cell . . . . .	10-26
11-1	Collective Controls . . . . .	11-4
11-2	Pilot Collective Stick Installation . . . . .	11-8
11-3	Pilot Collective Stick Assembly. . . . .	11-9
11-4	Bearing Installation - Pilot Throttle Grip . . . . .	11-14
11-6	Friction Lining Repair . . . . .	11-16
11-6	Throttle Lever Bearing Installation. . . . .	11-17
11-7	Collective Friction Tube Repairs. . . . .	11-18
11-8	Pilot Collective Stick Adjustments. . . . .	11-20
11-9	Gunner Collective Stick Installation . . . . .	11-22
11-10	Gunner Collective Stick-Assembly . . . . .	11-25
11-11	Gunner Collective Stick Adjustment. . . . .	11-27
11-12	Force-And-Aft Cyclic Controls . . . . .	11-30
11-13	Lateral Cyclic Controls . . . . .	11-32
11-14	Work Aid for Rigging Swashplat8e. . . . .	11-34

LIST OF ILLUSTRATIONS (CON'T)

NUMBER	TITLE	PAGE
11-15	Swashplate Rigging Dimensions . . . . .	11-35
11-16	Pilot Cyclic Stick Installation. . . . .	11-36
11-17	Pilot Cyclic Stick Assembly . . . . .	11-40
11-18	Collar and Bushing Installation. . . . .	11-42
11-19	Pilot Cyclic Stick Friction Adjustment . . . . .	11-44
11-20	Gunner Cyclic Stick Installation . . . . .	11-46
11-21	Gunner Cyclic Stick Assembly . . . . .	11-48
11-22	Fore-And-Aft Cyclic Jackshaft Installation, . . . . .	11-51
11-23	Force Gradient Assembly . . . . .	11-56.1
11-24	Tail Rotor Controls . . . . .	11-57
11-25	Tail Rotor Pedal Installation . . . . .	11-62
11-26	<b>P</b> Stability and Control Augmentation System (SCAS) . . . . .	11-70
11-27	<b>E</b> Stibility and Control Augmentation System (SCAS) . . . . .	11-71
11-27.1	SCAS Transducer Calibration . . . . .	11-74.2
11-28	Elevator Control System . . . . .	11-76
11-29	Elevator Installation . . . . .	11-79
11-30	Damage Limits - Fixed Length Flight Control Tubes and Links (Typical). . . . .	11-82
11-31	Control System Linkage Installation . . . . .	11-85
11-32	Damage Limits -Anti-Torque System . . . . .	11-95
11-33	Damage Limits - Elevator Control System . . . . .	11-102
11-34	Damage Limits -Collective Control System . . . . .	11-104
11-35	Damage Limits -Cyclic Control System . . . . .	11-110
11-36	Flight Control System Bearings . . . . .	11-118
11-37	Lateral Cyclic and Collective Controls Power Cylinder Support Installation . . . . .	11-119
11-38	Fore-And-Aft Cyclic Controls Power Cylinder Support Installation . . . . .	11-120
11-39	Damage Limits -Power Cylinder Supports . . . . .	11-121
12-1	Engine Fire Detection System . . . . .	12-3
12-2	Low G Warning System . . . . .	12-5
12-3	Low G Warning Assembly 8A10 . . . . .	12-9
12-4	Accelerometer 8A11 . . . . .	12-10
12-5	Low G Warning Light/Switch 8DS25 . . . . .	12-12
12-6	Converter 8M1 . . . . .	12-13
13-1	Environmental Control System . . . . .	13-3
13-2	Environmental Control Unit . . . . .	13-5
13-3	Environmental Control System Schematic... . . . .	13-7
13-4	Temperature Control Valve . . . . .	13-8
13-5	Temperature Control Valve Schematic . . . . .	13-9
13-6	ECU Cooling Turbine . . . . .	13-12
13-6.1	ECU Cooling Turbine Lubrication . . . . .	13-12.1
13-7	Pressure Regulator and Shutoff Valve. . . . .	13-14
13-8	Pressure Regulator and Shutoff Valve Schematic . . . . .	13-16
13-9	Blower Impeller Assembly . . . . .	13-18
13-10	Vent Air Control Valve-Installation . . . . .	13-21
13-11	Vent Air Control Valve . . . . .	13-22
13-12	Vent Air Control Valve Test Set-Up . . . . .	13-24
13-13	Rain Removal Manifold . . . . .	13-28
13-14	Rain Removal Thermal Switch-Installation . . . . .	13-30
13-15	Rain Removal Nozzle and Cleared Air Pattern . . . . .	13-31
13-16	Rain Removal Valve . . . . .	13-34
13-17	Limits Chart- Air Distribution Valve . . . . .	13-36
13-18	Tool Application -Teflon Lip Seal Installation . . . . .	13-38
16-1	<b>E M</b> Turret Installation . . . . .	16-4
16-2	Special Tools for Ejector Racks . . . . .	16-12

LIST OF ILLUSTRATIONS (CON'T)

NUMBER	TITLE	PAGE
16-3	Outboard Ejector Rack Installation . . . . .	16-21
16-4	Ejector Rack Alignment . . . . .	16-24
16-5	Outboard Ejector Rack Assembly . . . . .	16-27
16-6	Inboard Ejector Rack Installation . . . . .	16-32
16-6.1	Contact Profusion Inside Breech . . . . .	16-32.1
16-6.2	Wiring Harness Assembly . . . . .	16-32.2
16-7	Inboard Ejector Rack Assembly . . . . .	16-34
16-8	Wing Stores Pylon and Fairings . . . . .	16-35
17-1	Canopy Removal System . . . . .	17-2
17-2	Damage Limits -Linear Shaped Charge Assembly . . . . .	17-4
C-1	Inventory item List . . . . .	C-3
F-1	Wiring Identification Chart . . . . .	F-5
F-1.1	Symbols Chart . . . . .	F-6
F-1.2	<b>P</b> Altimeter Vibrator System Wiring Diagram . . . . .	F-45
F-2	<b>P</b> External Power System Wiring Diagram . . . . .	F-47
F-3	<b>P</b> Starter System Wiring Diagram. . . . .	F-49
F-4	<b>P</b> Ignition System Wiring Diagram . . . . .	F-50
F-5	<b>P</b> Anticollision and Position Lights System Wiring Diagram . . . . .	F-51
F-6	<b>P</b> Searchlight System Wiring Diagram . . . . .	F-52
F-7	<b>P</b> Engine De-Ice System Wiring Diagram . . . . .	F-53
F-8	<b>P</b> Fuel Valve and Oil Valve System Wiring Diagram . . . . .	F-54
F-9	<b>P</b> Fuel Boost System Wiring Diagram . . . . .	F-55
F-10	<b>P</b> Governor Control System Wiring System . . . . .	F-56
F-11	<b>P</b> Idle Stop System Wiring Diagram . . . . .	F-57
F-12	<b>P</b> Force Trim System Wiring Diagram . . . . .	F-58
F-13	<b>P</b> Environmental Control System Wiring Diagram . . . . .	F-59
F-14	<b>P</b> Pitot Heater System Wiring Diagram . . . . .	F-60
F-15	<b>P</b> TOW Blower Cooling System Wiring Diagram . . . . .	F-61
F-16	<b>P</b> Attitude Indicating System Wiring Diagram . . . . .	F-63
F-17	<b>P</b> FUEL Quantity Indicating System Wiring Diagram . . . . .	F-64
F-17.1	<b>P</b> Turn and Slip Indicating System Wiring Diagram . . . . .	F-65
F-18	<b>P</b> Radio Blower Cooling System Wiring Diagram . . . . .	F-65
F-18.1	<b>P</b> Armament Relay Location . . . . .	F-66
F-19	<b>E</b> AC Electrical Load Chart . . . . .	F-67
F-20	<b>E</b> Altimeter Vibrator System Wiring Diagram . . . . .	F-83
F-21	<b>E</b> External Power System Wiring Diagram . . . . .	F-85
F-22	<b>E</b> Starter System Wiring Diagram. . . . .	F-87
F-23	<b>E</b> Searchlight System Wiring Diagram . . . . .	F-89
F-24	<b>E</b> Engine De-Ice System Wiring Diagram . . . . .	F-90
F-25	<b>E</b> Fuel Valve and Engine Oil Valve System Wiring Diagram . . . . .	F-91
F-26	<b>E</b> Fuel Boost System Wiring Diagram . . . . .	F-92
F-27	<b>E</b> Governor Control System Wiring Diagram . . . . .	F-93
F-28	<b>E</b> Idle Stop System Wiring Diagram . . . . .	F-94
F-29	<b>E</b> Force Trim System Wiring Diagram . . . . .	F-95
F-30	<b>E</b> Environmental Control System Wiring Diagram . . . . .	F-97
F-31	<b>E</b> Pitot Heater System Wiring Diagram . . . . .	F-98
F-32	<b>E</b> TOW Blower Cooling System Wiring Diagram . . . . .	F-99
F-33	<b>E</b> Radio Blower Cooling System Wiring Diagram . . . . .	F-100
F-34	<b>E</b> Attitude Indicating System Wiring Diagram . . . . .	F-101
F-35	<b>E</b> Fuel Quantity indicating System Wiring Diagram . . . . .	F-102
F-36	<b>E</b> Tachometer Indicating System Wiring Diagram . . . . .	F-103
F-37	<b>E</b> Turn and Slip Indicating System Wiring Diagram . . . . .	F-105

LIST OF ILLUSTRATIONS (CON'T)

NUMBER	TITLE	PAGE
F-38	<b>E</b> Electrical Equipment Component Replacement Wiring Diagram . . . . .	F-106
F-38.1	<b>E</b> Armament Relay Location . . . . .	F-106.1
F-39	<b>M</b> AC Electrical Load Chart . . . . .	F-108
F-40	<b>M</b> DC Electrical Load Chart . . . . .	F-109
F-41	<b>M</b> Tachometer Indicating System. . . . .	F-110
F-42	<b>M</b> Pressure indicating Systems . . . . .	F-121
F-43	<b>M</b> Temperature Indicating Systems . . . . .	F-131
F-44	<b>M</b> Attitude Indicating System (Equipment Location) . . . . .	F-141
F-45	<b>M</b> Turn and Slip Indicating System . . . . .	F-147
F-46	<b>M</b> Fuel Quantity Indicating System . . . . .	F-151
F-47	<b>M</b> Altimeter Vibrator System . . . . .	F-160
F-48	<b>M</b> DC Generator Power System (Equipment Location) . . . . .	F-167
F-49	<b>M</b> Battery System (Equipment Location) . . . . .	F-177
F-50	<b>M</b> External Power Provisions . . . . .	F-184
F-5 1	<b>M</b> DC Power Distribution and Interconnect Logic (Equipment Location) . . . . .	F-189
F-52	<b>M</b> AC Power System (Equipment Location) . . . . .	F-197
F-53	<b>M</b> Starter System . . . . .	F-207
F-54	<b>M</b> Ignition System . . . . .	F-213
F-55	<b>M</b> Interior Lights System (Equipment Location) . . . . .	F-221
F-56	<b>M</b> Caution Lights System (Equipment Location) . . . . .	F-235
F-57	<b>M</b> RPM Limit Warning System (Equipment Location) . . . . .	F-259
F-58	<b>M</b> Position Lights System . . . . .	F-269
F-59	<b>M</b> Anticollision Light System . . . . .	F-276
F-60	<b>M</b> Searchlight System . . . . .	F-279
F-61	<b>M</b> Engine De-Ice System . . . . .	F-284
F-62	<b>M</b> Fuel Valve and Engine Oil Bypass Valve Systems . . . . .	F-292
F-63	<b>M</b> Fuel Boost System . . . . .	F-300
F-64	<b>M</b> Governor Control System . . . . .	F-307
F-65	<b>M</b> Idle Stop System . . . . .	F-316
F-66	<b>M</b> Force Trim System . . . . .	F-322
F-67	<b>M</b> Hydraulic Control System (Equipment Location) . . . . .	F-331
F-68	<b>M</b> Environmental Control System. . . . .	F-341
F-69	<b>M</b> Pitot HeaterSystem . . . . .	F-350
F-70	<b>M</b> TOW Blower Cooling System . . . . .	F-354
F-71	<b>M</b> Radio Blower Cooling System. . . . .	F-361
F-72	<b>M</b> Universal Turret Subsystem (Equipment Location) . . . . .	F-367
F-73	<b>M</b> TOW Missile Armament Subsystem (Equipment Location) . . . . .	F-383
F-74	<b>M</b> Fire Control System (Equipment Location) . . . . .	F-399
F-75	<b>M</b> Wing Stores Armament Subsystem (Equipment Location) . . . . .	F-413
F-76	<b>M</b> Electrical Equipment Component Replacement . . . . .	F-425
F-77	<b>M</b> Electrical Equipment Component Replacement (After MWO 55-1520-236-50-4) . . . . .	F-466
F-78	<b>MCN</b> C-NITE Subsystem (Equipment Location) . . . . .	F-469
F-79	<b>MCN</b> C-NITE Electrical Equipment Component Replacement . . . . .	F-471
F-80	<b>MCN</b> FLIR Subsystem Jumper Cable Assemblies . . . . .	F-472
FO-1	<b>P</b> Hydraulic System Schematic . . . . .	FO-1
FO-2	<b>E</b> <b>M</b> Hydraulic System Schematic . . . . .	FO-2
FO-3	Balancer and Strobex Description . . . . .	FO-3
FO-4	<b>P</b> AC Electrical Load Chart . . . . .	FO-4
FO-5	<b>P</b> AC Electrical Load Chart . . . . .	FO-5
FO-6	<b>P</b> AC Electrical Load Chart . . . . .	FO-6

LIST OF ILLUSTRATIONS (CON'T)

NUMBER	TITLE	PAGE
FO-7	<b>P</b> AC Electrical Load Chart . . . . .	FO-7
FO-8	<b>P</b> DC Electrical Load Chart . . . . .	FO-8
FO-9	<b>P</b> DC Electrical Load Chart . . . . .	FO-9
FO-10	<b>P</b> DC Electrical Load Chart . . . . .	FO-10
FO-11	<b>P</b> DC Electrical Load Chart . . . . .	FO-11
FO-12	<b>P</b> DC Electricd Load Chart . . . . .	FO-12
FO-13	<b>P</b> DC Electrical Load Chart . . . . .	FO-13
FO-14	<b>P</b> DC Electrical Load Chart . . . . .	FO-14
FO-15	<b>P</b> DC Electrical Load Chart . . . . .	FO-15
FO-16	<b>P</b> DC Electrical Load Chart . . . . .	FO-16
FO-17	<b>P</b> Battery System . . . . .	FO-17



LIST OF ILLUSTRATIONS (CON'T)

	TITLE	PAGE
FO-18	<b>P</b> Generator and DC Bus System .....	FO-18
FO-19	<b>P</b> AC Power Supply .....	FO-19
FO-19	<b>P</b> Interior Lights System .....	FO-20
FO-21	<b>P</b> Interior Lights System .....	FO-21
FO-21.1	<b>P</b> Interior Lights System .....	FO-21.1
FO-22	<b>P</b> Interior Lights System .....	FO-22
FO-22.1	<b>P</b> Interior Lights System .....	FO-22.1
FO-23	<b>P</b> Caution Lights System .....	FO-23
FO-24	<b>P</b> Caution Lights System .....	FO-24
FO-25t	<b>P</b> RPM Limit Warning System .....	FO-25
FO-26	<b>P</b> Hydraulic Control System .....	FO-26
FO-27	<b>P</b> Armament Turret System .....	FO-27
FO-28	<b>P</b> Armament Turret System .....	FO-28
FO-29	<b>P</b> Armament Turret System .....	FO-29
FO-30	<b>P</b> Armament Wing Stores System .....	FO-30
FO-31	<b>P</b> Armament Wing Stores System .....	FO-31
FO-32	<b>P</b> Armament Wing Stores System .....	FO-32
FO-33	<b>P</b> Armament TOW Missile Wiring Diagram .....	FO-33
FO-34	<b>P</b> Armament TOW Missile Wiring Diagram .....	FO-34
FO-35	<b>P</b> Armament TOW Missile Wiring Diagram .....	FO-35
FO-36	<b>P</b> Armament TOW Missile Wiring Diagram .....	FO-36
FO-37	<b>P</b> Pressure Indicating System .....	FO-37
FO-38	<b>P</b> Tachometer Indicating Systems .....	FO-38
FO-39	<b>P</b> Temperature Indicating Systems .....	FO-39
FO-40	<b>P</b> RPM Limit Warning Test Set Schematic .....	FO-40
FO-41	<b>E</b> AC Electrical Load Chart .....	FO-41
FO-42	<b>E</b> DC Electrical Load Chart .....	FO-42
FO-43	<b>E</b> DC Electrical Load Chart .....	FO-43
FO-44	<b>E</b> Battery System .....	FO-44
FO-45	<b>E</b> DC Generator Power System .....	FO-45
FO-46	<b>E</b> DC Power Distribution and Interconnect Logic .....	FO-46
FO-47	<b>E</b> DC Power Distribution and Interconnect Logic .....	FO-47
FO-48	<b>E</b> AC Power System .....	FO-48
FO-49	<b>E</b> Ignition System .....	FO-49

LIST OF ILLUSTRATIONS (CON'T)

	TITLE	PAGE
FO-50	<b>E</b> Interior Lights System .....	FO-50
FO-50.1	<b>E</b> Interior Lights System .....	FO-50.1
FO-51	<b>E</b> Interior Lights System .....	FO-51
FO-51.1	<b>E</b> Interior Lights System .....	FO-51.1
FO-52	<b>E</b> Interior Lights System .....	FO-52
FO-53	<b>E</b> Caution Lights System .....	FO-53
FO-54	<b>E</b> Caution Lights System .....	FO-54
FO-54.1	<b>E</b> Caution Lights System (After Incorporation of MWO 1-1520-236-50-30) .....	FO-54.1
FO-54.2	<b>E</b> Caution Lights System (After Incorporation of MWO 1-1520-236-50-30) .....	FO-54.2
FO-54.3	<b>E</b> Caution Lights System (After Incorporation of MWO 1-1520-236-50-30) .....	FO-54.3
FO-54.4	<b>E</b> Caution Lights System (After Incorporation of MWO 1-1520-236-50-30) .....	FO-54.4
FO-55	<b>E</b> RPM Limit Warning System .....	FO-55
FO-56	<b>E</b> Anticollision and Position Lights System .....	FO-56
FO-57	<b>E</b> Hydraulic Control System .....	FO-57
FO-58	<b>E</b> Turret System .....	FO-58
FO-59	<b>E</b> Turret System .....	FO-59
FO-60	<b>E</b> Turret System .....	FO-60
FO-61	<b>E</b> Turret System .....	FO-61
FO-62	<b>E</b> Turret System .....	FO-62
FO-63	<b>E</b> Turret System .....	FO-63
FO-64	<b>E</b> Turret System .....	FO-64
FO-65	<b>E</b> Wing Stores System .....	FO-65
FO-66	<b>E</b> Wing Stores System .....	FO-66
FO-67	<b>E</b> Wing Stores System .....	FO-67
FO-68	<b>E</b> TOW Missile System .....	FO-68
FO-69	<b>E</b> TOW Missile System .....	FO-69
FO-70	<b>E</b> TOW Missile System .....	FO-70
FO-71	<b>E</b> TOW Missile System .....	FO-71
FO-72	<b>E</b> TOW Missile System .....	FO-72
FO-73	<b>E</b> TOW Missile System .....	FO-73
FO-74	<b>E</b> TOW Missile System .....	FO-74
FO-75	<b>E</b> TOW Missile System .....	FO-75
FO-76	<b>E</b> TOW Missile System .....	FO-76
FO-77	<b>E</b> TOW Missile System .....	FO-77



LIST OF ILLUSTRATIONS (CON'T)

	TITLE	PAGE
FO-78	<b>E</b> Pressure Indicating System .....	FO-78
FO-79	<b>E</b> Temperature Indicating System .....	FO-79
FO-80	<b>E</b> Electrical Equipment Component Replacement .....	FO-80
FO-81	<b>E</b> Electrical Equipment Component Replacement .....	FO-81
FO-81.1	<b>E</b> Electrical Equipment Component Replacement .....	FO-81.1
FO-82	<b>E</b> Electrical Equipment Component Replacement .....	FO-82
FO-83	<b>E</b> Electrical Equipment Component Replacement .....	FO-83
FO-84	<b>E</b> Electrical Equipment Component Replacement .....	FO-84
FO-85	<b>E</b> Electrical Equipment Component Replacement .....	FO-85
FO-86	<b>E</b> Electrical Equipment Component Replacement .....	FO-86
FO-87	<b>E</b> Electrical Equipment Component Replacement .....	FO-87
FO-88	<b>E</b> Electrical Equipment Component Replacement .....	FO-88
FO-89	<b>E</b> Electrical Equipment Component Replacement .....	FO-89
FO-90	<b>E</b> Electrical Equipment Component Replacement .....	FO-90
FO-91	<b>M</b> Pressure Indicating System .....	FO-91
FO-92	<b>M</b> Temperature Indicating Systems .....	FO-92
FO-93	<b>M</b> Attitude Indicating System .....	FO-93
FO-94	<b>M</b> DC Generator Power System .....	FO-94
FO-95	<b>M</b> Battery System .....	FO-95
FO-96	<b>M</b> DC Power Distribution and Interconnect Logic .....	FO-96
FO-97	<b>M</b> DC Power Distribution and Interconnect Logic .....	FO-97
FO-98	<b>M</b> AC Power System .....	FO-98
FO-99	<b>M</b> Ignition System .....	FO-99
FO-100	<b>M</b> Interior Lights System .....	FO-100
FO-100.1	<b>M</b> Interior Lights System .....	FO-100.1
FO-101	<b>M</b> Interior Lights System .....	FO-101
FO-101.1	<b>M</b> Interior Lights System .....	FO-101.1
FO-102	<b>M</b> Interior Lights System .....	FO-102
FO-102.1	<b>M</b> Interior Lights System .....	FO-102.1
FO-103	<b>M</b> Interior Lights System .....	FO-103
FO-104	<b>M</b> Caution Lights System .....	FO-104
FO-105	<b>M</b> Caution Lights System .....	FO-105
FO-106	<b>M</b> RPM Limit Warning System .....	FO-106
FO-107	<b>M</b> RPM Limit Warning Test Set Schematic .....	FO-107
FO-108	<b>M</b> Hydraulic Control System .....	FO-108
FO-109	<b>M</b> Universal Turret Subsystem .....	FO-109
FO-110	<b>M</b> Universal Turret Subsystem .....	FO-110

LIST OF ILLUSTRATIONS (CON'T)

	TITLE	PAGE
FO-111	<b>M</b> Universal Turret Subsystem .....	FO-111
FO-112	<b>M</b> Universal Turret Subsystem .....	FO-112
FO-113	<b>M</b> Universal Turret Subsystem .....	FO-113
FO-114	<b>M</b> Universal Turret Subsystem .....	FO-114
FO-115	<b>M</b> Universal Turret Subsystem .....	FO-115
FO-116	<b>M</b> Universal Turret Subsystem .....	FO-116
FO-117	<b>M</b> Universal Turret Subsystem .....	FO-117
FO-118	<b>M</b> Universal Turret Subsystem .....	FO-118
FO-119	<b>M</b> TOW Missile Armament Subsystem .....	FO-119
FO-120	<b>M</b> TOW Missile Armament Subsystem .....	FO-120
FO-121	<b>M</b> TOW Missile Armament Subsystem .....	FO-121
FO-122	<b>M</b> TOW Missile Armament Subsystem .....	FO-122
FO-123	<b>M</b> TOW Missile Armament Subsystem .....	FO-123
FO-124	<b>M</b> TOW Missile Armament Subsystem .....	FO-124
FO-125	<b>M</b> TOW Missile Armament Subsystem .....	FO-125
FO-126	<b>M</b> TOW Missile Armament Subsystem .....	FO-126
FO-127	<b>M</b> TOW Missile Armament Subsystem .....	FO-127
FO-128	<b>M</b> TOW Missile Armament Subsystem .....	FO-128
FO-129	<b>M</b> TOW Missile Armament Subsystem .....	FO-129
FO-130	<b>M</b> Fire Control System .....	FO-130
FO-131	<b>M</b> Fire Control System .....	FO-131
FO-132	<b>M</b> Fire Control System .....	FO-132
FO-133	<b>M</b> Fire Control System .....	FO-133
FO-134	<b>M</b> Wing Stores Armament Subsystem .....	FO-134
FO-135	<b>M</b> Wing Stores Armament Subsystem .....	FO-135
FO-136	<b>M</b> Wing Stores Armament Subsystem .....	FO-136
FO-137	<b>M</b> Electrical Equipment Component Replacement .....	FO-137
FO-138	<b>M</b> Electrical Equipment Component Replacement .....	FO-138
FO-139	<b>M</b> Electrical Equipment Component Replacement .....	FO-139
FO-140	<b>M</b> Electrical Equipment Component Replacement .....	FO-140
FO-141	<b>M</b> Electrical Equipment Component Replacement .....	FO-141
FO-142	<b>M</b> Electrical Equipment Component Replacement .....	FO-142
FO-143	<b>M</b> <b>C</b> <b>N</b> TOW Missile Armament Subsystem .....	FO-143
FO-144	<b>M</b> <b>C</b> <b>N</b> Fire Control System .....	FO-199
FO-145	<b>E</b> <b>M</b> Low G Warning System .....	FO-211
FO-146	<b>M</b> AIM-1/EXL Laser Gunsight System .....	FO-213
FO-147	<b>M</b> GPS Trimpack System .....	FO-215

## LIST OF TABLES

NUMBER	TITLE	PAGE
1-1	Engine Fuel Specifications .....	1-3
1-2	Approved Fuels .....	1-4
1-3	Consumable Maintenance Supplies and Materials .....	1-10.1
1-4	Special Tools and Test Equipment .....	1-19
1-5	Support Equipment .....	1-24.1
1-6	Root Mean Square/Abrasive Chart Equivalency .....	1-24.1
1-7	Deleted	
1-8	Deleted	
1-9	Deleted	
1-10	Deleted	
1-11	Adhesive Mix Ratio, Pot Life, and Cure Cycles .....	1-24.2
1-11.1	Mooring Hardware Chart .....	1-54.1
1-12	Flight Safety Critical Aircraft Parts .....	1-89
2-1	Main Beam Panels (Structural) .....	2-13
2-2	Structural Repair Materials .....	2-17
2-3	Forward Fuselage - Classification of Damage .....	2-26
2-4	Tailboom - Classification of Damage .....	2-69
2-5	Wing - Classification of Damage .....	2-248
4-1	Repair Methods - IR Suppression System (AVIM) .....	4-43
4-1.1	IR Suppressor Damage and Repair Limits (Non Structural Area) .....	4-44.4
4-1.2	IR Suppressor Damage and Repair Limits (Major Structural Elements Only) .....	4-44.8
4-2	Troubleshooting Engine Oil System .....	4-51
4-2.1	Oil Debris Classification Chart .....	4-54.5
4-3	Dimension Tolerance - Turbine Fan .....	4-67
5-1	Difference Between Models .....	5-34
5-1.1	Classification of Damage - K747 Main Rotor Blades .....	5-45
5-1.2	Classification of Damage - K747 Main Rotor Blades .....	5-49
5-2	Plug Patch Data .....	5-58
5-3	Troubleshooting - Tail Rotor System .....	5-140
5-4	Troubleshooting the VIBREX4591 System with the VIBREX Tester, Model 11 .....	5-218
6-1	Troubleshooting - Drive Train System .....	6-1
6-1.1	Oil Debris Classification Chart (Aircraft without ODDS) .....	6-6.2
6-1.2	Oil Debris Classification Chart (Aircraft with ODDS) .....	6-6.4
6-2	Gearbox Oil Debris Classification .....	6-90.1
6-3	Troubleshooting - Transmission Oil System .....	6-122
7-1	Maximum Allowable Leakage for Hydraulic System .....	7-11
7-2	<b>P</b> Emergency Hydraulic System Operational Switching Sequence .....	7-15
7-3	<b>P</b> Troubleshooting of Hydraulic System .....	7-20
7-4	Torque Values for Fluid Connections .....	7-34
7-4.1	Inspection Criteria .....	7-68.3
7-4.2	Troubleshooting Chart .....	7-68.6
7-4.3	Leading Particulars (T/R Control Cylinder) .....	7-68.7
7-5	Leading Particulars for Solenoid Valve P/N 204-076-504-3 FSCM 94641 (1-U-1025-63) .....	7-71

LIST OF TABLES (CON'T)

NUMBER	TITLE	PAGE
7-6	Non-Destructive Test Requirements for Solenoid Valve P/N 204-076-504-3 FSCM 94641 P/N 1-U-1025-63 (AVIM) .....	7-76
7-7	Diametrical Clearance Requirements for Solenoid Valve P/N 204-076-504-3 FSCM 94641 P/N 1-U-1025-63 (AVIM) .....	7-77
7-8	Troubleshooting During Testing Solenoid Valve P/N 204-076-504-3 FSCM 94641 P/N 1-U-1025-63 (AVIM) .....	7-79
7-9	<b>P</b> Non-Destructive Test Requirements for Solenoid Valve P/N 7U7464 (AVIM) .....	7-84
7-10	<b>P</b> Diametrical Clearance Requirements for Solenoid Valve P/N 7U7464 (AVIM) .....	7-95
7-11	Troubleshooting During Testing of Solenoid Valve P/N 7U7464 (AVIM) .....	7-97
7-12	<b>E M</b> Emergency Hydraulic System Operational Switching Sequence .....	7-122
7-13	<b>E M</b> Troubleshooting Hydraulic System .....	7-125
7-14	Leading Particulars for Solenoid Valve P/N 204-076-504-3 FSCM 94641 P/N 1-U-1025-63 .....	7-142
8-1	Troubleshooting - Tachometer Indicating System .....	8-8
8-2	Troubleshooting - Engine and Transmissiodn Oil Temperature and Pressure indicating System .....	8-14
8-3	Troubleshooting - Turbine Gas Temperature Indicating System .....	8-20
8-4	Troubleshooting - Torque Pressure Indicating System .....	8-22
8-4.1	Tolerance - ( $\pm$ Knots) .....	8-26
8-4.2	Vertical Speed Tolerance Test Scale Accuracy .....	8-26.1
8-4.3	Vertical Speed Tolerance Test Scale Accuracy .....	8-26.1
8-5	Troubleshooting - Airspeed Indicators .....	8-29
8-6	Troubleshooting - Altimeters .....	8-30
8-7	Troubleshooting - Attitude Indicators .....	8-32
8-8	Troubleshooting - Vertical Speed Indicators .....	8-34
8-9	Troubleshooting - Free Air Temperature Gage .....	8-38
8-10	Troubleshooting - Fuel Quantity Indicating System .....	8-39
8-11	Fuel Tank Table of Limits .....	8-43
8-12	Troubleshooting - Voltmeter/Ammeter .....	8-48
8-13	<b>P E</b> Troubleshooting - Pilots Steering Indicator (PSI) .....	8-51
9-1	Troubleshooting - Battery System .....	9-29
9-2	Troubleshooting - External Power System .....	9-34
9-3	<b>P</b> Troubleshooting - Generator and DC Bus System .....	9-37
9-4	<b>P M</b> Troubleshooting - DC Generator Power System .....	9-41
9-4.1	Voltage Regulator Adjustment Settings .....	9-44.2
9-5	<b>P M</b> Troubleshooting - TRU Power System .....	9-46
9-6	<b>P M</b> DC Power Distribution and Interconnect Logic Chart .....	9-48
9-7	<b>P M</b> Troubleshooting - DC Power Distribution and Interconnect Logic .....	9-50
9-8	<b>P</b> Troubleshooting - Inverter System .....	9-58
9-9	<b>P M</b> Troubleshooting - AC Power System .....	9-62
9-10	Troubleshooting - Starting System .....	9-74

## LIST OF TABLES (CON'T)

NUMBER	TITLE	PAGE
9-11	Troubleshooting – Ignition System .....	9-75
9-12	Troubleshooting – Cockpit Lights .....	9-77
9-12.1	Dimmer Control Input/Output Voltages .....	9-78.1
9-13	Troubleshooting – Console, Engine, Flight, and Tactical Instrument Lights .....	9-79
9-14	Pilots Caution Panel Lights .....	9-83
9-15	Gunners Caution Panel Lights .....	9-83
9-15.1	Troubleshooting Pilots Caution Panel .....	9-88.2
9-15.2	Pilots Caution Panel Wiring Chart .....	9-88.21
9-15.3	Gunners Caution Panel Fault Inputs .....	9-88.27
9-15.4	Troubleshooting – Gunners Caution Panel .....	9-88.28
9-15.5	Gunners Caution Panel Wiring Chart .....	9-88.36
9-16	Troubleshooting – RPM Limit Warning System .....	9-91
9-16.1	Troubleshooting – Skid Landing Light System .....	9-94.1
9-16.2	Troubleshooting – ODDS .....	9-94.3
9-17	Troubleshooting – Position Lights System .....	9-95
9-18	Troubleshooting – Anticollision Light .....	9-98
9-19	Troubleshooting – Searchlight System .....	9-100
9-20	Troubleshooting – Transmission Oil Level Light .....	9-102
9-21	Troubleshooting – Engine De-Icing Circuitry .....	9-103
9-22	Troubleshooting – Engine Oil Bypass valve Circuitry .....	9-105
9-23	Troubleshooting – Fuel Valve Circuitry .....	9-106
9-24	Troubleshooting – Fuel Boost Pumps Circuitry .....	9-107
9-25	Troubleshooting – Governor Control Circuitry .....	9-108
9-26	Troubleshooting – Idle Stop Solenoid System Circuitry .....	9-110
9-26.1	<b>E M</b> Troubleshooting Centrisep Particle Separator Circuitry (After Incorporation of MWO 55-1520-236-50-12). .....	9-110.1
9-27	Troubleshooting – Force Trim System Circuitry .....	9-111
9-28	Troubleshooting – Hydraulic Control System Circuitry .....	9-113
9-29	Troubleshooting – Environmental Control System Circuitry .....	9-115
9-30	Troubleshooting – Pitot Heating System Circuitry .....	9-117
9-31	Troubleshooting – TOW Blower Cooling System .....	9-118
9-32	Troubleshooting – Radio Blower Cooling System .....	9-121
9-32.1	<b>P</b> Relay Matrix, Pilot in Control Mode .....	9-122.1
9-32.2	<b>P</b> Relay Matrix, Pilot in Fixed Forward Mode .....	9-122.3
8-32.3	<b>P</b> Relay Matrix, Gunner in Control Mode – HSS Controlling Turret .....	9-122.5
9-32.4	<b>P</b> Relay Matrix, Gunner in Control Mode – TSU Controlling Turret .....	9-122-7
9-32.5	<b>P</b> Relay Matrix, Gunner Controlling TOW and Pilot Controlling Turret and Wing Stores Mode .....	9-122.9
9-32.6	<b>P</b> Relay Matrix, TSU Acquisition of Target with Gunner or Pilot HSS Mode .....	9-122.11
9-32.7	<b>P</b> Relay Matrix, Pilot Override Mode .....	9-122.13
9-32.8	<b>P</b> Relay Matrix, Gunner Jettison Mode .....	9-122.15

## LIST OF TABLES (CON'T)

NUMBER	TITLE	PAGE
9-32.9	<b>P</b> Relay Matrix, Pilot Jettison Mode .....	9-122.16
9-33	<b>P</b> Wing Stores Jettison Checklist Chart .....	9-143
9-34	<b>P</b> Troubleshooting - Rocket Launcher Circuitry .....	9-145
9-35	<b>P</b> Troubleshooting - XM-18 Minigun Circuitry .....	9-150
9-36	<b>P</b> Troubleshooting - Wing Stores Jettison Circuitry .....	9-152
9-36.1	<b>E</b> Relay Matrix, Gunner in Control Mode - HSS Controlling Turret .....	9-156.1
9-36.2	<b>E</b> Relay Matrix, Gunner in Control Mode - TSU Controlling Turret .....	9-156.3
9-36.3	<b>E</b> Relay Matrix, Gunner Controlling TOW and Pilot Controlling Turret and Wing Stores Mode .....	9-156.5
9-36.4	<b>E</b> Relay Matrix, Pilot in Control Mode .....	9-156.7
9-36.5	<b>E</b> Relay Matrix, Pilot Override Mode .....	9-156.9
9-36.6	<b>E</b> Relay Matrix, TSU Acquisition of Target with Gunner or Pilot HSS Mode .....	9-156.11
9-36.7	<b>E</b> Relay Matrix, Gunner Jettison Mode .....	9-156.13
9-36.8	<b>E</b> Relay Matrix, Pilot Jettison Mode .....	9-156.14
9-37	<b>E</b> XM-18 Minigun Checkout Chart .....	9-176
9-38	<b>E</b> Troubleshooting - XM-18 Minigun Circuitry .....	9-177
9-39	<b>E</b> Wing Stores Jettison Checkout Chart .....	9-181
9-40	<b>E</b> Troubleshooting - Wing Stores Jettison Circuitry .....	9-183
9-41	<b>M</b> XM-18 Minigun Checkout Chart .....	9-207
9-42	<b>M</b> Troubleshooting - XM-18 Minigun Circuitry .....	9-208
9-43	<b>M</b> Wing Stores Jettison Checkout Chart .....	9-212
9-44	<b>M</b> Troubleshooting - Wing Stores Jettison Circuitry .....	9-214
10-1	Troubleshooting - Fuel System .....	10-1
11-1	Troubleshooting - Flight Control System .....	11-1
12-1	Troubleshooting - Engine Fire Detection System .....	12-1
12-2	Troubleshooting - Low G Warning System .....	12-6
13-1	Troubleshooting - ECU .....	13-1
13-2	Troubleshooting - Rain Removal Valve .....	13-32
16-1	<b>P</b> Troubleshooting Ejector Racks .....	16-13
16-2	<b>E</b> <b>M</b> Troubleshooting Ejector Racks .....	16-16
16-3	<b>M</b> Troubleshooting - AIM-1/EXL Laser Gunsight Subsystem .....	16-39
F-1	<b>P</b> Equipment List (Electrical) .....	F-9
F-2	<b>P</b> Equipment List (Armament) .....	F-15
F-3	<b>E</b> Equipment List (Electrical) .....	F-19
F-4	<b>E</b> Equipment List (Armament) .....	F-26
F-5	<b>M</b> Equipment List (Electrical) .....	F-32
F-6	<b>M</b> Equipment List (Armament) .....	F-39

By Order of the Secretary of the Army:

Official:

**J. C. PENNINGTON**  
*Major General, United States Army*  
*The Adjutant General*

**E. C. MEYER**  
*General, United States Army*  
*Chief of Staff*

DISTRIBUTION:

To be distributed in accordance with DA Form 12-31, Organizational Maintenance requirements for AH-1S (PROD) aircraft.





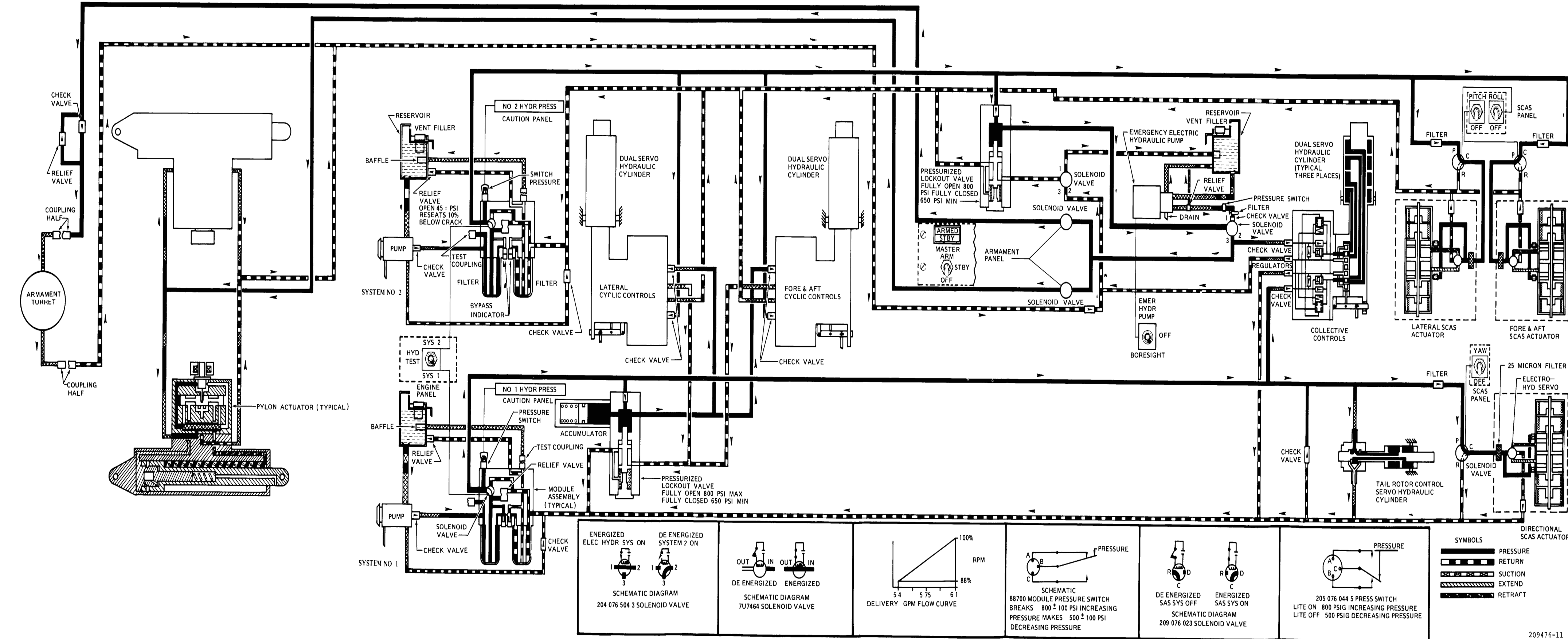

FO 1 Hydraulic System Schematic

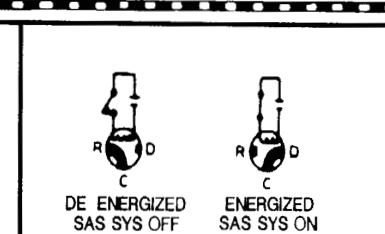
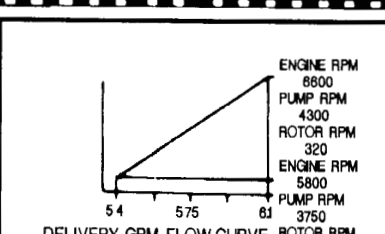
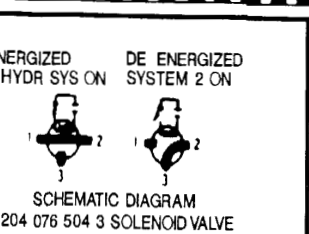
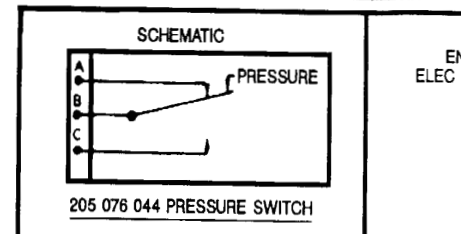
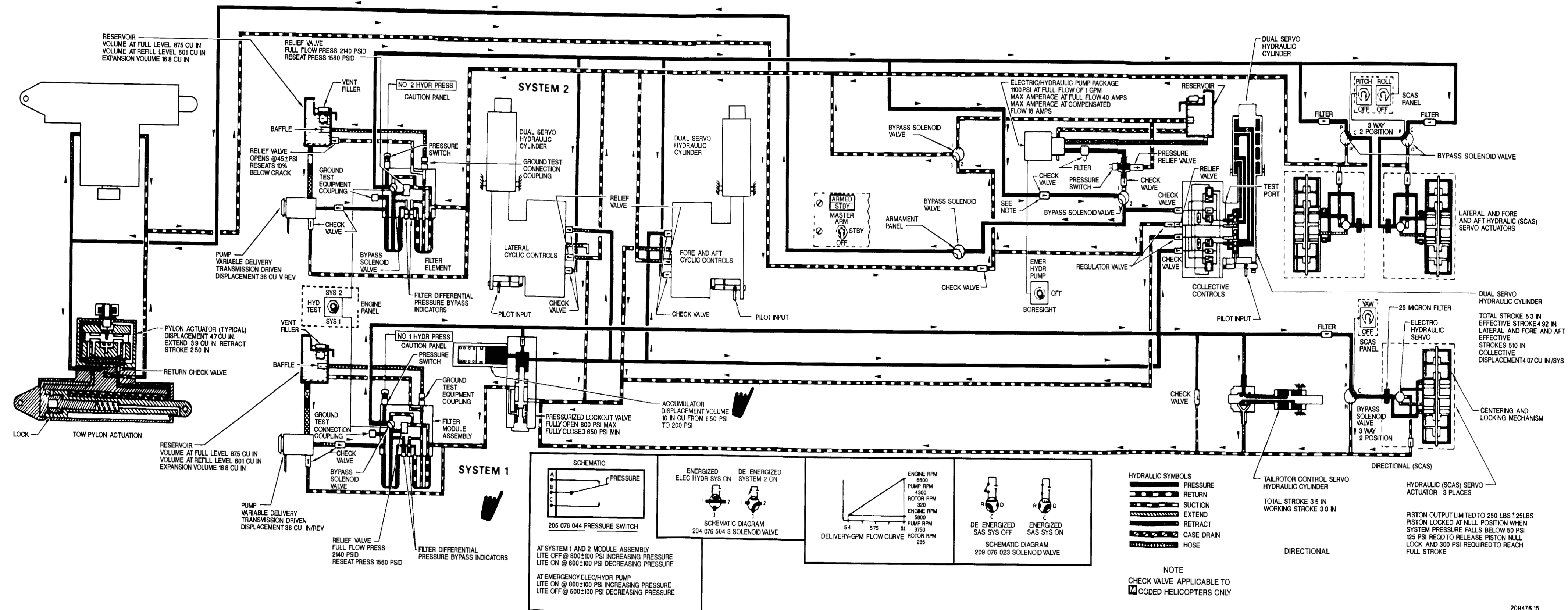

- HYDRAULIC SYMBOLS**
- PRESSURE
  - RETURN
  - SUCTION
  - EXTEND
  - RETRACT
  - CASE DRAIN
  - HOSE

**NOTE**  
CHECK VALVE APPLICABLE TO  
CODED HELICOPTERS ONLY

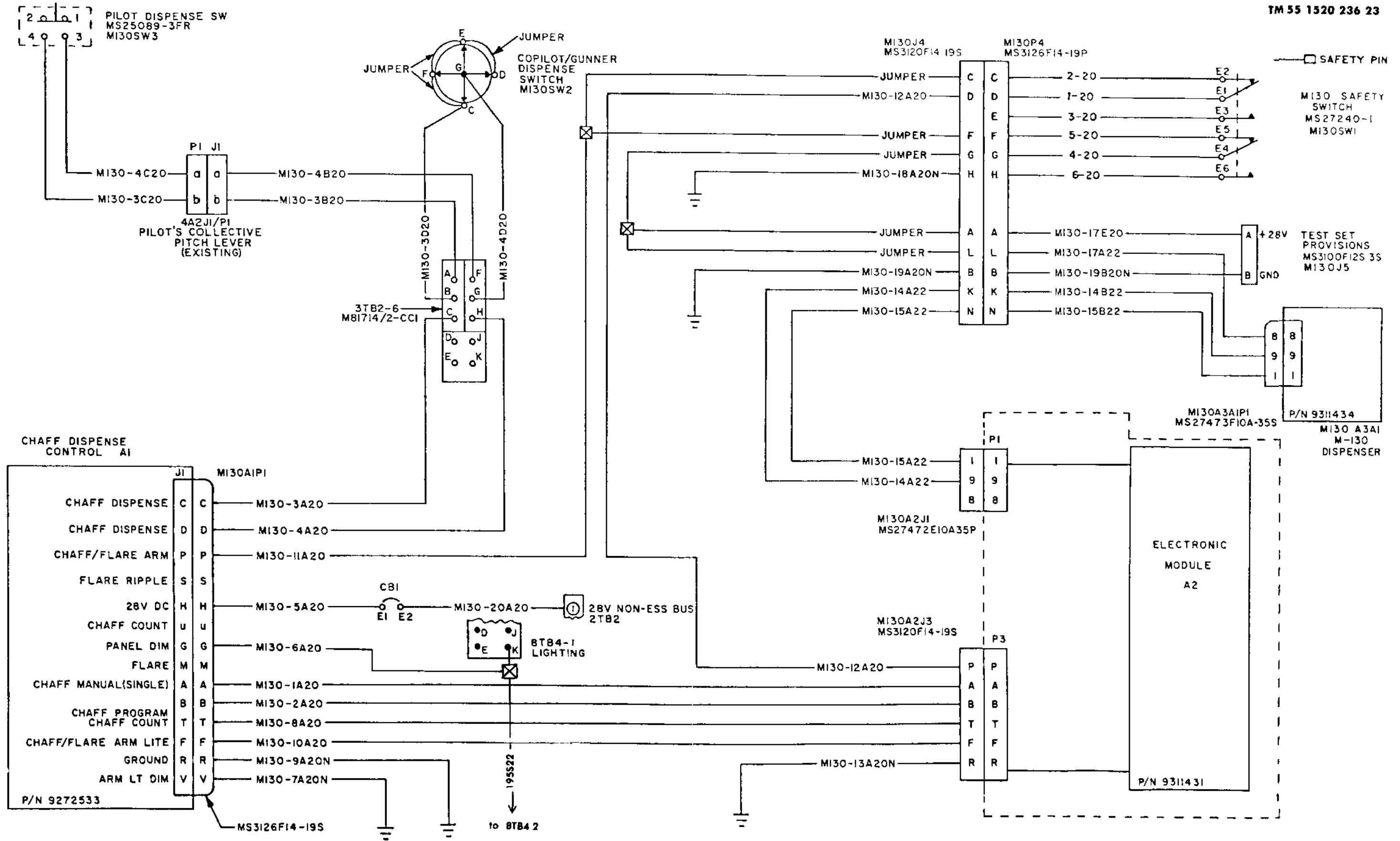

FO-2 1 M P E INTERFACE WIRING DIAGRAM (M 130)

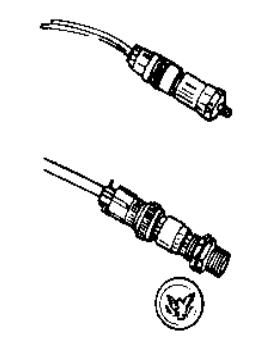

MAGNETIC PICKUP

MAGNETIC PICKUP switch is set to Common for all helicopter work so that both Accelerometer inputs are referenced to the same Magnetic Pickup pulse from the main rotor swashplate Independent is used only if two Magnetic Pickups are used as on left and right props of an airplane Then the left Accelerometer is compared to the left Magnetic Pickup and right to right

VERIFY TUNE RPM RANGE AND RPM TUNE

The heart of the Balancer is its tuneable electronic band pass filter The Accelerometer senses not only the one per-rev of the rotor being worked but all other vibrations as well These might be from other rotors n per-rev (where n = number of blades) shafts gears bearings engine etc The Balancer's filter is tuned by means of the RPM Range switch and RPM Tune dial to the one per rev of the rotor being worked The subsequent sections of the Balancer (measuring amplitude and phase) then deal only with the one per rev all other rates having been electrically rejected

Tuning of the electronic band pass filter to the exact rotor RPM is accomplished by simple manipulation of the Verify Tune button and RPM Tune dial TUNING IS IMPORTANT and instructions are found elsewhere in this TM and on the Track and Balance Charts

The filter is stagger tuned which means it has a broad top and sharp skirt characteristic This gives it considerable tolerance for RPM variation of the ship while retaining good rejection of other unwanted vibration signals When the Verify Tune button is pushed the filter is switched to a normal or sharp peak configuration This property

is used as a part of the tuning procedure and for troubleshooting

TROUBLESHOOTING

If there is an unknown vibratory disturbance an Accelerometer is mounted in the area where the disturbance is felt Then the RPM Tune dial is slowly turned until the meter peaks (reads maximum) It is best to peak the meter with the Verify Tune button depressed because the filter is sharper The RPM or vibration rate of the disturbance is then read directly from the RPM Tune dial (and RPM Range switch)

It is obvious that if the meter reads near zero there is no vibration at the indicated rate of the point to which the Accelerometer is attached

Knowing the vibration rate the source of the disturbance can usually be located keeping in mind that it might be shaft rate blade rate or multiples thereof or gear clash rate etc

ACCELEROMETER

Senses vibration from out of track or out of balance rotors and parts

MAGNETIC PICKUP

Triggers Strobex and provides phase reference for Phazor

STROBEX RECEPTACLE

28 V D C POWER

ACCELEROMETER INPUTS

Channels A and B are identical but are used as described only to establish a convention and avoid careless errors These Accelerometer inputs are also used for troubleshooting vibrations in which case the Accelerometer may be placed wherever the vibration is felt Then the RPM Tune dial is adjusted until the meter peaks and the RPM (rate) of the disturbance is read directly from the dial

Channel A Accelerometer typically used to measure lateral one per rev for main rotor balance

Channel B Accelerometer typically used to measure vertical one per-rev for main rotor track adjustment Also used for tail rotor balancing

MAGNETIC PICKUP INPUTS

Magnetic Pickup signal from swashplate assembly is used to trigger Strobex when Function switch is set to Track and as a rotor azimuth reference against which the Clock Angle of the Accelerometer signal is measured when Function switch is set to A or B

This Magnetic Pickup receptacle is used when two pickups are in use as for left and right propellers of an airplane

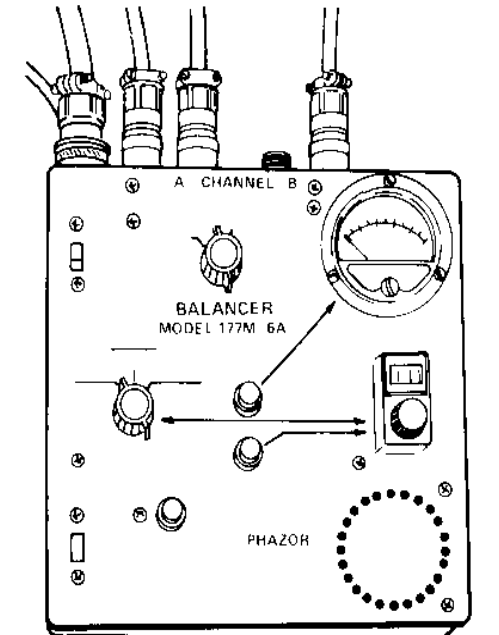

INTERRUPTER LOGIC

Since the rotating swashplate is fitted with two Interrupters one of which is double the Interrupter Logic switch is set to Double The Phazor then responds only to the double pulse which is the one per rev phase reference needed for the Phazor

TEST BUTTON

When the Test button is pushed the Accelerometer signals are disconnected and the Magnetic Pickup signal is fed into itself This causes the 12 00 and 6 00 o clock lights to light

IMPORTANT

The 12 00 and 6 00 o clock lights must be seen or Phazor is not ready to use

PHAZOR RING OF LIGHTS

This is a phase meter which measures the Clock Angle between the rotor azimuth angle derived from the Magnetic Pickup and the oscillating Accelerometer signal This Clock Angle plotted on the Chart tells WHERE to change weight or pitch-link to smooth the rotor

NOTE

Tail rotors are not fitted with Magnetic Pickups so the Strobex is used instead of the Phazor to measure Clock Angle

METER

Meter reads vibration amplitude in IPS (Inches Per Second) This is the velocity of the measured point as it goes thru the zero crossing of its oscillatory (vibratory) motion Scale #1 reads 0 to 10 IPS

Push for Scale 2 button is pushed if reading is off scale Then the Balancer reads 0 to 10 IPS

Vibration amplitude plotted on the Chart tells HOW MUCH weight or track change is required to smooth the rotor

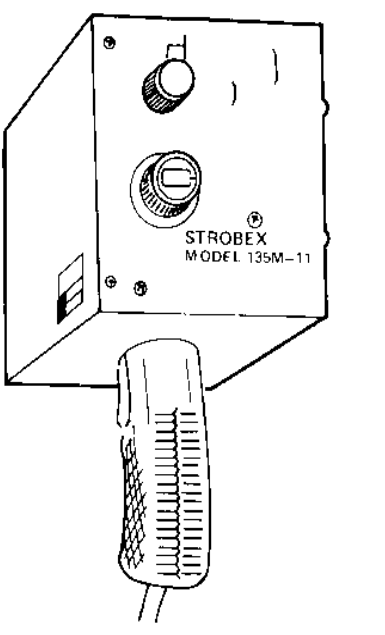

TRIGGER SWITCH

Turns DC Power on and off

STROBEX CABLE

Plugs into Strobex receptacle of Balancer

STROBEX

The Strobex Tracker model 135M 11 is a small hand held lightweight point source strobelamp designed especially for helicopter blade tracking and balancing both on the ground and in flight It is used to illuminate retro-reflective Targets secured to blade tips for tracking or on tail rotor blade grips for balancing By virtue of the point source narrow extremely bright beam it can be used effectively day or night in all kinds of weather including bright sunlight

The 135M 11 Strobex Tracker is used with a 177M 6A Balancer for tracking and balancing It may also be used as a conventional speed measuring strobe in which case the RPM of shafts rotors and accessories may be read directly

The 135M 11 Strobex has a trigger in the pistol grip handle for DC power switching a five position mode switch and a 10 turn RPM dial to adjust the flash rate

Positions A D and E operate at low intensity and to high flash rates and B and C operate at higher intensity (about 4 times) but to lower maximum flash rates The lower intensity is adequate for viewing the reflective targets on all but the biggest helicopters in any kind of daylight

The five modes of operation are

A — — — When set to A the Strobex operates a slave mode flashing only when commanded by the Balancer and is used for main rotor tracking and tail rotor balancing

The rotating swashplate is fitted with two Interrupters (one of which is double because of the Phazor) When the Balancer is set to track the Strobex will flash twice per revolution illuminating each of the two blade tips when they pass the front of the helicopter (and also when they pass over the tailboom) Thus the two Tip Targets will be seen superimposed at the front of the helicopter (They can also be seen over the tailboom but this is not useful except for ground

tracking) Since one Tip Target has a reflective horizontal bar and the other has a vertical bar the judgment of track is simple The reflective Targets face inboard so they are viewed from the cabin either on the ground or in flight

When an Accelerometer is secured on the tail rotor gearbox and connected to the Channel B input and the Balancer is switched to B the Strobex will flash once per rev in response to the vibration signal induced by the out of balance rotor

When a reflective Target secured to the rotor hub is viewed from a distance with the Strobex the Target will appear stopped at some angle This is the Clock Angle to be entered on the Balance Chart and will tell where to change weight

B — — — Position B is also used for main rotor tracking where higher intensity light is required The unique locking oscillator of position B is typically used for the larger rotors with multiple (4 5 angle) blades In those cases only one single Interrupter is secured to the rotating swashplate and the oscillator causes the Strobex to flash for the other blades By fine adjustment of the Strobex RPM control the blades may be spread for easy resolution

When applied to the two blade rotor systems (BELL) where two Interrupters are installed on the swashplate position B is used for greater light output The oscillator is set to flash at a rate slightly slower than blade rate (in accordance with the formula on the back of the Strobex RPM = blade rate X 0.4)

Then the Interrupter commands the Strobex before the oscillator and it operates as if there were no oscillator In this case the Targets cannot be spread

The oscillator may be set to double the blade rate in which case the Tip Targets will be seen at twice as many positions around the rotor disc For instance the Targets of a two blade rotor are typically seen at 12 00 and 6 00 o'clock (as determined by location of Interrupters) If the oscillator is set to double the blade rate the Targets will also be seen at 3 00 and 9 00 o'clock

C — — — This is a free running oscillator and is used as a tachometer for speed (RPM) measuring All external signals are disconnected and the Strobex flashes only in response to its internal oscillator Flash rate is adjustable from 100 to 1 000 RPM (flashes per minute)

D — — — This is also a free running oscillator and is used for tail rotor tracking as well as speed measuring Since there is no Magnetic Pickup mounted on the tail rotor the flash rate of the free-running oscillator is adjusted to double or four times the rotor rate (for a two blade tail rotor) so the single grip target appears as a stopped image of two or four Then by viewing the rotor disc edge on from the cabin door reflective Tip Targets can be seen superimposed for a judgment of track Flash rate from 1 000 to 10 000 RPM

E — — — This is a locking oscillator like B but operates at higher rates and is used for viewing the track of airplane propellers Requires a Magnetic Pickup input pulse

EQUIPMENT	PART DESIGNATION	NOTES	NO OF UNITS	OPER TIME MIN	ELECTRICAL REQUIREMENTS PER UNIT								
					115 VOLTS 3 PHASE			115 VOLTS 1 PHASE			26 VOLTS 1 PHASE		
					VA	WATTS	VARs	VA	WATTS	VARs	VA	WATTS	VARs
AC BUS SYSTEM TOW OFF													
26 VAC (TOW NOT ENERGIZED)													
FLIGHT INSTRUMENTS COURSE IND	212 070 180 3		1	15 00							9 12	1 46	9 00
RADIO NAV & COMM LF ADF REC VOR LOC GS	AN/ARN 89 AN/ARN 123		1 1	15 00 15 00							4 01 10 40	2 52 8 32	3 12 6 24
AC POWER PF COR CAP	5 MFD 100V		1	15 00							8 60	1 71	8 43
115 VAC (TOW NOT ENERGIZED)													
ARMAMENT HELMENT ST TURRET CUN	XM 28		1 1	15 00 15 00				13 35 17 92	13 35 9 14	0 0 15 41			
FLIGHT CONTROLS STAB AUG SYS	570 947 001		1	15 00				16 59	15 21	6 62			
ENGINE INSTRUMENTS FUEL QTY SYS FUEL QTY IND FUEL QTY XMR	209 060 602		1 1 2	15 00				2 92	2 91	0 26			
FLIGHT INSTRUMENTS COMPASS SYS DIR GYRO XMTR SERVO AMP ATT GYRO RATE SW GYRO HSI IND PLT ATT IND	AN/ASN 43 CN/998( )/ASN T 611( )/ASN AM 3209/ASN LEAR-SIGLER 9000C TYPE MC I 209 070 660 209 076 661 1		1 1 1 1 1 1 1 1 1	15 00				16 39 12 32 17 92 4 91 25 00 10 00	15 36 12 00 15 93 1 21 20 00 9 39	5 73 -2 79 8 21 -4 76 15 00 3 44			
AC POWER MAIN INVRLY	214 075 150 1		1	15 00				5 10	5 07	0 51			
AC BUS SYSTEM TOW ON													
26 VAC (WITH TOW ENERGIZED)													
FLIGHT INSTRUMENTS COURSE IND	212 070 180 3		1	15 00							9 12	1 46	9 00
RADIO NAV & COMM LF ADF REC VOR LOC GS	AN/ARN 89 AN/ARN 123		1 1	15 00 15 00							4 01 10 40	2 52 8 32	3 12 6 24
AC POWER PF COR CAP	5 MFD 100 V		1	15 00							8 60	1 71	8 43
115 VAC (WITH TOW ENERGIZED)													
ARMAMENT TOW REF S1 TOW MIS SY HELMENT ST TUR CONT 3PH	XM 65 XM 65 XM 28		1 1 1 1	15 00 15 00 15 00 15 00	27 92 110 64	24 63 104 23	13 14 37 11			13 35	13 35	0 0	
FLIGHT CONTROLS STAB AUG SYS	570 947 001		1	15 00	17 81	9 21	15 24	16 59	15 21	6 62			

EQUIPMENT	PART DESIGNATION	NOTES	NO OF UNITS	OPER TIME MIN	ELECTRICAL REQUIREMENTS PER UNIT								
					115 VOLTS 3 PHASE			115 VOLTS 1 PHASE			26 VOLTS 1 PHASE		
					VA	WATTS	VARs	VA	WATTS	VARs	VA	WATTS	VARs
ENGINE INSTRUMENTS													
FUEL QTY SYS	209 060 662		1	15 00				2 92	2 91	0 26			
FUEL QTY IND			1										
FUEL QTY XMR			2										
FLIGHT INSTRUMENTS													
COMP ASSY SYS	AN/ASN 43		1										
DIR GYRO	CN/998( )/ASN		1	15 00				16 39	15 36	5 73			
XMTR	T 611( )/ASN		1										
SERVO AMP	AM 3209/ASN		1	15 00				12 32	12 00	-2 79			
ATT GYRO	LEAR-SIGLER 9000C		1	15 00	17 94	15 93	8 25						
RATE SW GYRO	TYPE MC-1		1	15 00	4 89	1 20	4 74						
HSI IND	209 070 660		1	15 00				25 00	20 00	15 00			
ATT IND3PH	209 075 661 1		1	15 00				3 52	3 33	1 15			
AC POWER													
MAIN INV RLY	214 075 150 1		1	15 00				5 10	5 07	0 51			

209099-25-2

EQUIPMENT	PART DESIGNATION	NOTES	NO OF UNITS	OPFR TIME MIN	VOLTAGE		FREQ		PWR SDR INF	PWR FACT	PHASE A TO B		CONNECTED LOADS PHASE B TO C		PHASE C TO A	
					MIN	MAX	MIN	MAX			WATTS	VAR	WATTS	VAR	WATTS	VAR
AC BUS SYS TOW OFF																
26 VAC (TOW NOT ENERGIZED)																
FLIGHT INSTRUMENTS																
COURSE IND	212 070 180 3		1	15 00	24 5	27 5	380	420	SPEC	0 160				1 46	9 00	
RADIO NAV & COMM																
LF ADF REC	AN/ARN 89		1	15 00	24 5	27 5	380	420	MEA	0 629						
VOR LOC GS	AN ARN 123		1	15 00	24 5	27 5	380	420	SPEC	0 800				2 52	3 12	
AC POWER														8 32	6 24	
PF COR CAP	5 MFD 100V		1	15 00	24 5	27 5	360	440	MEA	0 189						
TOTAL 26 VAC (TOW NOT ENERGIZED)														1 71	8 43	
115 VAC (TOW NOT ENERGIZED)														14 01	9 93	
ARMAMENT														17 17 VA AT		
HELMET ST			1	15 00	107 5	119 5	380	420	MEA	1 000	13 35	0 0				
TURRET CON	XM 28		1	15 00	108 0	118 0	360	440	MEA	0 510	9 14	15 41				
FLIGHT CONTROLS																
STAB AUG SYS	570 047 001		1	15 00	108 0	118 0	380	420	MEA	0 917	15 21	6 62				
ENGINE INSTRUMENTS																
FUEL QTY SYS																
FUEL QTY IND	209 060 602		1	15 00	107 5	119 5	360	440	MEA	0 996	2 91	0 26				
FUEL QTY XMR			1													
			2													
FLIGHT INSTRUMENTS																
COMPASS SYS																
DIP GYRO	AN/ASN 43		1													
XMR	CN/9981 )/ASN		1	15 00	108 0	118 0	380	420	MEA	0 937				15 36	5 73	
SERVO AMP	T 611( ) ASN		1													
ATT GYRO	AM 3209 ASN		1	15 00	108 0	118 0	380	420	MEA	0 974						
RATE SW GYRO	LEAR SIGLER 9000C		1	15 00	108 0	118 0	380	420	MEA	0 889	15 93	8 21		12 00	2 79	
HSI IND	TYPE MC-1		1	15 00	108 0	118 0	380	420	MEA	-0 247	1 21	-4 76				
PLT ATT IND	209 070 660		1	15 00	108 0	118 0	380	420	MEA	0 800						
	209 075 661 1		1	15 00	108 0	118 0	380	420	SPEC	0 939	9 39	3 44		20 00	15 00	
AC POWER																
MAIN INV RLY	214 075 150 1		1	15 00	108 0	118 0	360	440	MEA	-0 995	5 07	-0 51				
TOTAL 115 VAC (TOW NOT ENERGIZED)														72 22	28 67	
														77 70 VA AT		
														0 929 PF LAG		
TOTAL PER PHASE 26 VAC & 115 VAC AC BUS SYS TOW OFF														47 36	17 93	
														50 64 VA AT		
														0 935 PF LAG		
TOTAL 3 PHASE AC BUS SYS TOW OFF														72 22	28 67	
														61 37	27 86	
														77 70 VA AT		
														0 911 PF LAG		
														133 59	56 54	
														145 06 VA AT	0 921 PF LAGGING	

EQUIPMENT	PART DESIGNATION	NOTES	NO OF UNITS	OPFR TIME MIN	VOLTAGE		FREQ		PWR SCR INF	PWR FACT	PHASE A TO B		CONNECTED LOADS PHASE B TO C		PHASE C TO A	
					MIN	MAX	MIN	MAX			WATTS	VAR	WATTS	VAR	WATTS	VAR
AC BUS SYS TOW ON																
26 VAC (WITH TOW ENERGIZED)																
FLIGHT INSTRUMENTS																
COURSE IND	212 070 180 3		1	15 00	24 5	27 5	380	420	SPEC	0 160			1 46	9 00		
RADIO NAV & COMM																
LF/ADF REC	AN/ARN 89		1	15 00	24 5	27 5	380	420	MEA	0 629			2 52	3 12		
VOR/LOC/GS	AN/ARN 123		1	15 00	24 5	27 5	380	420	SPEC	0 800			8 32	6 24		
AC POWER																
PF COR CAP	5 MFD 100V		1	15 00	24 5	27 5	360	440	MEA	0 199						
TOTAL 26 VAC (WITH TOW ENERGIZED)																
115 VAC (WITH TOW ENERGIZED)																
ARMAMENT																
TOW REF SI	XM 65		1	15 00	108 5	117 5	380	420	MEA	-0 882	11 53	9 22				
TOW MIS SY	XM 65		1	15 00	108 5	117 5	380	420	MEA	0 942	24 29	37 01	-25 09	2 38	11 07	18 98
HELEMENT ST			1	15 00	107 5	119 5	380	420	MEA	1 000			32 20	24 13	47 74	24 03
TUR CONT 3PH	XM 28		1	15 00	108 0	118 0	360	440	MEA	0 517	3 07	5 08	13 35	0 0		
FLIGHT CONTROLS																
STAB AUG SYS	570 947 001		1	15 00	108 0	118 0	380	420	MEA	0 917	15 21	6 62	3 07	5 08	3 07	5 08
ENGINE INSTRUMENTS																
FUEL QTY SYS	209 060 602		1	15 00	107 5	119 5	360	440	MEA	0 996	2 91	0 26				
FUEL QTY IND			1													
FUEL QTY XMR			2													
FLIGHT INSTRUMENTS																
COMPASS SYS	AN/ASN 43		1													
DIR GYRO	CN/698( )/ASN		1	15 00	108 0	118 0	380	420	MEA	0 937			15 36	5 73		
XMTR	T 611( )/ASN		1													
SERVO AMP	AM 3209/ASN		1	15 00	108 0	118 0	380	420	MEA	-0 974			12 00	-2 79		
ATT GYRO	LEAR-SIGLER 9000C		1	15 00	108 0	118 0	380	420	MEA	0 888	5 31	2 75	5 31	2 75	5 31	2 75
RATE SW GYRO	TYPE MC 1		1	15 00	108 0	118 0	380	420	MEA	0 246	0 40	1 58	0 40	-1 58	0 40	1 58
HSI IND	209 070 680		1	15 00	108 0	118 0	380	420	MEA	0 800	20 00	15 00				
ATT IND 3PH	209 075 661 1		1	15 00	108 0	118 0	380	420	SPEC	0 945			3 33	1 15		
AC POWER																
MAIN INV RLY	214 078 150 1		1	15 00	108 0	118 0	360	440	MEA	0 995	5 07	0 51				
TOTAL 115 VAC (WITH TOW ENERGIZED)																
TOTAL PER PHASE 26 VAC & 115 VAC AC BUS SYS TOW ON																
TOTAL 3 PHASE AC BUS SYS TOW ON																
											87 80	56 41	59 93	36 84	45 45	1 20
											104 36 VA AT		70 35 VA AT		45 47 VA AT	
											0 841 PF LAG		0 852 PF LAG		1 000 PF LAG	
											87 80	56 41	73 94	46 77	45 45	1 20
											104 36 VA AT		87 49 VA AT		45 47 VA AT	
											0 841 PF LAG		0 845 PF LAG		1 000 PF LAG	
													207 18	104 38		
													231 99 VA AT 0 893 PF LAGGING			



EQUIPMENT	PART DESIGNATION	NOTES	NO OF UNITS	AMPS PER UNIT	OPER TIME MIN	MIN VOLT	MAX VOLT	PWR SOR INF	CONN LOAD	OPERATING CONDITIONS											
										ESSENTIAL DC BUS						START AND WARM-UP			TAKE OFF		
										5 SEC	2 MIN	15 MIN	5 SEC	2 MIN	15 MIN	5 SEC	2 MIN	15 MIN			
ARMAMENT										ESSENTIAL DC BUS											
NOSE ARMAMENT	M28A1E1		1																		
GUN DRIVE MTR		6	1																		
GUN CONTROL PR			1	60 0	0 0	24 00	28 50	SPEC	60 00												
MACHINE GUN	XM 18 (7.62MM)	7	2	23 00	2 00	24 00	28 50	SPEC	23 00												
MACH GUN FIRE			2																		
MACH GUN BAT CHG			2	1 00	0 25	21 00	29 00	MEA	2 00												
ARM PWR RELAY	MS24183D1		2	9 90	0 50	21 00	29 00	MEA	19 80												
TOW MISSILE SYS	XM 65		1	0 40	15 00	24 00	28 50	MEA	0 40												
TOW MISSILE	XM 65		1																		
3P/1P INV RLY	110 111 1	7	1	8 10	15 00	21 00	29 00	MEA	8 10												
ROCKET LAUNCH	BHC ( C INTERVAL 0)		1	0 18	15 00	18 00	29 00	SPEC	0 18												
SQUIB WGN ST JT	ARD863 1		2	2 50	0 0	24 00	28 50	SPEC	5 00												
			8	1 60	0 0	21 00	29 00	MEA	12 80												
FLIGHT CONTROLS																					
STAB AUG SYS	570 947 001		1	0 92	15 00	24 00	28 50	SPEC	0 92												
HYD VALVE SOL	HYD RESEARCH 88700	1	2	1 10	0 0	21 00	29 00	SPEC	0 92												
MAG BKE FR TRM	ABN ACC R460M15 3		3	0 35	15 00	21 00	29 00	MEA	2 20												
EMER HYD PUMP	209 076 025		1	40 00	0 0	21 00	29 00	MEA	1 05												
EMER HYD SOL	204 078 504 3		2	0 50	0 0	21 00	29 00	SPEC	40 00												
EMER HYD RLY	110 127 D1		1	0 12	0 0	21 00	29 00	SPEC	1 00												
			1						0 12												
INSTRUMENTS																					
XMSN OILT/PIND	209 075 658		1	0 11	15 00	21 00	29 00	SPEC	0 11												
ENGINE INSTRUMENTS																					
TURBINE TEMP IND	209 075 651		2	0 11	15 00	21 00	29 00	SPEC	0 11												
GAS PRODUCR IND	209 075 652		2	0 11	15 00	21 00	29 00	SPEC	0 22												
TORQ PRESS IND	209 075 653		1	0 11	15 00	21 00	29 00	SPEC	0 22												
TORQ PRESS IND	209 075 654		1	0 11	15 00	21 00	29 00	SPEC	0 11												
DUAL TACH IND	209 075 655		2	0 11	15 00	21 00	29 00	SPEC	0 11												
ENG OIL T/P IND	209 075 656		1	0 11	15 00	21 00	29 00	SPEC	0 11												
FLIGHT INSTRUMENTS																					
TURN & SLIP IND	MI 7805AMS28024 3		1	0 10	15 00	24 00	28 50	SPEC	0 10												
GNR ATT IND	209 075 666 1		1	0 37	15 00	21 00	29 00	SPEC	0 37												
HEATING																					
DEICING VALVE	VAPAIR 25830029	3	1	0 90	15 00	24 00	28 50	SPEC	0 90												
ENGINE IGNITION																					
IGNITOR SYSTEM	PART OF ENGINE	4	1	2 15	0 0	24 00	28 50	SPEC	2 15												
IGNITOR PACK	PART OF ENGINE	4	1																		
ENG PRIM SOL	PART OF ENGINE	4	1																		
ENGINE CONTROLS																					
STARTER RELAY	MS24183D1	4	1	0 37	0 0	24 00	28 50	MEA	0 37												
LIGHTING																					
INST & EDGE LTS	MS25237 327 LAMP	2	126	0 04	15 00	24 00	28 50	MEA	5 04												
COCKPIT LIGHT	GRIMES 15 007 43		3	0 17	1 00	24 00	28 50	SPEC	0 51												
PLT INST LTS	212 075 962 1		3	2 00	15 00	24 00	28 50	SPEC	6 00												
CPLT INST LTS	212 075 962 1		1	2 00	15 00	24 00	28 50	SPEC	2 00												
POWER																					
N-ESS BUS PR RLY	MS24183D1		1	0 40	15 00	24 00	28 50	MEA	0 40												
BATTERY CHGNG	BB 649/A		1																		
BUS CONT RLY	MS24149D1	5	1	0 17	15 00	24 00	28 50	SPEC	0 17												
BATTERY RELAY	MS24183D1		1	0 40	15 00	18 00	29 00	MEA	0 40												

EQUIPMENT	PART DESIGNATION	NOTES	NO OF UNITS	AMPS PER UNIT	OPER TIME MIN	MIN VOLT	MAX VOLT	PWR SOR INF	CONN LOAD	OPERATING CONDITIONS							
										START AND WARM-UP			TAKE OFF				
										5 SEC	2 MIN	15 MIN	5 SEC	2 MIN	15 MIN		
ESSENTIAL DC BUS																	
FUEL CONTROL																	
FUEL BOOST PUMP	205-060 606		1	3.20	15.00	24.00	28.50	MEA	3.20		3.20	3.20	3.20		3.20	3.20	3.20
FUEL SOFF VALVE	204 062 520		1	2.00	0.02	18.00	29.00	MEA	2.00		0.48	0.02	0.00				
FUEL CONT VALVE	GW LIST CECO		1	1.30	15.00	24.00	28.50	SPEC	1.30		1.30	1.30	1.30		1.30	1.30	1.30
GOV RPM ACT	204 060 762		1	0.90	1.00	24.00	28.50	SPEC	0.90		0.90	0.45	0.06				
IDLE STOP SOL	GW LISK L 2540		1	4.60	0.03	24.00	28.50	SPEC	4.60								
FUEL LOW RLY	GE 352791G200F 9	1	1	0.0	0.0	24.00	28.50	SPEC	0.0								
OIL BY PASS SOL	AV2381106B		1	2.00	0.05	24.00	28.50	SPEC	2.00		1.20	0.05	0.01				
OIL BY PASS RLY	ALLIED MHB 60	1	1	0.11	0.0	24.00	28.50	SPEC	0.11								
RADIO NAV AND COMM																	
UHF AM RADIO	AN/ARC 116		1														
UHF AM RECEIVE	AN/ARC 116		1	0.80	15.00	24.00	28.50	MEA	0.80		0.80	0.80	0.80		0.80	0.80	0.80
UHF AM XMITER	AN/ARC 116	2	1	3.00	1.00	24.00	28.50	MEA	3.00		3.00	1.50	0.42		3.00	1.50	0.42
INTERCOM SYS	C6533/ARC		2	0.07	15.00	24.00	28.50	MEA	0.14		0.14	0.14	0.14		0.14	0.14	0.14
VOR LOC 'GS/M8	AN/ARN 123		1	0.39	15.00	24.00	28.50	SPEC	0.39		0.39	0.39	0.39		0.39	0.39	0.39
RADAR																	
IFF TRANSPONDER	AN/APX 72		1	3.80	15.00	21.00	29.00	MEA	3.80		3.80	3.80	3.80		3.80	3.80	3.80
TEST SET	TS 1843/AFX	8	1	0.70	15.00	21.00	29.00	MEA	0.70		0.70	0.70	0.70		0.70	0.70	0.70
COMPUTER KIT	TA/TSEC MARK XII	8	1	1.10	15.00	24.00	28.50	SPEC	1.10		1.10	1.10	1.10		1.10	1.10	1.10
RADAR ALTIMETER	AN/APN 209		1	2.00	15.00	24.00	28.50	SPEC	2.00		2.00	2.00	2.00		2.00	2.00	2.00
RADAR WARNING	AN/APR 38		1	1.10	15.00	24.00	28.50	SPEC	1.10		1.10	1.10	1.10		1.10	1.10	1.10
PROX WARNING	YG 1054		1	1.50	15.00	24.00	28.50	SPEC	1.50		1.50	1.50	1.50		1.50	1.50	1.50
INVERTER																	
MAIN INVERTER	209 075 572		1		15.00	24.00	28.50	SPEC			8.84	8.84	8.84		8.84	8.84	8.84
ADDTL TOW MAIN	209 075 572		1		15.00	24.00	28.50	SPEC									
MAIN INV PWR RLY	MS24140D2		1	0.36	15.00	24.00	28.50	SPEC	0.36		0.36	0.36	0.36		0.36	0.36	0.36
AC PWR CONT RLY	110 128 1		1	0.11	15.00	24.00	28.50	SPEC	0.11		0.11	0.11	0.11		0.11	0.11	0.11
INV SELECT RLY	110 111 1		1	0.20	15.00	24.00	28.50	SPEC	0.20		0.20	0.20	0.20		0.20	0.20	0.20
WARNING AND EMERGENCY																	
CAUT LT PANEL	204 075 705		1	0.20	15.00	24.00	28.50	SPEC	0.20		0.20	0.20	0.20		0.20	0.20	0.20
RPM LIMIT WARN	205 074 001		1	0.30	15.00	24.00	28.50	SPEC	0.30		0.30	0.30	0.30		0.30	0.30	0.30
FIRE DETECTION	209 075 395		1	0.07	15.00	24.00	28.50	MEA	0.07		0.07	0.07	0.07		0.07	0.07	0.07
RPM WARN LIMIT	209 075 326		1	0.98	15.00	24.00	28.50	MEA	0.98		0.98	0.98	0.98		0.98	0.98	0.98
MAST CAUT SYS	209 075 325		1	0.20	15.00	21.00	29.00	MEA	0.20		0.20	0.20	0.20		0.20	0.20	0.20
TOTAL ESSENTIAL DC BUS											119.28	97.86	68.37		71.24	67.59	56.34

EQUIPMENT	PART DESIGNATION	NOTES	NO OF UNITS	AMPS PER UNIT	OPER TIME MIN	MIN VOLT	MAX VOLT	PWR SOR INF	CONN LOAD	OPERATING CONDITIONS							
										START AND WARM-UP			TAKE OFF				
										5 SEC	2 MIN	15 MIN	5 SEC	2 MIN	15 MIN		
NON-ESSENTIAL DC BUS																	
FLIGHT INSTRUMENTS																	
PITOT HEATER	AN5813 1		1	3.75	15.00	24.00	28.50	SPEC	3.75		3.75	3.75	3.75		3.75	3.75	3.75
HEATING																	
ECU	209 070 403		1	0.30	15.00	24.00	28.50	SPEC	0.30		0.30	0.30	0.30		0.30	0.30	0.30
BLEED AIR SOL	397580 1 1		1	0.80	15.00	24.00	28.50	SPEC	0.80		0.80	0.80	0.80		0.80	0.80	0.80
RAIN REMOV SOL	JANITROL 43070		1	0.64	15.00	24.00	28.50	SPEC	0.64		0.64	0.64	0.64		0.64	0.64	0.64
HTR CONT RELAY	MS24149DI	1	1	0.20	0.0	24.00	28.50	SPEC	0.20						0.64	0.64	0.64
TOW BLOWER	209 073 115		1	28.00	15.00	24.00	28.50	SPEC	28.00		28.00	28.00	28.00		28.00	28.00	28.00
TOW BLOWER RLY	MS24181D1		1	0.40	15.00	24.00	28.50	SPEC	0.40		0.40	0.40	0.40		28.00	28.00	28.00
LIGHTING															0.40	0.40	0.40
SIDE POSITI LTS	AN3033 12 13		2	0.80	15.00	24.00	28.50	SPEC	1.60		1.60	1.60	1.60		1.60	1.60	1.60
SEARCH LIGHT	FSN6620 283 9767		1	16.70	5.00	24.00	28.50	SPEC	16.70		1.60	1.60	1.60		1.60	1.60	1.60
ANTICOLLISION LT	MIL L 98085		1	2.15	15.00	24.00	28.50	SPEC	2.15		2.15	2.15	2.15		2.15	2.15	2.15
TAIL POSITION LT	GR30 0003 15 1683		2	0.90	15.00	24.00	28.50	SPEC	1.80		1.80	1.80	1.80		1.80	1.80	1.80
POS LTS FLASHER	MS24577 2		1	0.40	15.00	21.00	29.00	MEA	0.40		0.40	0.40	0.40		0.40	0.40	0.40
FUEL CONTROL																	
FUEL BOOST PUMP	205 060 606		1	3.20	15.00	24.00	28.50	MEA	3.20		3.20	3.20	3.20		3.20	3.20	3.20
RADIO NAV & COMM																	
VHF FM RADIO	AN/ARC 114		1														
VHF FM RECEIVER	AN/ARC 114		1	0.70	15.00	24.00	28.50	MEA	0.70		0.70	0.70	0.70		0.70	0.70	0.70
VHF FM XMITER	AN/ARC 114		1	3.00	1.00	24.00	28.50	MEA	3.00		3.00	1.50	0.42		3.00	1.50	0.42
SCRAMBLER	KY 28	2	1	2.00	15.00	24.00	28.50	SPEC	2.00		2.00	2.00	2.00		2.00	2.00	2.00
ADF RECEIVER	AN/ARN 89		1	1.40	15.00	24.00	28.50	MEA	1.40		1.40	1.40	1.40		1.40	1.40	1.40
VHF AM RADIO	AN/ARC 115		1														
VHF AM RECEIVE	AN/ARC 115		1	0.62	15.00	24.00	28.50	MEA	0.62		0.62	0.62	0.62		0.62	0.62	0.62
VHF AM XMITER	AN/ARC 115	2	1	1.79	1.00	24.00	28.50	MEA	1.79		1.79	0.89	0.25		1.79	0.89	0.25
INVERTER																	
STBY INVERTER	TYPE PU 543( 1/A	1	1		0.0	24.00	28.50	SPEC			0.0	0.0	0.0		0.0	0.0	0.0
STBY INV PWR RLY	MS24140D1	1	1	0.31	0.0	24.00	28.50	SPEC	0.31		0.0	0.0	0.0		0.0	0.0	0.0
CHAFF DISPENSER	M 130	1	1	1.32	0.0	24.00	28.50	SPEC	1.32		0.0	0.0	0.0		0.0	0.0	0.0
TOTAL NON ESSENTIAL DC BUS											52.55	50.15	48.43		52.55	50.15	48.43
TOTAL ESSENTIAL + NON ESSENTIAL DC BUS											171.83	148.01	116.80		123.79	117.75	104.77



EQUIPMENT	PART DESIGNATION	NOTES	NO OF UNITS	AMPS PER UNIT	OPER TIME MIN	MIN VOLT	MAX VOLT	PWR SOR INF	CONN LOAD	OPERATING CONDITIONS								
										CRUISE			CRUISE - COMBAT					
										5 SEC	2 MIN	15 MIN	5 SEC	2 MIN	15 MIN			
<b>ESSENTIAL DC BUS</b>																		
FUEL CONTROL																		
FUEL BOOST PUMP	205 060 606		1	3.20	15 00	24 00	28 50	MEA	3.20		3.20	3.20	3.20		3.20	3.20	3.20	
FUEL SOFF VALVE	204 062 520		1	2.00	0 02	18 00	29 00	MEA	2.00									
FUEL CONT VALVE	GW LIST CECO		1	1.30	15 00	24 00	28 50	SPEC	1.30		1.30	1.30	1.30		1.30	1.30	1.30	
GOV RPM ACT	204 060 762		1	0.90	1 00	24 00	28 50	SPEC	0.90		0.90	0.45	0.06		0.90	0.45	0.06	
IDLE STOP SOL	GW LISK L 2540		1	4.60	0 03	24 00	28 50	SPEC	4.60									
FUEL LOW RLY	GE 352791G200F 9	1	1	0 0	0 0	24 00	28 50	SPEC	0 0									
OIL BY PASS SOL	AV2381106B		1	2.00	0 05	24 00	28 50	SPEC	2.00									
OIL BY PASS RLY	ALLIED MHB 60	1	1	0 11	0 0	24 00	28 50	SPEC	0 11									
RADIO NAV AND COMM																		
UHF AM RADIO	AN ARC 116		1															
UHF AM RECEIVE	AN ARC 116		1	0.80	15 00	24 00	28 50	MEA	0.80		0.80	0.80	0.80		0.80	0.80	0.80	
UHF AM XMITER	AN ARC 116	2	1	3.00	1 00	24 00	28 50	MEA	3.00		3.00	1.50	0.42		3.00	1.50	0.42	
INTERCOM SYS	C6533/ARC		2	0.07	15 00	24 00	28 50	MEA	0.14		0.14	0.14	0.14		0.14	0.14	0.14	
VOR LOC GS MB	AN/ARN 123		1	0.39	15 00	24 00	28 50	SPEC	0.39		0.39	0.39	0.39		0.39	0.39	0.39	
RADAR																		
IFF TRANSPONDER	AN APX 72		1	3.80	15 00	21 00	29 00	MEA	3.80		3.80	3.80	3.80		3.80	3.80	3.80	
TEST SET	TS 1843/APX	8	1	0.70	15 00	21 00	29 00	MEA	0.70		0.70	0.70	0.70		0.70	0.70	0.70	
COMPUTER KIT	TA/TSEC MARK XII		1	1.10	15 00	24 00	28 50	SPEC	1.10		1.10	1.10	1.10		1.10	1.10	1.10	
RADAR ALTIMETER	AN/APN 209		1	2.00	15 00	24 00	28 50	SPEC	2.00		2.00	2.00	2.00		2.00	2.00	2.00	
RADAR WARNING	AN/APR 39		1	1.10	15 00	24 00	28 50	SPEC	1.10		1.10	1.10	1.10		1.10	1.10	1.10	
PROX WARNING	YG 1054		1	1.50	15 00	24 00	28 50	SPEC	1.50		1.50	1.50	1.50		1.50	1.50	1.50	
INVERTER																		
MAIN INVERTER	209 075 572		1		15 00	24 00	28 50	SPEC			8.84	8.84	8.84					
ADDTL TOW MAIN	209 075 572		1		15 00	24 00	28 50	SPEC							12.88	12.88	12.88	
MAIN INV PWR RLY	MS24140D2		1	0.36	15 00	24 00	28 50	SPEC	0.36		0.36	0.36	0.36		0.36	0.36	0.36	
AC PWR CONT RLY	110 128 1		1	0.11	15 00	24 00	28 50	SPEC	0.11		0.11	0.11	0.11		0.11	0.11	0.11	
INV SELECT RLY	110 111 1		1	0.20	15 00	24 00	28 50	SPEC	0.20		0.20	0.20	0.20		0.20	0.20	0.20	
WARNING AND EMERGENCY																		
CAUT LT PANEL	204 075 705		1	0.20	15 00	24 00	28 50	SPEC	0.20		0.20	0.20	0.20		0.20	0.20	0.20	
RPM LIMIT WARN	205 074 001		1	0.30	15 00	24 00	28 50	SPEC	0.30		0.30	0.30	0.30		0.30	0.30	0.30	
FIRE DETECTION	209 075 395		1	0.07	15 00	24 00	28 50	MEA	0.07		0.07	0.07	0.07		0.07	0.07	0.07	
RPM WARN LIMIT	209 075 326		1	0.98	15 00	24 00	28 50	MEA	0.98		0.98	0.98	0.98		0.98	0.98	0.98	
MAST CAUT SYS	209 075 325		1	0.70	15 00	21 00	29 00	MEA	0.70		0.20	0.20	0.20		0.20	0.20	0.20	
TOTAL ESSENTIAL DC BUS											60.22	57.11	51.08		111.93	93.05	65.70	

EQUIPMENT	PART DESIGNATION	NOTES	NO OF UNITS	AMPS PER UNIT	OPER TIME MIN	MIN VOLT	MAX VOLT	PWR SOR INF	CONN LOAD	OPERATING CONDITIONS							
										CRUISE			CRUISE - COMBAT				
										5 SEC	2 MIN	15 MIN	5 SEC	2 MIN	15 MIN		
NON-ESSENTIAL DC BUS																	
FLIGHT INSTRUMENTS																	
PITOT HEATER	AN5813 1		1	3.75	15.00	24.00	28.50	SPEC	3.75	3.75	3.75	3.75	3.75	3.75	3.75	3.75	3.75
HEATING																	
ECU	209 070 403		1	0.30	15.00	24.00	28.50	SPEC	0.30	0.30	0.30	0.30	0.30	0.30	0.30	0.30	0.30
BLEED AIR SOL	397580 1 1		1	0.80	15.00	24.00	28.50	SPEC	0.80	0.80	0.80	0.80	0.80	0.80	0.80	0.80	0.80
RAIN REMOV SOL	JANITROL 43070		1	0.64	15.00	24.00	28.50	SPEC	0.64	0.64	0.64	0.64	0.64	0.64	0.64	0.64	0.64
HTR CONT RELAY	MS24149DI	1	1	0.20	0.0	24.00	28.50	SPEC	0.20								
TOW BLOWER	209 073 115		1	28.00	15.00	24.00	28.50	SPEC	28.00	28.00	28.00	28.00	28.00	28.00	28.00	28.00	28.00
TOW BLOWER RLY	MS24181D1		1	0.40	15.00	24.00	28.50	SPEC	0.40	0.40	0.40	0.40	0.40	0.40	0.40	0.40	0.40
LIGHTING																	
SIDE POSITI LTS	AN3033 12 -13		2	0.80	15.00	24.00	28.50	SPEC	1.60	1.60	1.60	1.60	1.60	1.60	1.60	1.60	1.60
SEARCH LIGHT	FSN6620 283 9767		1	16.70	5.00	24.00	28.50	SPEC	16.70	16.70	16.70	5.57					
ANTICOLLISION LT	MIL L 98085		1	2.15	15.00	24.00	28.50	SPEC	2.15	2.15	2.15	2.15	2.15	2.15	2.15	2.15	2.15
TAIL POSITION LT	GR30 0003 15 1683		2	0.90	15.00	24.00	28.50	SPEC	1.80	1.80	1.80	1.80	1.80	1.80	1.80	1.80	1.80
POS LTS FLASHER	MS24577 2		1	0.40	15.00	21.00	29.00	MEA	0.40	0.40	0.40	0.40	0.40	0.40	0.40	0.40	0.40
FUEL CONTROL																	
FUEL BOOST PUMP	205 060 606		1	3.20	15.00	24.00	28.50	MEA	3.20	3.20	3.20	3.20	3.20	3.20	3.20	3.20	3.20
RADIO NAV & COMM																	
VHF-FM RADIO	AN/ARC 114		1														
VHF-FM RECEIVER	AN/ARC 114		1	0.70	15.00	24.00	28.50	MEA	0.70	0.70	0.70	0.70	0.70	0.70	0.70	0.70	0.70
VHF FM XMITER	AN/ARC 114		1	3.00	1.00	24.00	28.50	MEA	3.00	3.00	1.50	0.42	3.00	1.50	0.42	3.00	1.50
SCRAMBLER	KY 28		1	2.00	15.00	24.00	28.50	SPEC	2.00	2.00	2.00	2.00	2.00	2.00	2.00	2.00	2.00
ADF RECEIVER	AN/ARN 89		1	1.40	15.00	24.00	28.50	MEA	1.40	1.40	1.40	1.40	1.40	1.40	1.40	1.40	1.40
VHF-AM RADIO	AN/ARC 115		1														
VHF AM RECEIVE	AN/ARC 115		1	0.62	15.00	24.00	28.50	MEA	0.62	0.62	0.62	0.62	0.62	0.62	0.62	0.62	0.62
VHF-AM XMITER	AN/ARC 115		2	1.79	1.00	24.00	28.50	MEA	1.79	0.89	0.25		1.79	0.89	0.25	1.79	0.89
INVERTER																	
STBY INVERTER	TYPE PU 543( 1/A		1		0.0	24.00	28.50	SPEC		0.0	0.0	0.0		0.0	0.0	0.0	0.0
STBY INV PWR RLY	MS2414CD1		1	0.31	0.0	24.00	28.50	SPEC	0.31	0.0	0.0	0.0	0.0	0.0	0.0	0.0	0.0
CHAFF DISPENSER	M-130		1	1.32	0.0	24.00	28.50	SPEC	1.32	0.0	0.0	0.0	1.32	0.50	0.01		
TOTAL NON-ESSENTIAL DC BUS										69.25	66.85	54.00	53.87	50.65	48.44		
TOTAL ESSENTIAL + NON-ESSENTIAL DC BUS										129.47	123.97	105.07	165.80	143.71	114.23		

209099-26-6



EQUIPMENT	PART DESIGNATION	NOTES	NO OF UNITS	AMPS PER UNIT	OPER TIME MIN	MIN VOLT	MAX VOLT	PWR SOR INF	CONN LOAD	OPERATING CONDITIONS							
										5 SEC			EMERGENCY				
										5 SEC	LAND 2 MIN	15 MIN	5 SEC	2 MIN	15 MIN		
ESSENTIAL DC BUS																	
FUEL CONTROL																	
FUEL BOOST PUMP	205 060 606		1	3.20	15.00	24.00	28.50	MEA	3.20		3.20	3.20	3.20		3.20	3.20	3.20
FUEL SOFF VALVE	204 062 520		1	2.00	0.02	18.00	29.00	MEA	2.00								
FUEL CONT VALVE	GW LIST CECO		1	1.30	15.00	24.00	28.50	SPEC	1.30		1.30	1.30	1.30		1.30	1.30	1.30
GOV RPM ACT	204 060 762		1	0.90	1.00	24.00	28.50	SPEC	0.90								
IDLE STOP SOL	GW LISK L 2540		1	4.60	0.03	24.00	28.50	SPEC	4.60		1.65	0.07	0.01		1.65	0.07	0.01
FUEL LOW RLY	GE 352791G200F 9	1	1	0.0	0.0	24.00	28.50	SPEC	0.0								
OIL BY PASS SOL	AV2381106B		1	2.00	0.05	24.00	28.50	SPEC	2.00								
OIL BY-PASS RLY	ALLIED MHB 60	1	1	0.11	0.0	24.00	28.50	SPEC	0.11								
RADIO NAV AND COMM																	
UHF AM RADIO	AN ARC 116		1														
UHF AM RECEIVE	AN/ARC 116		1	0.80	15.00	24.00	28.50	MEA	0.80		0.80	0.80	0.80		0.80	0.80	0.80
UHF AM XMITER	AN/ARC 116	2	1	3.00	1.00	24.00	28.50	MEA	3.00		3.00	1.50	0.42		3.00	1.50	0.42
INTERCOM SYS	C6533 ARC		2	0.07	15.00	24.00	28.50	MEA	0.14		0.14	0.14	0.14		0.14	0.14	0.14
VOR LOC GS MB	AN ARN 123		1	0.39	15.00	24.00	28.50	SPEC	0.39		0.39	0.39	0.39		0.39	0.39	0.39
RADAR																	
IFF TRANSPONDER	AN APX 72		1	3.80	15.00	21.00	29.00	MEA	3.80		3.80	3.80	3.80		3.80	3.80	3.80
TEST SET	TS 1843 APX	8	1	0.70	15.00	21.00	29.00	MEA	0.70		0.70	0.70	0.70		0.70	0.70	0.70
COMPUTER KIT	TA TSEC MARK XII	8	1	1.10	15.00	24.00	28.50	SPEC	1.10		1.10	1.10	1.10		1.10	1.10	1.10
RADAR ALTIMETER	AN APN 209		1	2.00	15.00	24.00	28.50	SPEC	2.00		2.00	2.00	2.00		2.00	2.00	2.00
RADAR WARNING	AN/APR 39		1	1.10	15.00	24.00	28.50	SPEC	1.10		1.10	1.10	1.10		1.10	1.10	1.10
PROX WARNING	YG 1054		1	1.50	15.00	24.00	28.50	SPEC	1.50		1.50	1.50	1.50		1.50	1.50	1.50
INVERTER																	
MAIN INVERTER	209 075 572		1		15.00	24.00	28.50	SPEC			8.84	8.84	8.84		8.84	8.84	8.84
ADDTL TOW MAIN	209 075 572		1		15.00	24.00	28.50	SPEC									
MAIN INV PWR RLY	MS24140D2		1	0.36	15.00	24.00	28.50	SPEC	0.36		0.36	0.36	0.36		0.36	0.36	0.36
AC PWR CONT RLY	110 128 1		1	0.11	15.00	24.00	28.50	SPEC	0.11		0.11	0.11	0.11		0.11	0.11	0.11
INV SELECT RLY	110 111 1		1	0.20	15.00	24.00	28.50	SPEC	0.20		0.20	0.20	0.20		0.20	0.20	0.20
WARNING AND EMERGENCY																	
CAUT LT PANEL	204 075 705		1	0.20	15.00	24.00	28.50	SPEC	0.20		0.20	0.20	0.20		0.20	0.20	0.20
RPM LIMIT WARN	205 074 001		1	0.30	15.00	24.00	28.50	SPEC	0.30		0.30	0.30	0.30		0.30	0.30	0.30
FIRE DETECTION	209 075 395		1	0.07	15.00	24.00	28.50	MEA	0.07		0.07	0.07	0.07		0.07	0.07	0.07
RPM WARN LIMIT	209 075 326		1	0.98	15.00	24.00	28.50	MEA	0.98		0.98	0.98	0.98		0.98	0.98	0.98
MAST CAUT SYS	209 075 325		1	0.20	15.00	21.00	29.00	MEA	0.20		0.20	0.20	0.20		0.20	0.20	0.20
TOTAL ESSENTIAL DC BUS											53.99	50.57	49.08		50.50	47.16	45.84



EQUIPMENT	PART DESIGNATION	NOTES	NO OF UNITS	AMPS PER UNIT	OPER TIME MIN	MIN VOLT	MAX VOLT	PWR SOR INF	CONN LOAD	OPERATING CONDITIONS							
										5 SEC	LAND 2 MIN	15 MIN	5 SEC	2 MIN	15 MIN		
NON ESSENTIAL DC BUS																	
FLIGHT INSTRUMENTS																	
PITOT HEATER	AN6813 1		1	3.75	15 00	24 00	28 50	SPEC	3.75		3.75	3.75	3.75				
HEATING																	
ECU	209 070 403		1	0.30	15 00	24 00	28 50	SPEC	0.30		0.30	0.30	0.30				
BLEED AIR SOL	397580 1 1		1	0.80	15 00	24 00	28 50	SPEC	0.80		0.80	0.80	0.80				
RAIN REMOV SOL	JANITROL 43070		1	0.64	15 00	24 00	28 50	SPEC	0.64		0.64	0.64	0.64				
HTR CONT RELAY	MS24149D1		1	0.20	0 0	24 00	28 50	SPEC	0.20								
TOW BLOWER	209 073 115		1	28.00	15 00	24 00	28 50	SPEC	28.00		28.00	28.00	28.00				
TOW BLOWER RLY	MS24181D1		1	0.40	15 00	24 00	28 50	SPEC	0.40		0.40	0.40	0.40				
LIGHTING																	
SIDE POSITI LTS	AN3033 12 13		2	0.80	15 00	24 00	28 50	SPEC	1.60		1.60	1.60	1.60				
SEARCH LIGHT	FSN6620 283 976 7		1	16.70	5 00	24 00	28 50	SPEC	16.70		16.70	16.70	5.57				
ANTICOLLISION LT	MIL L 98085		1	2.15	15 00	24 00	28 50	SPEC	2.15		2.15	2.15	2.15				
TAIL POSITION LT	GR30 0003 15 1683		2	0.90	15 00	24 00	28 50	SPEC	1.80		1.80	1.80	1.80				
POS LTS FLASHER	MS24577 2		1	0.40	15 00	21 00	29 00	MEA	0.40		0.40	0.40	0.40				
FUEL CONTROL																	
FUEL BOOST PUMP	205 060 606		1	3.20	15 00	24 00	28 50	MEA	3.20		3.20	3.20	3.20				
RADIO NAV & COMM																	
VHF FM RADIO	AN ARC 114		1														
VHF FM RECEIVER	AN ARC 114		1	0.70	15 00	24 00	28 50	MEA	0.70		0.70	0.70	0.70				
VHF FM XMITER	AN ARC 114		1	3.00	1 00	24 00	28 50	MEA	3.00		3.00	1.50	0.42				
SCRAMBLER	KY 28		1	2.00	15 00	24 00	28 50	SPEC	2.00		2.00	2.00	2.00				
ADF RECEIVER	AN ARN 89		1	1.40	15 00	24 00	28 50	MEA	1.40		1.40	1.40	1.40				
VHF AM RADIO	AN ARC 115		1														
VHF AM RECEIVE	AN ARC 115		1	0.62	15 00	24 00	28 50	MEA	0.62		0.62	0.62	0.62				
VHF AM XMITER	AN ARC 115		1	1.79	1 00	24 00	28 50	MFA	1.79		1.79	0.89	0.25				
INVERTER																	
STBY INVERTER	TYPE PU 543( ) A		1		0 0	24 00	28 50	SPEC			0 0	0 0	0 0				
STBY INV PWR RLY	MS24140D1		1	0.31	0 0	24 00	28 50	SPEC	0.31		0 0	0 0	0 0				
CHAFF DISPENSER	M 130		1	1.32	0 0	24 00	28 50	SPEC	1.32		0 0	0 0	0 0				
TOTAL NON ESSENTIAL DC BUS											69.25	66.85	54.00				
TOTAL ESSENTIAL + NON ESSENTIAL DC BUS											123.24	117.43	103.08	50.50	47.16	45.84	

NOTES

- 1 THIS EQUIPMENT IS NORMALLY DE ENERGIZED
- 2 ONE MINUTE OPERATION OUT OF EACH TEN MINUTES
- 3 ENERGIZED EXCEPT DURING DE ICING
- 4 BATTERY LOAD DURING STARTING
- 5 BATTERY CHARGING VALUES CALCULATED
- 6 BATTERY IS REMOVED FROM MAIN DC BUS DURING FIRING TO SUPPLY GUN DRIVE POWER
- 7 SEVERAL WING STORES CONFIGURATIONS ARE POSSIBLE THIS ANALYSIS IS BASED ON THE CONFIGURATION RESULTING IN THE HIGHEST DC LOAD THAT IS 2XM 18 MINI GUNS ON INBOARD STATIONS AND FOUR TOW MISSILES AT EACH OUTBOARD STATION
- 8 PROVISIONS ONLY

209099-21-9

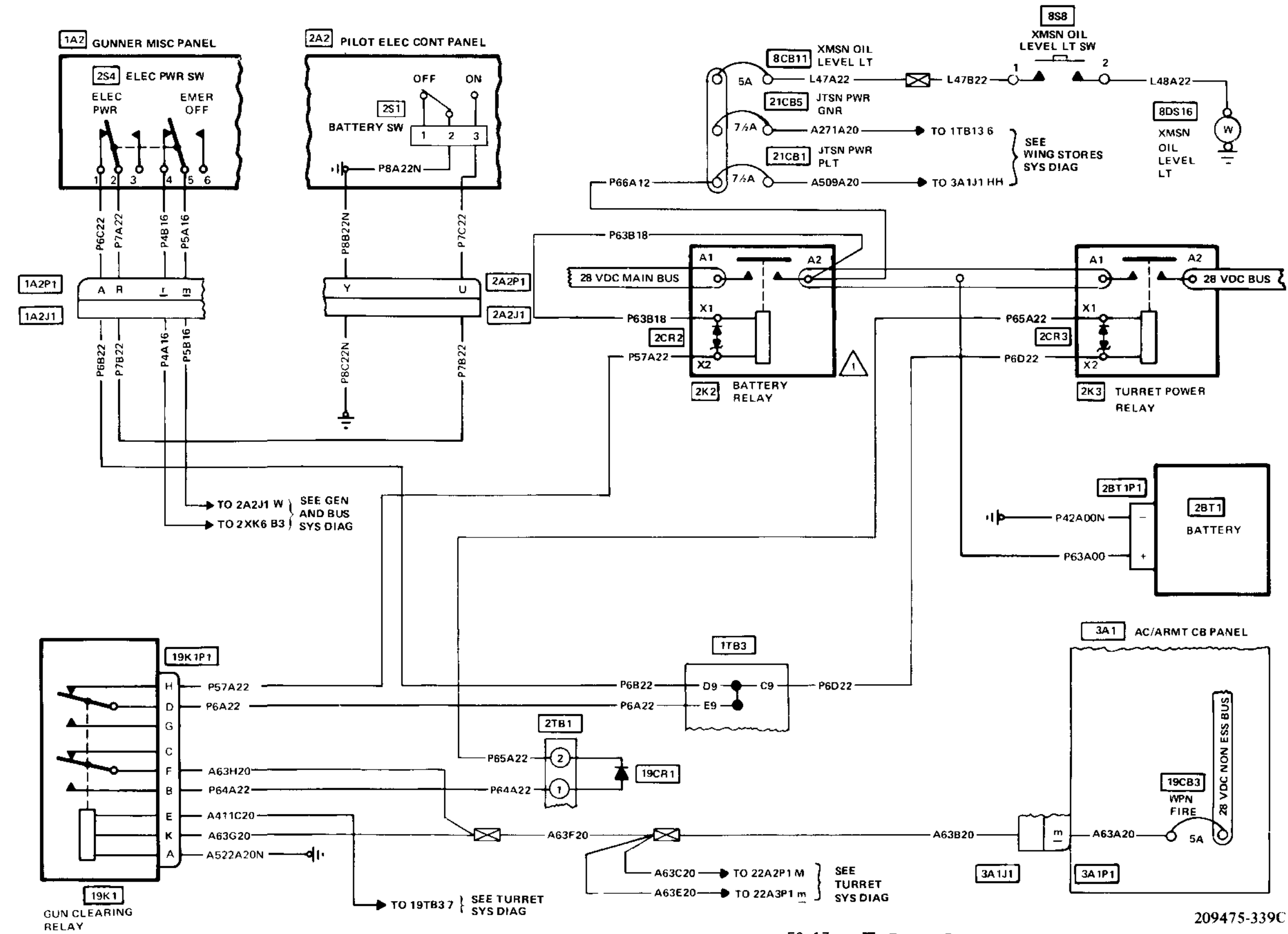

FO-17 P Battery System

209475-339C

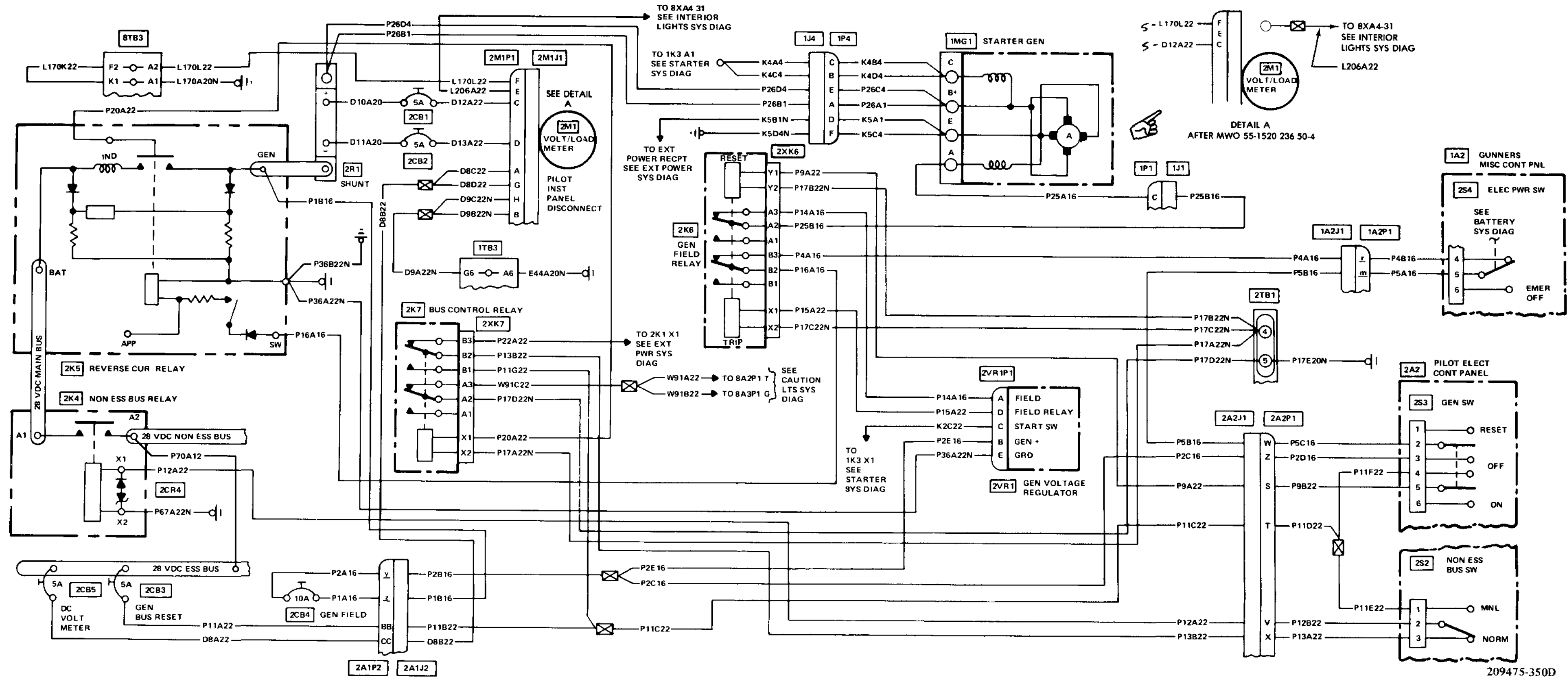

209475-350D

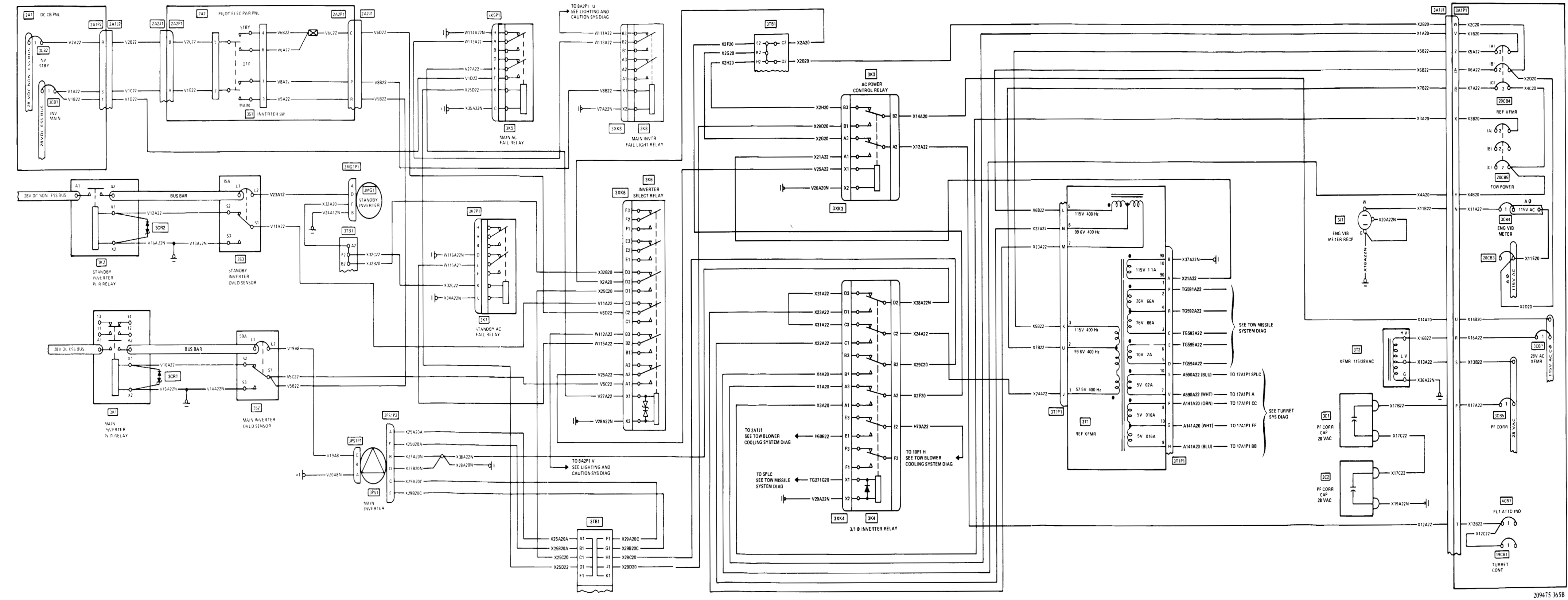

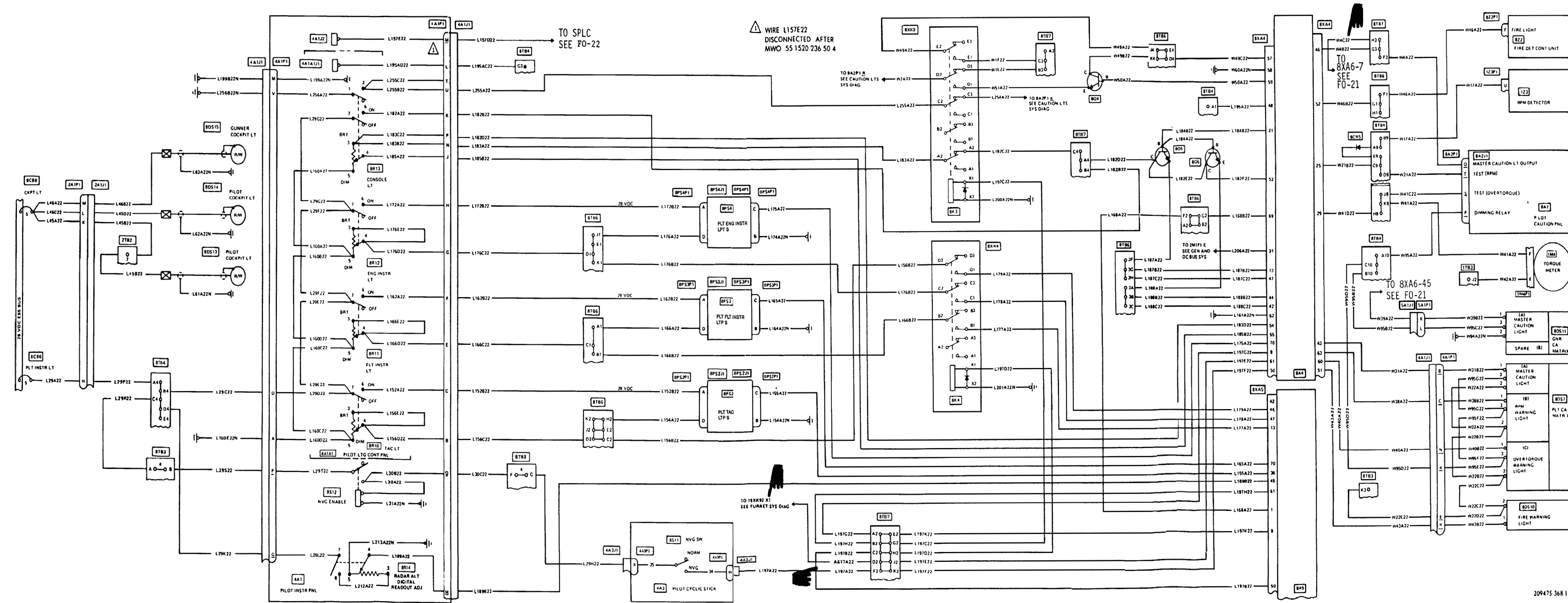

FO-20 Interior Lights System

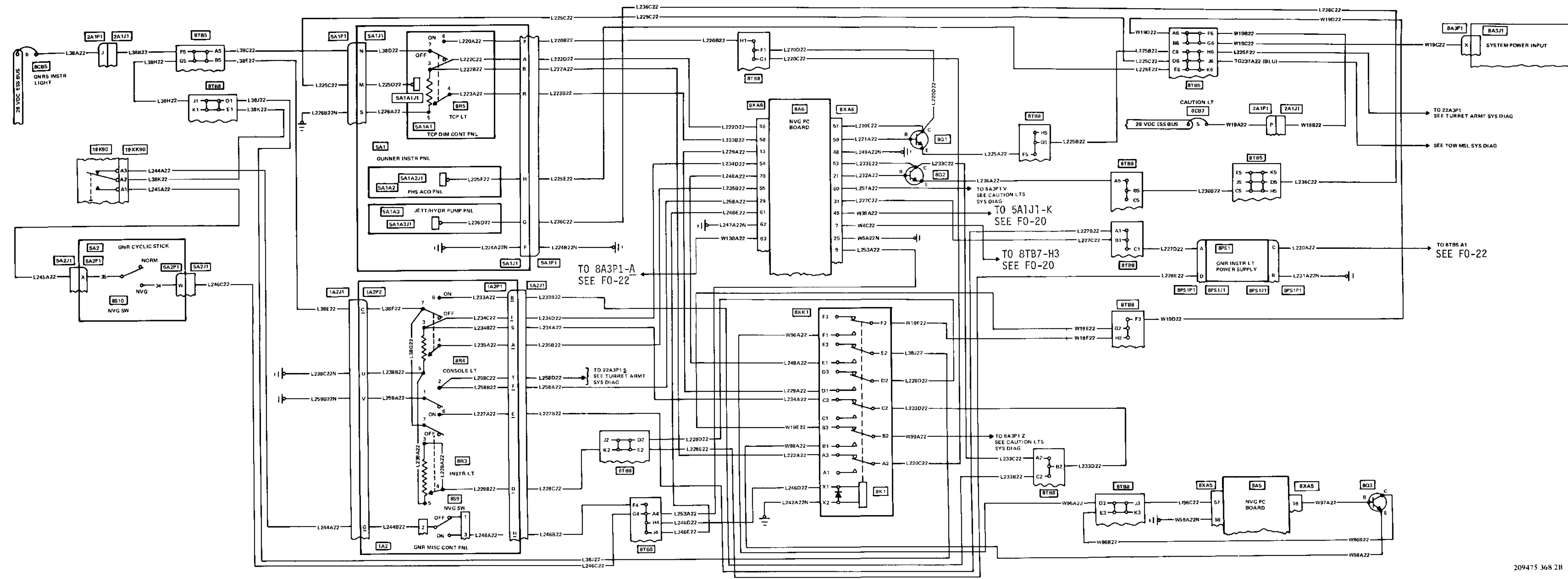

FO-21 Interior Lights System

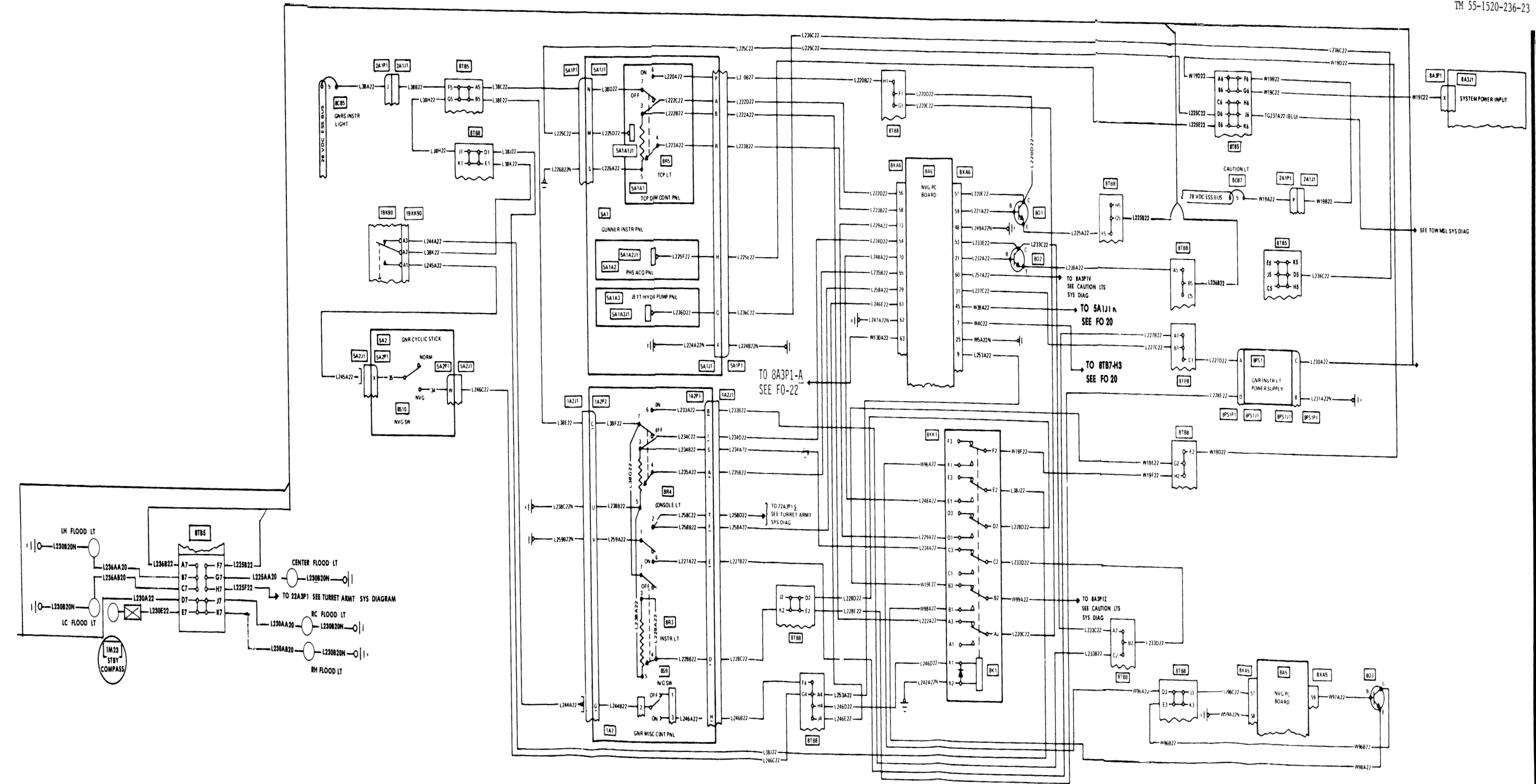

FO-21.1 Interior Lights System (After GWO 55-1520-236-50-4)

20475 50-28

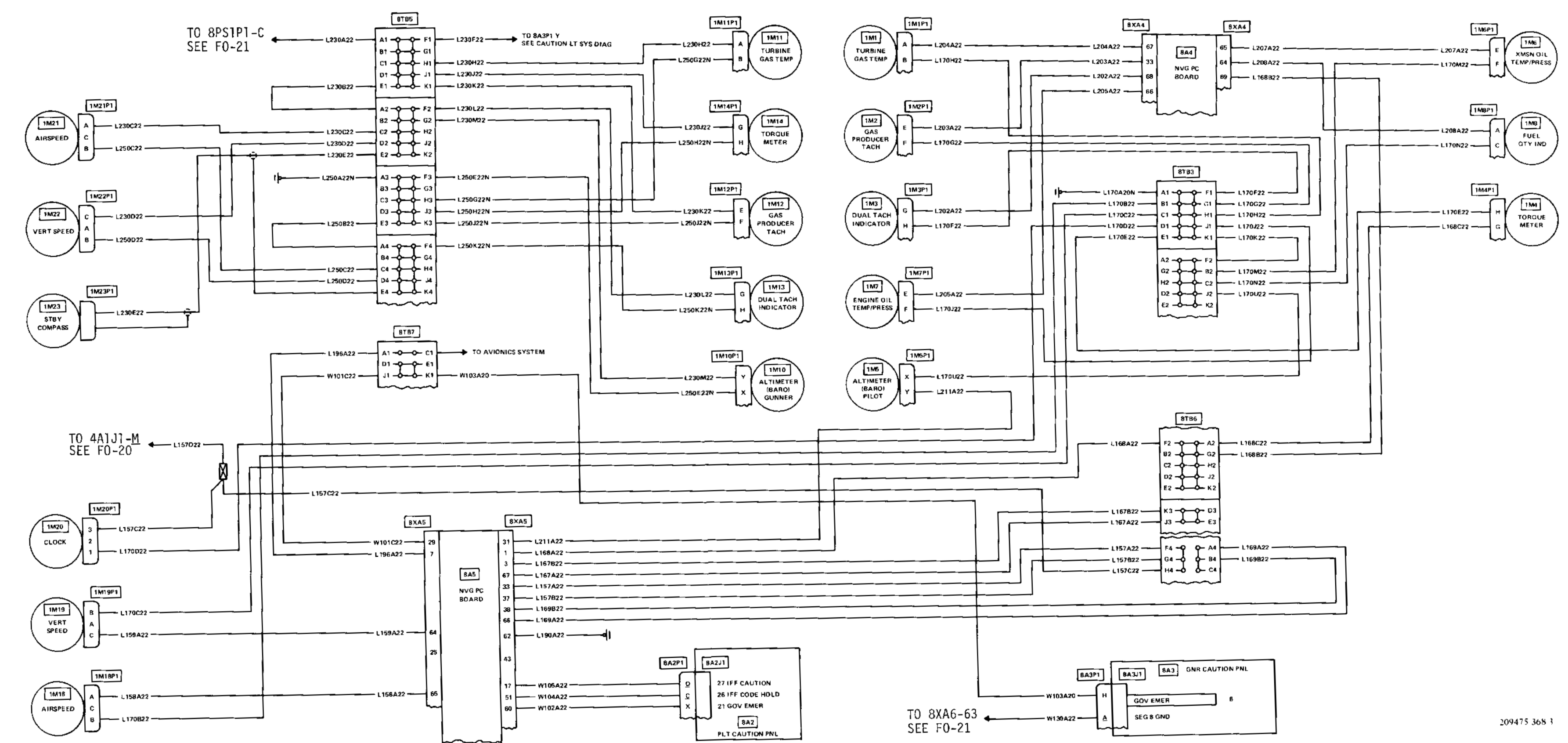

F0-22 Interior Lights System



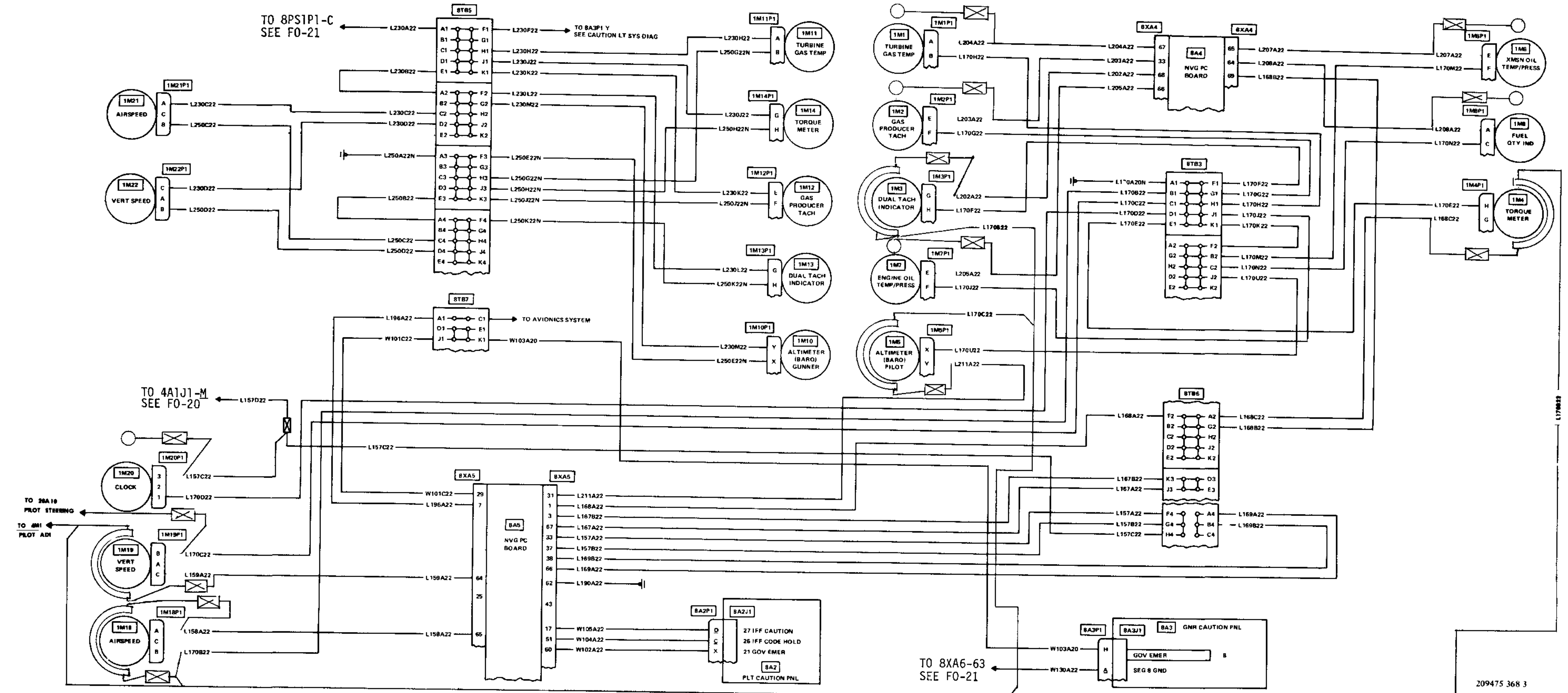

209475 368 3

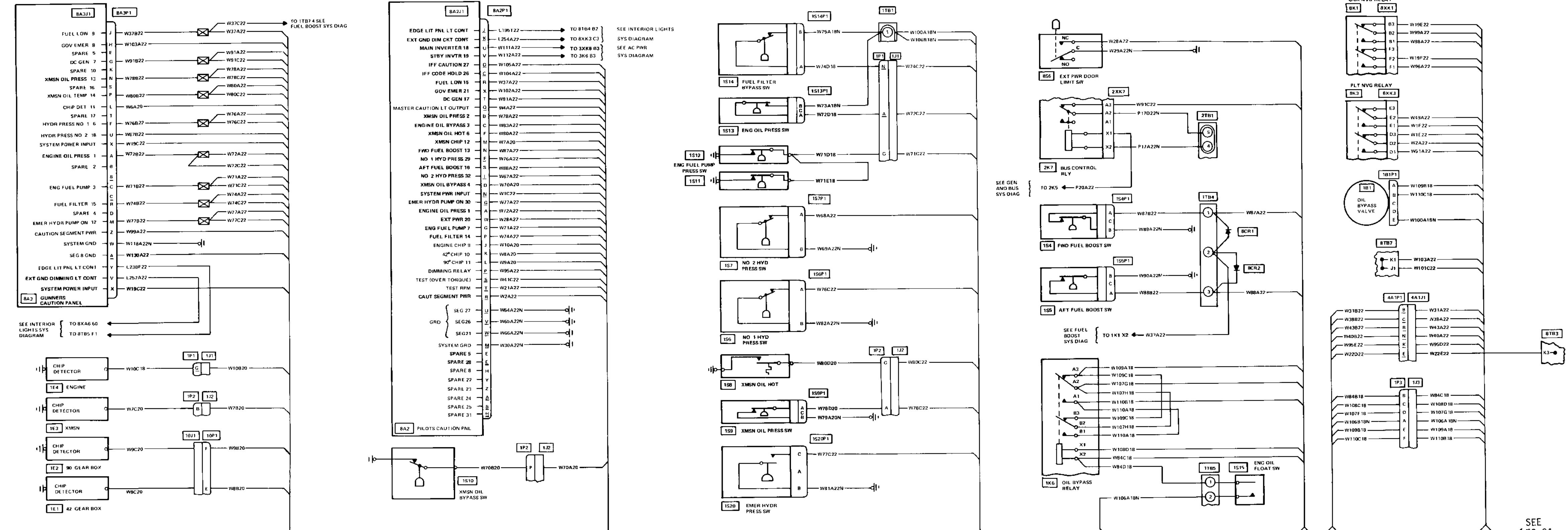

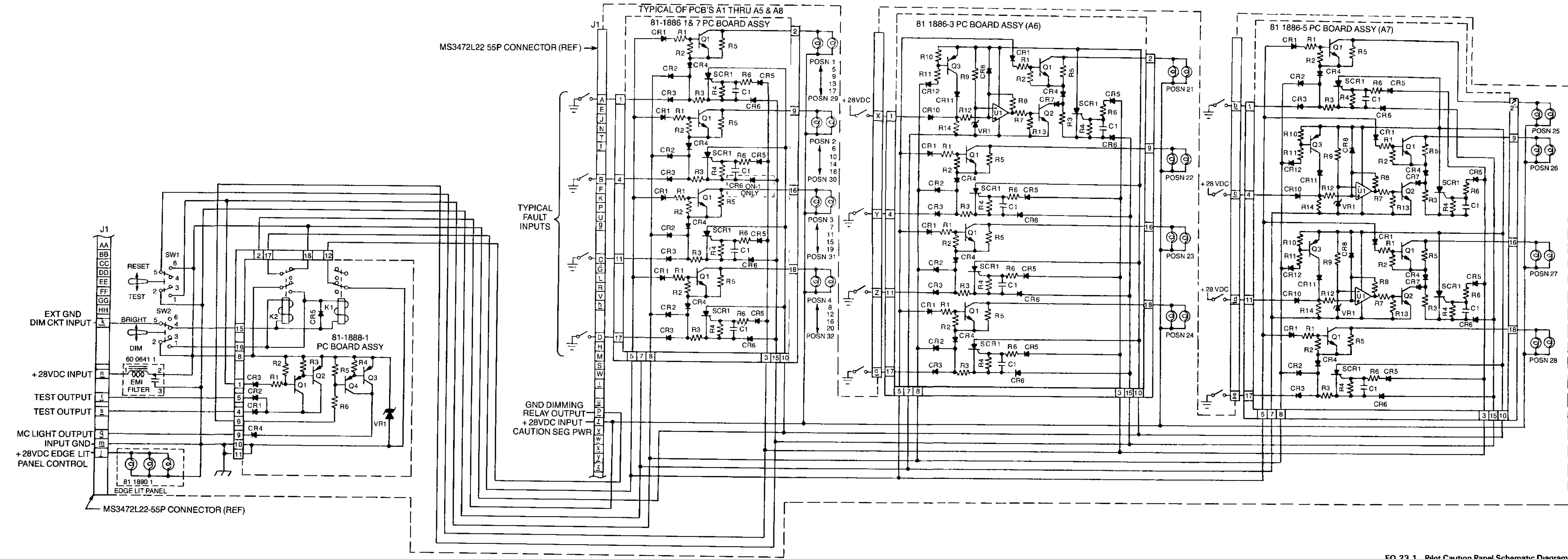

FO 23 1 Pilot Caution Panel Schematic Diagram

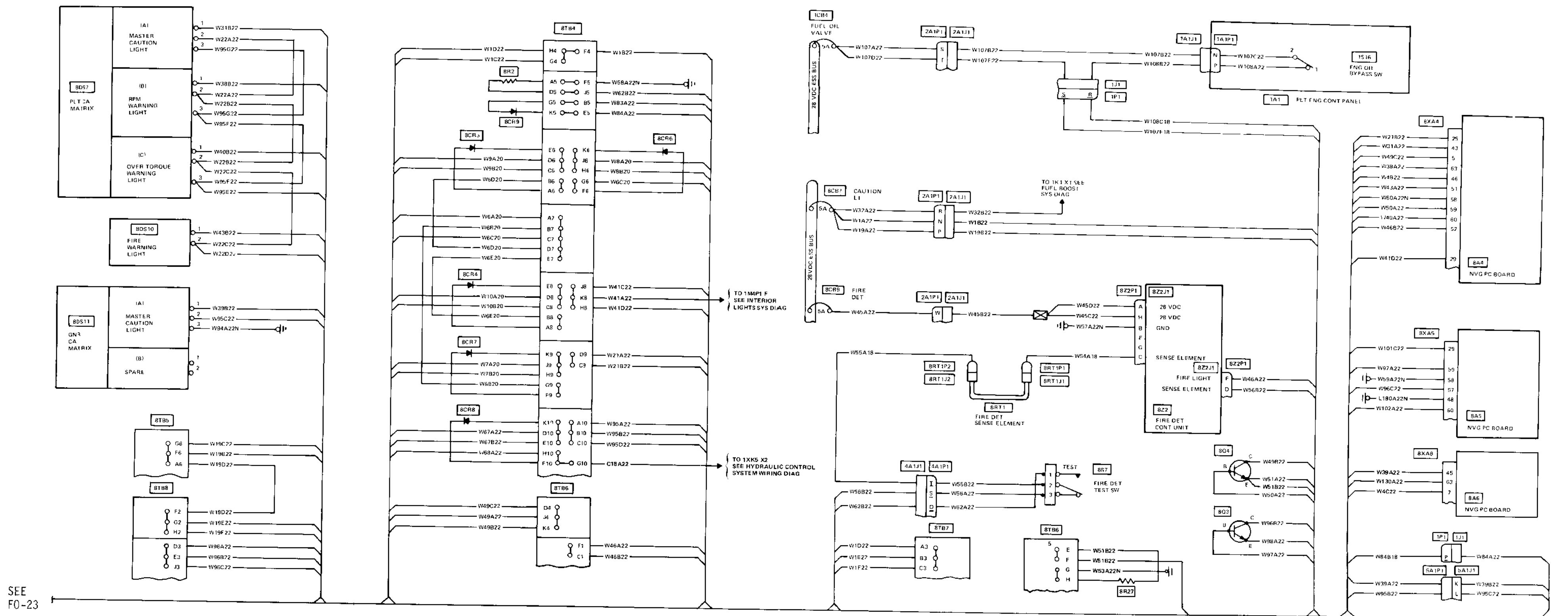

SEE FO-23

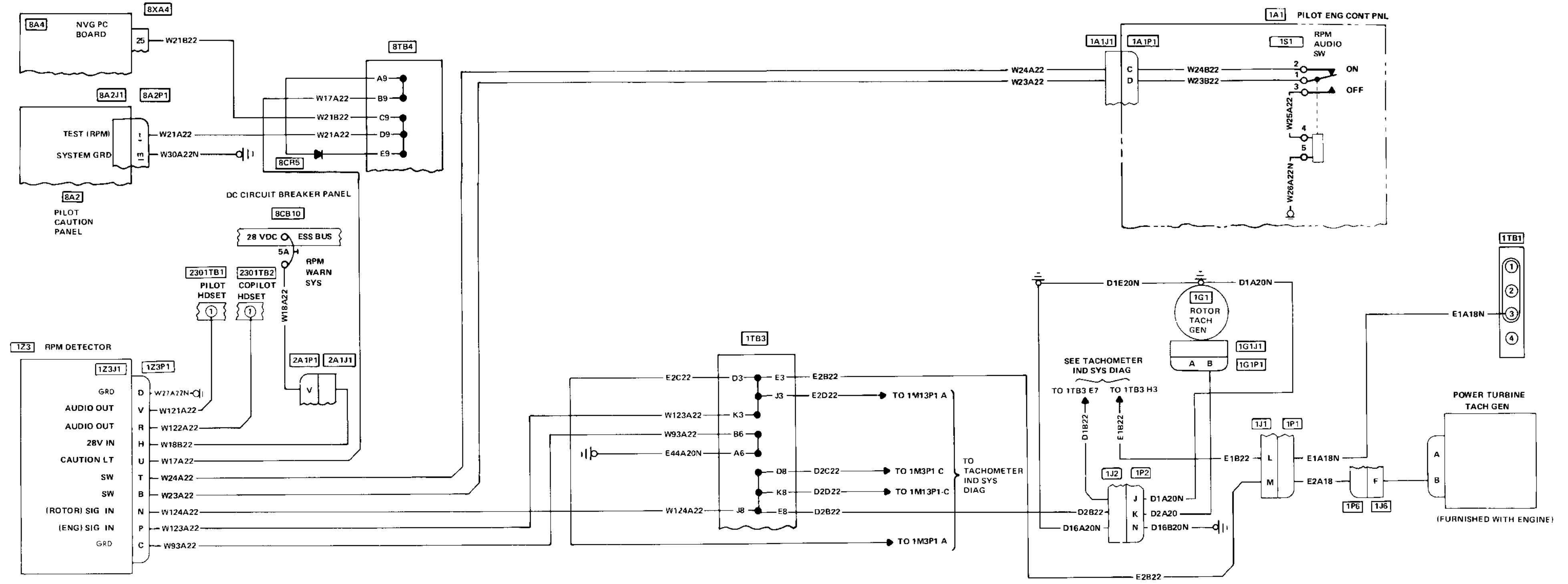

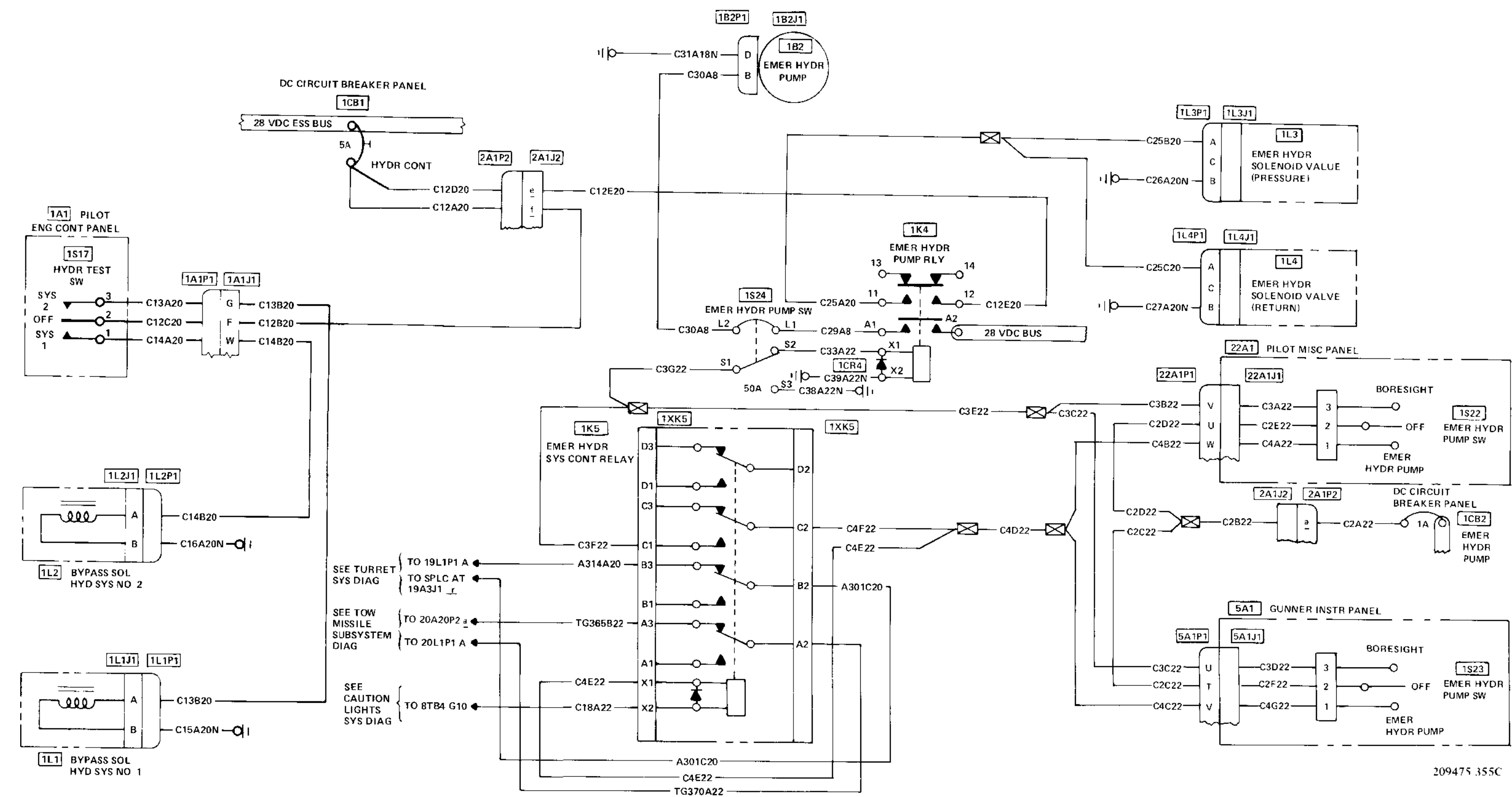

209475 355C

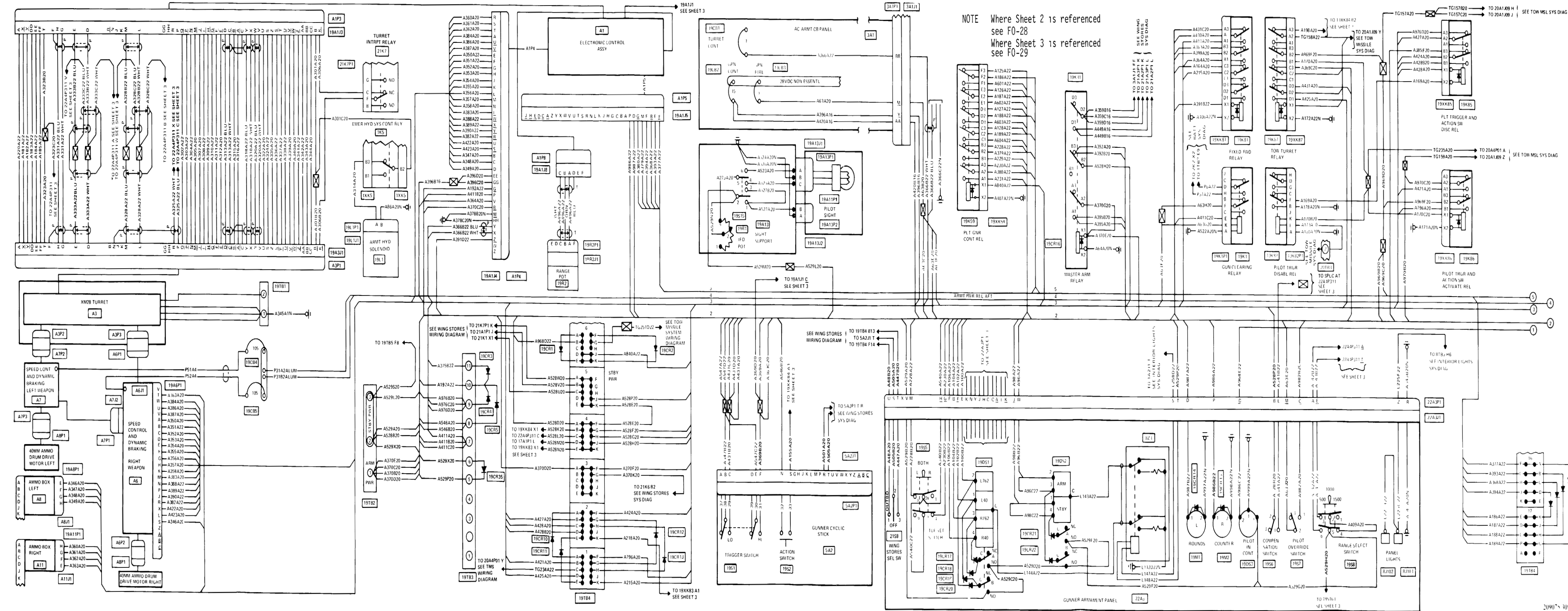

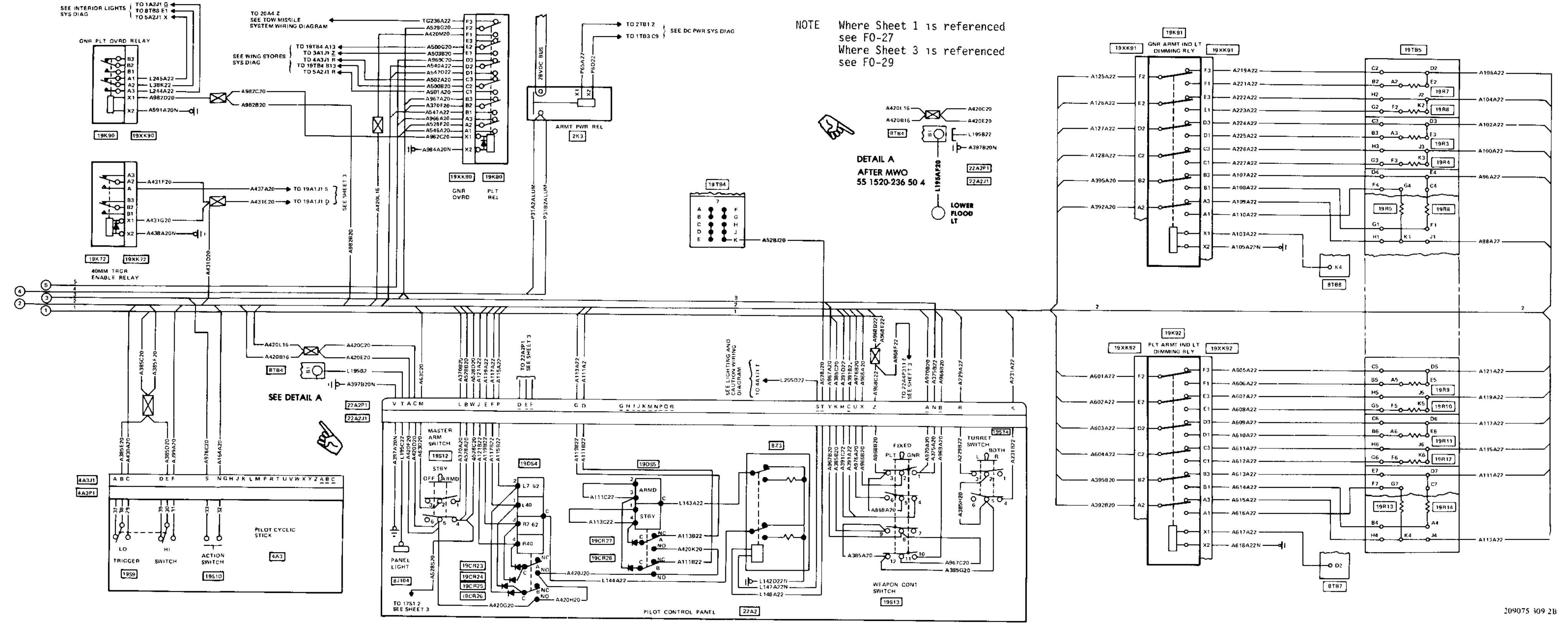



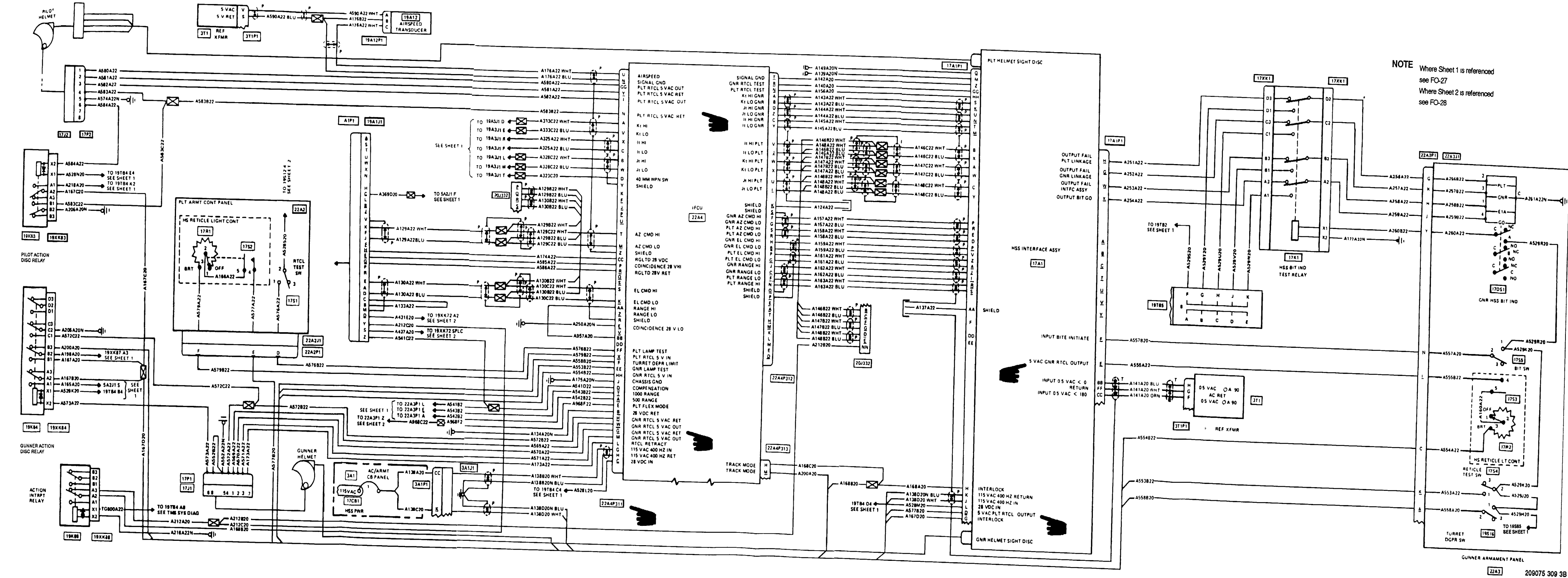

NOTE  
 Where Sheet 1 is referenced  
 see FO-27  
 Where Sheet 2 is referenced  
 see FO-28

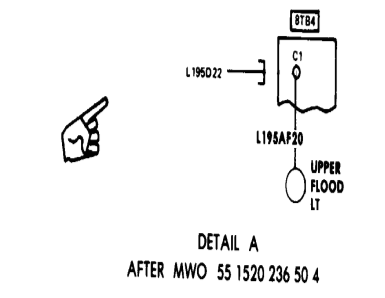

DETAIL A  
AFTER MW 55 1520 236 50 4

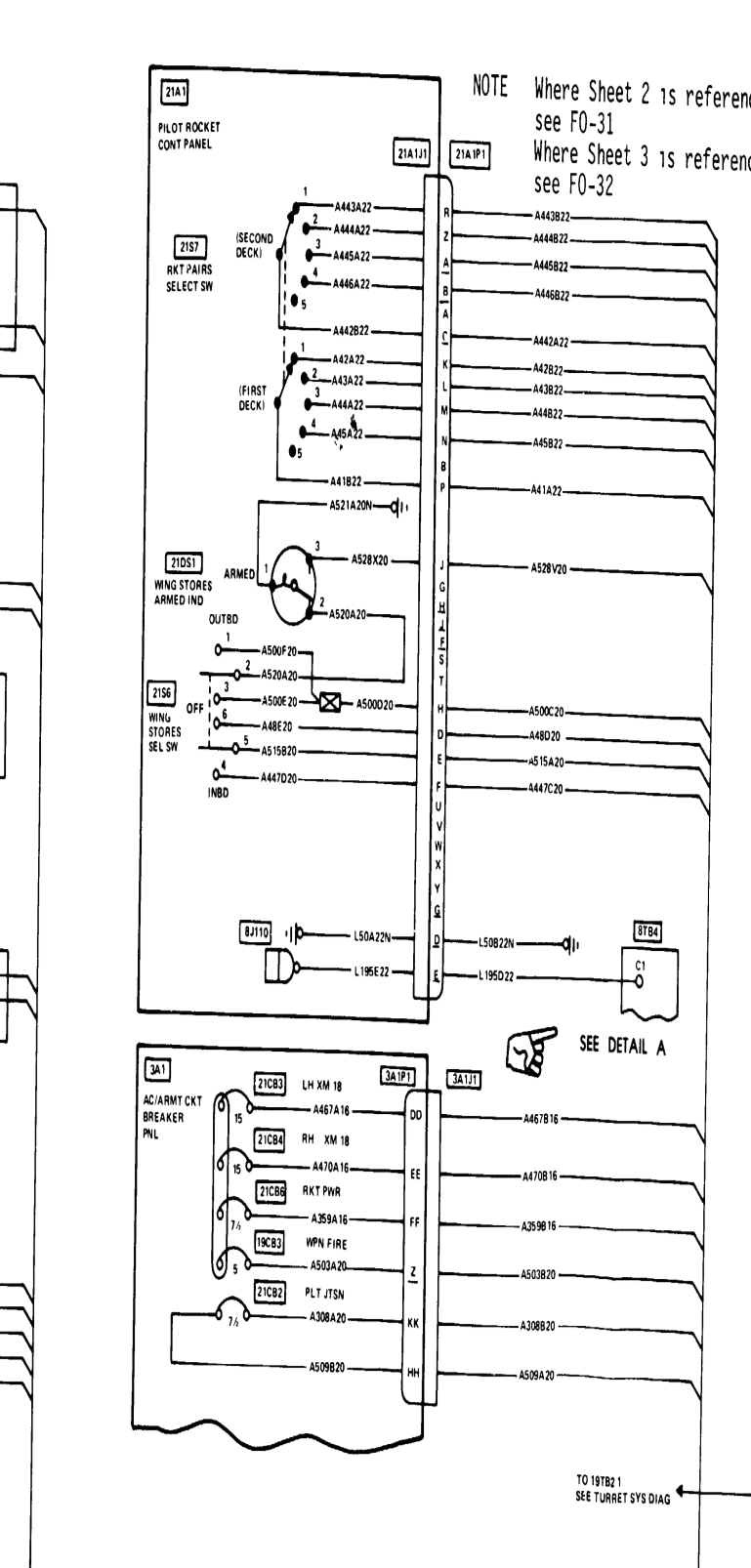
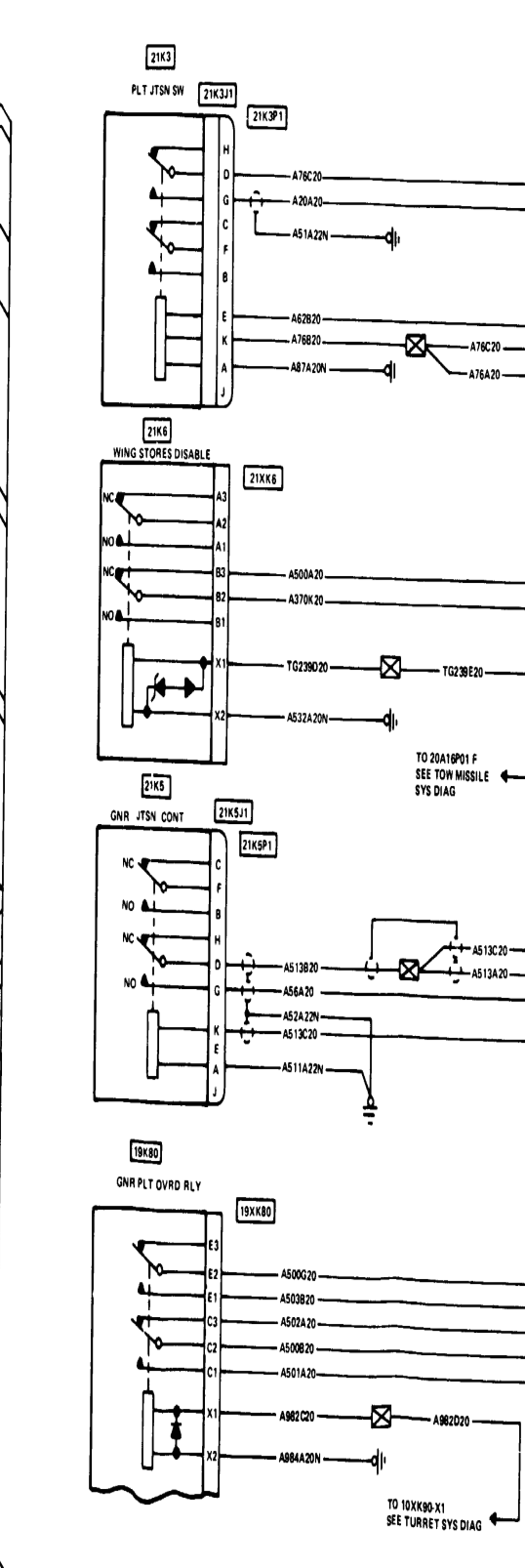
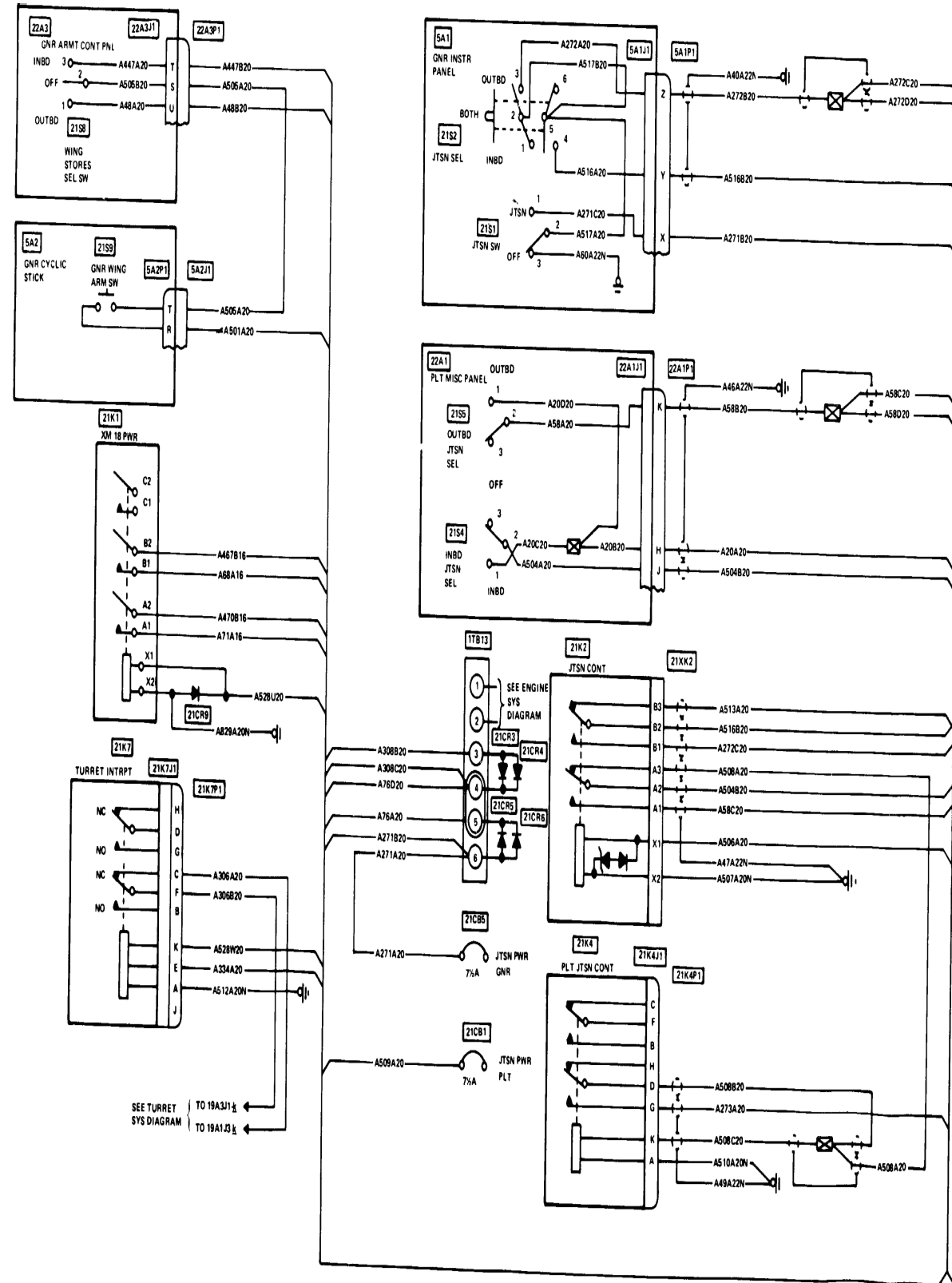

NOTE  
Where Sheet 2 is referenced see FO-31  
Where Sheet 3 is referenced see FO-32

SEE DETAIL A

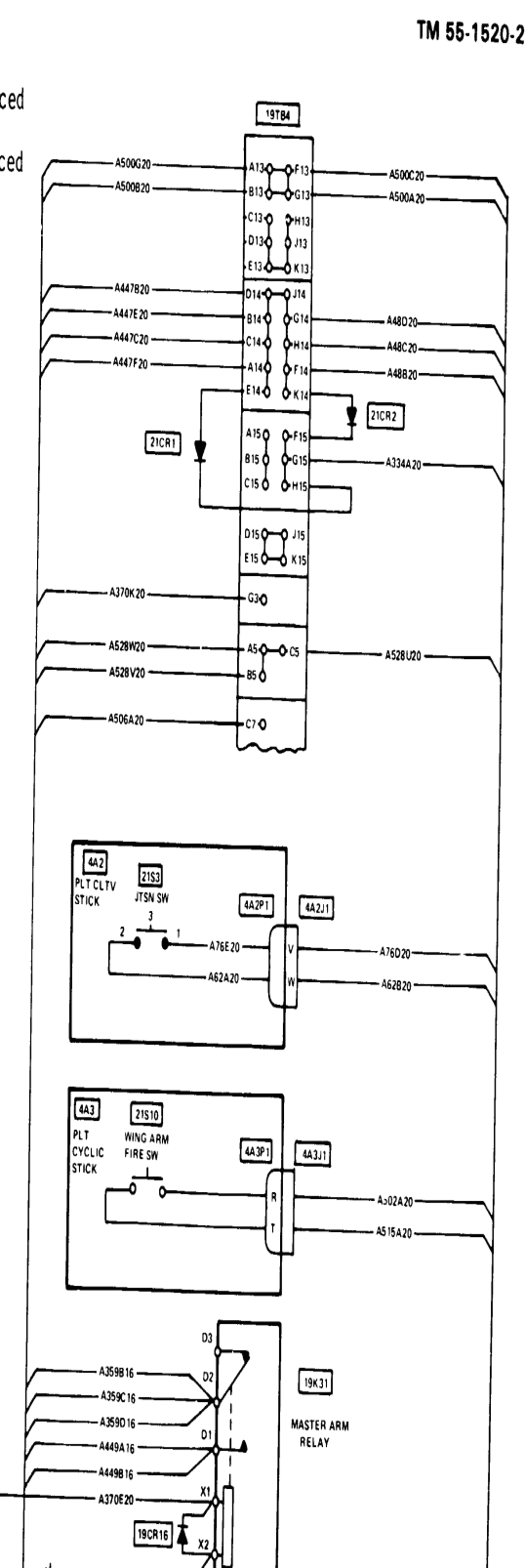

TO 19182-1  
SEE TURNET SYS DIAG

SEE TURNET SYS DIAG  
TO 19A11-1  
TO 19A12-1

TO 19182-1  
SEE TURNET SYS DIAG

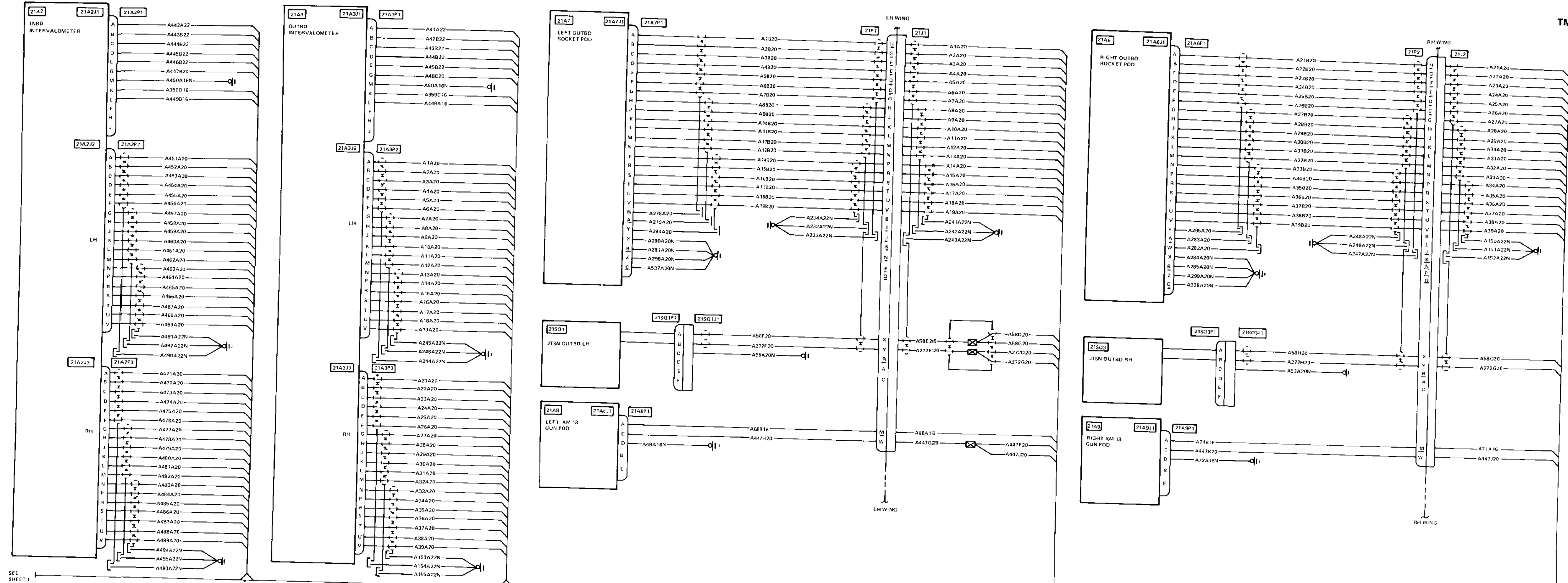

NOTE Where Sheet 1 is referenced see F0-30  
 Where sheet 3 is referenced see F0-32

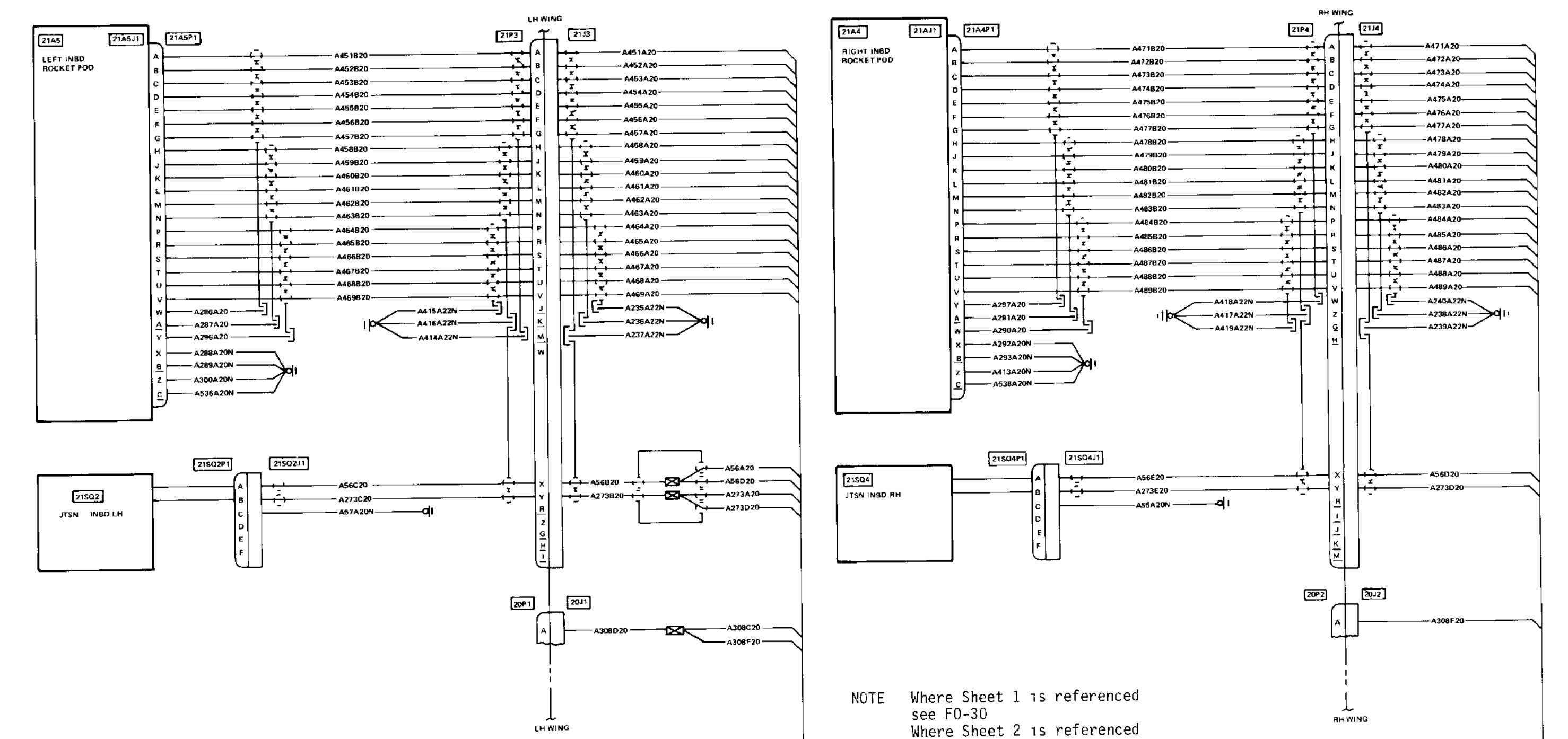

NOTE Where Sheet 1 is referenced see F0-30  
Where Sheet 2 is referenced see F0-31

SEE SHEET 2

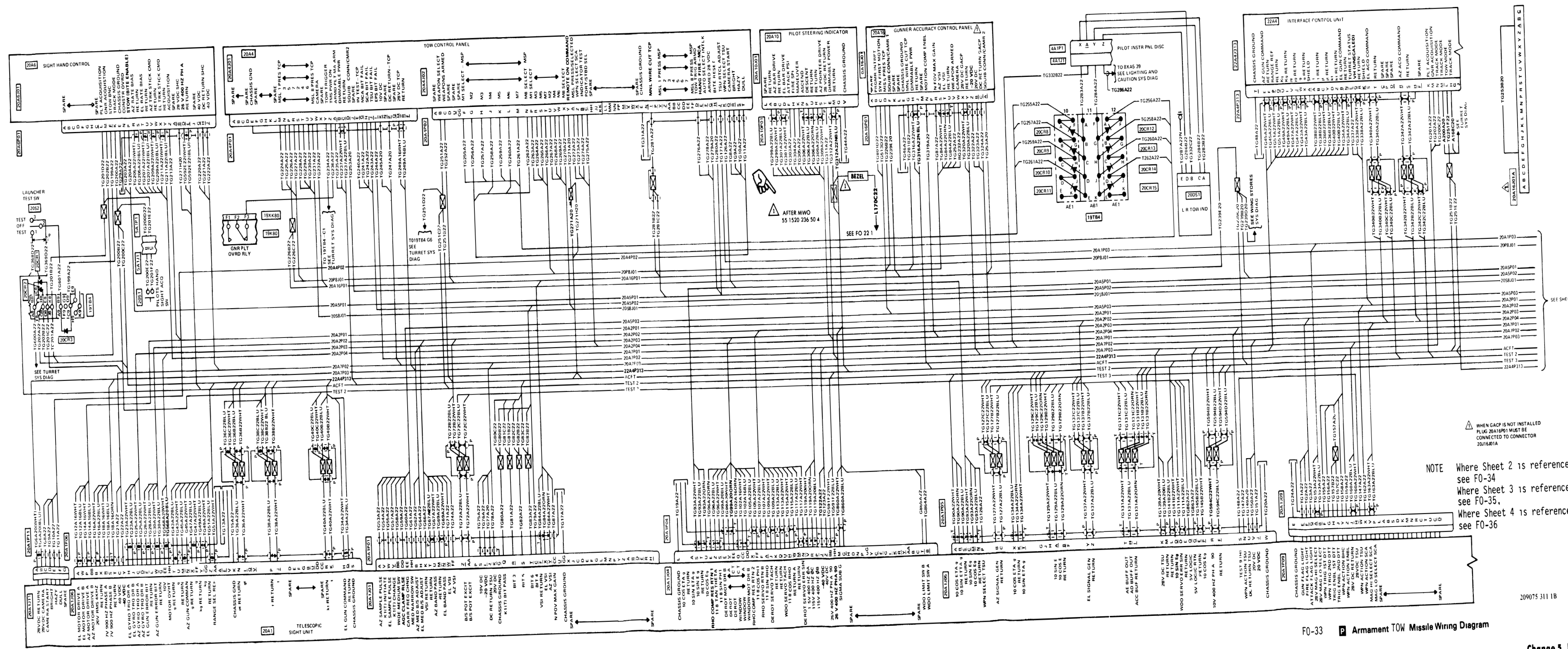

NOTE: WHEN GAOP IS NOT INSTALLED PLUG 2041901 MUST BE CONNECTED TO CONNECTOR 2051801A

Where Sheet 2 is referenced see FO-34  
 Where Sheet 3 is referenced see FO-35.  
 Where Sheet 4 is referenced see FO-36

209075 311 1B

FO-33 Armament TOW Missile Wiring Diagram

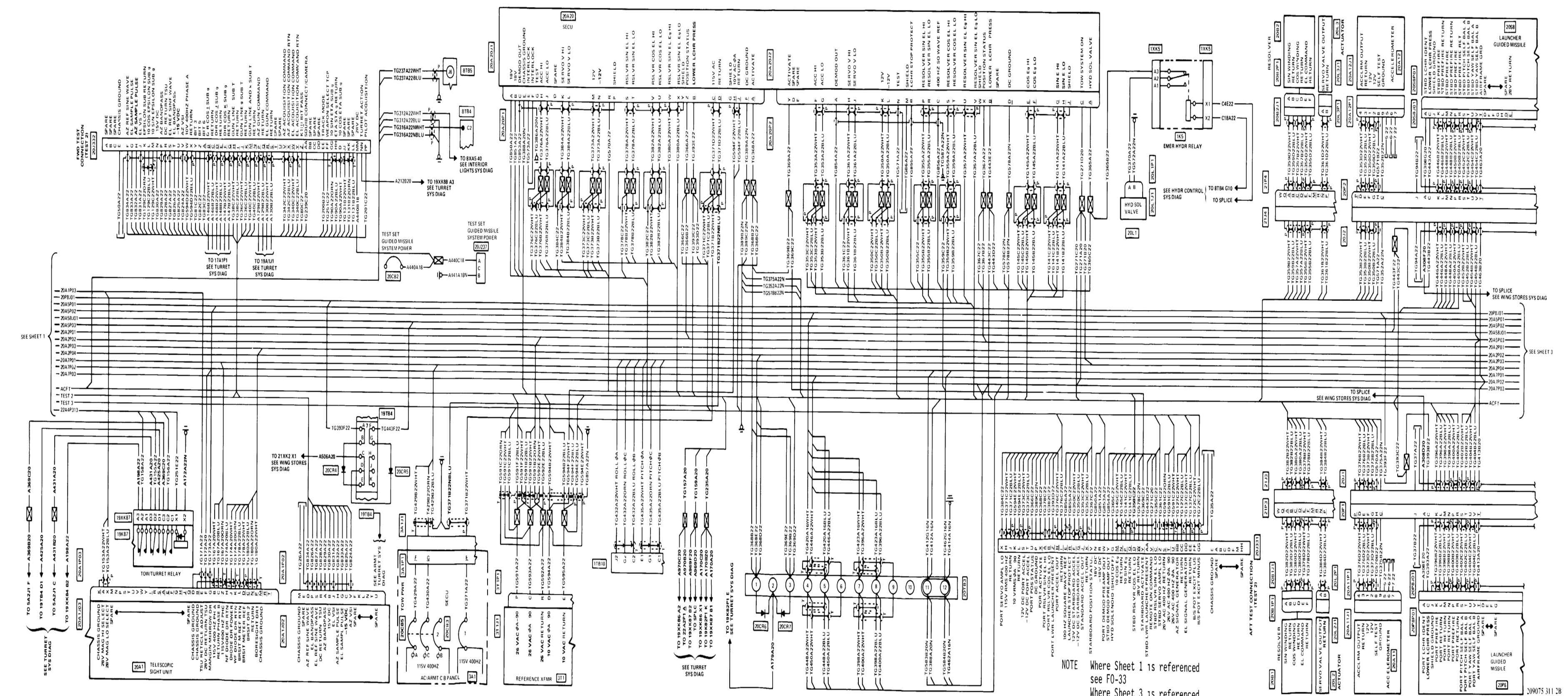

NOTE Where Sheet 1 is referenced see FO-33  
 Where Sheet 3 is referenced see FO-35  
 Where Sheet 4 is referenced see FO-36

FO-34 Armament TOW Missile Wiring Diagram

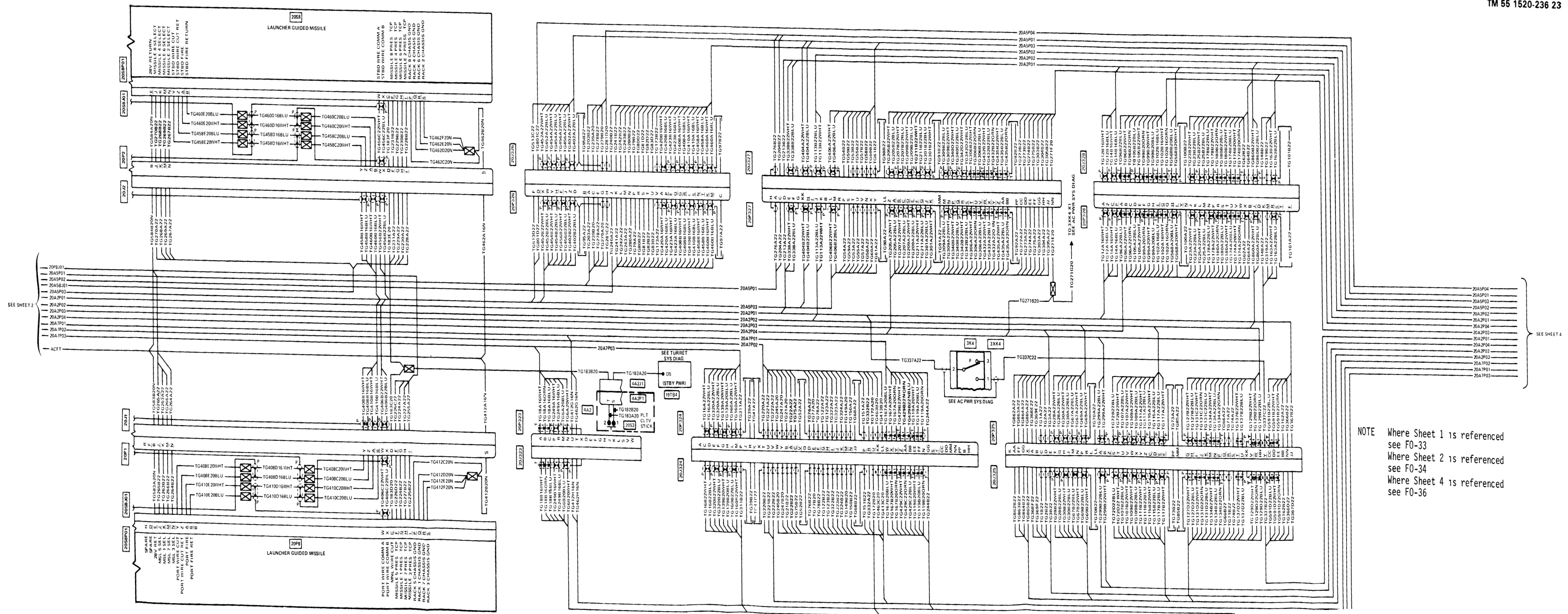

NOTE Where Sheet 1 is referenced see F0-33  
 Where Sheet 2 is referenced see F0-34  
 Where Sheet 4 is referenced see F0-36

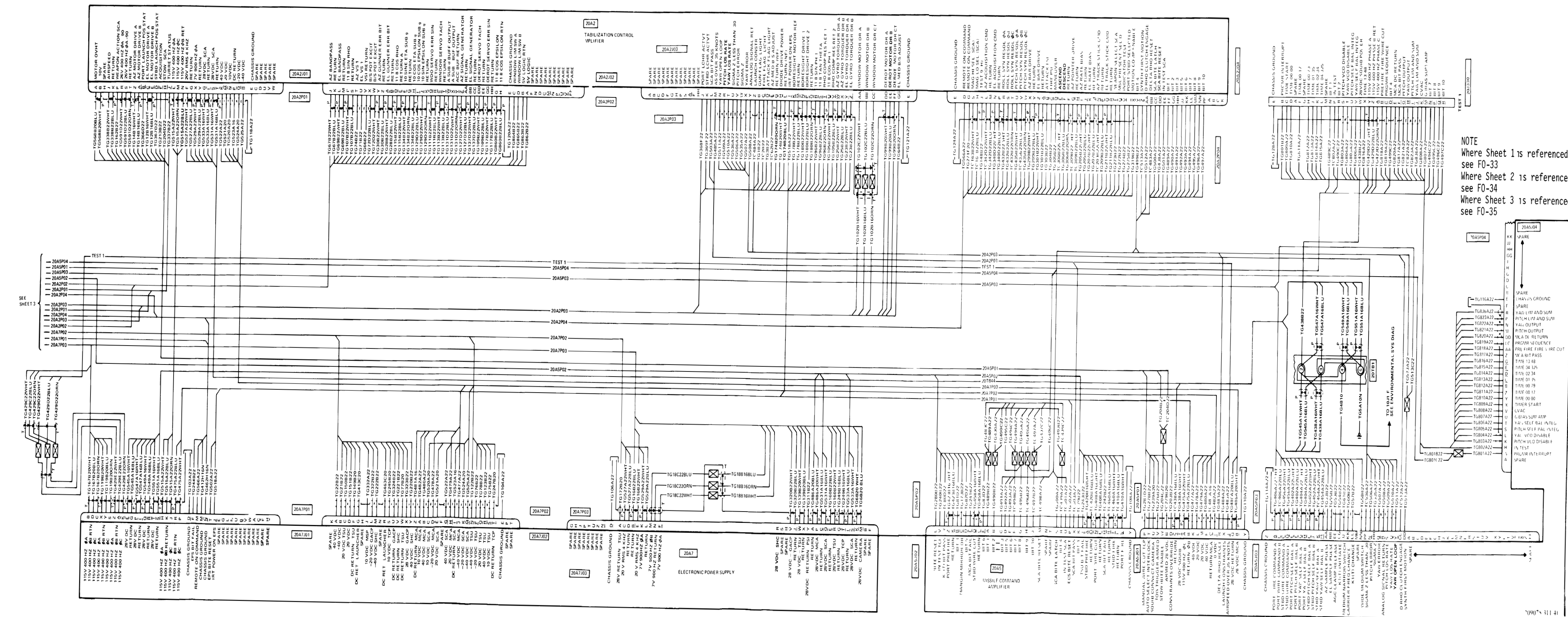

NOTE  
 Where Sheet 1 is referenced  
 see FO-33  
 Where Sheet 2 is referenced  
 see FO-34  
 Where Sheet 3 is referenced  
 see FO-35



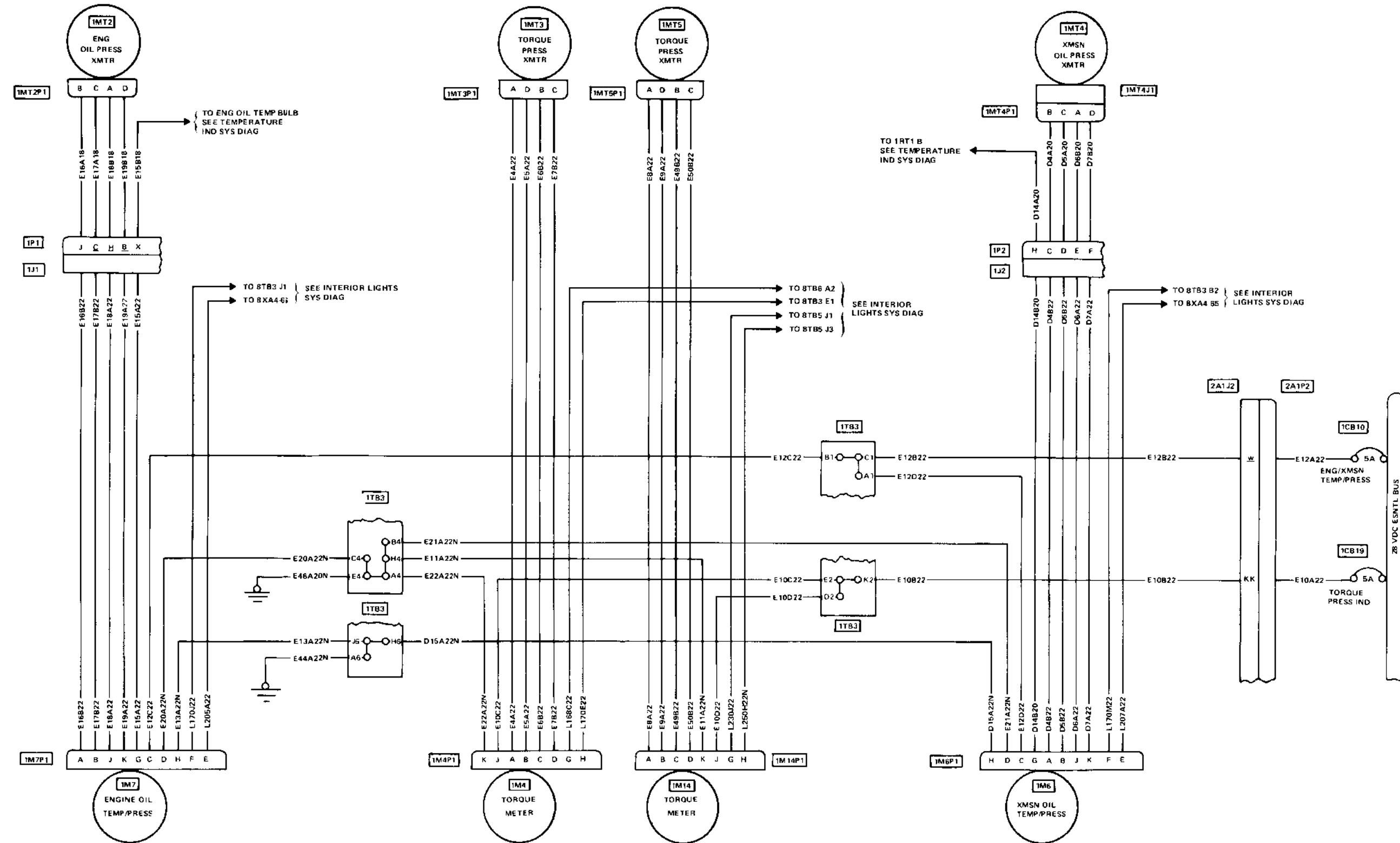

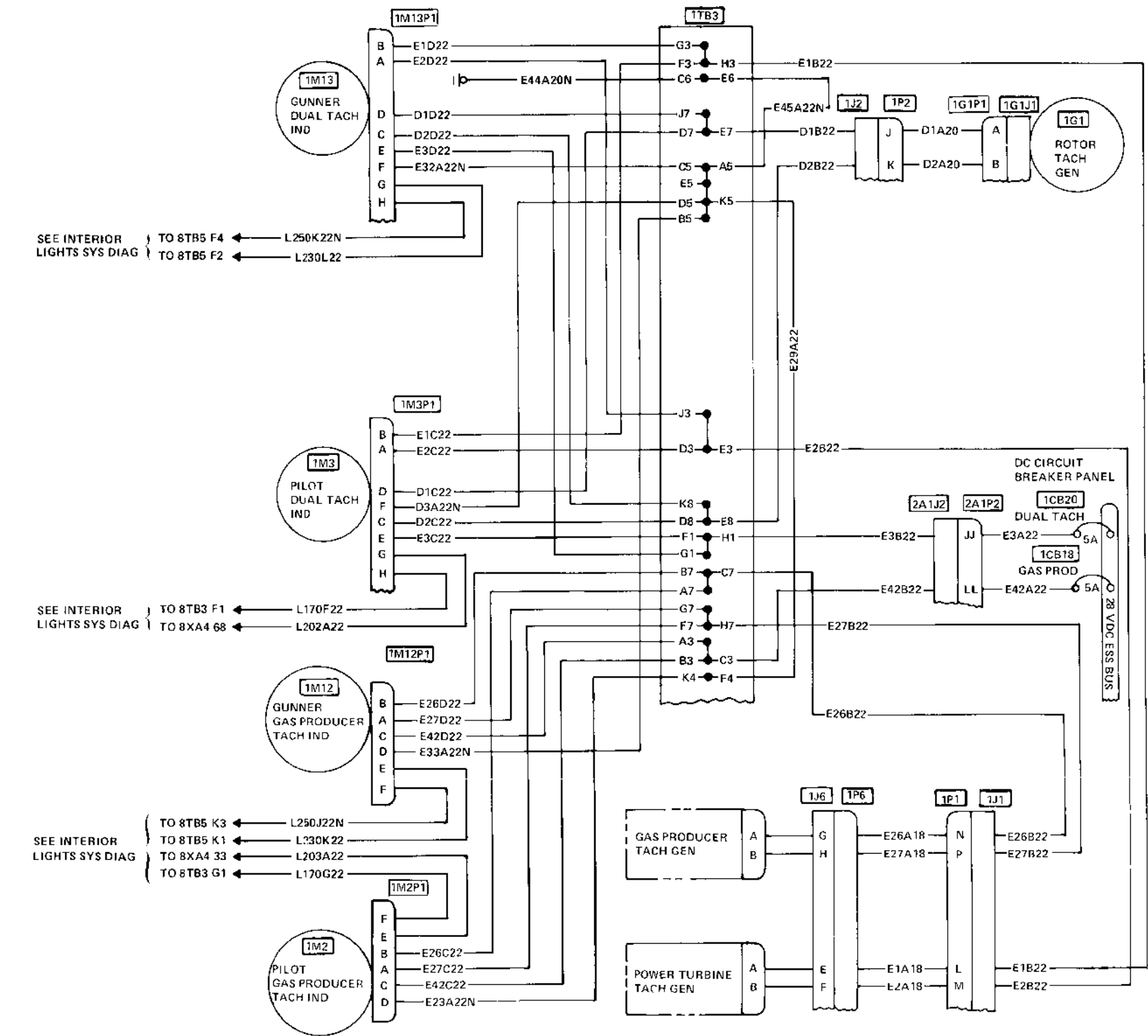

209475 335C

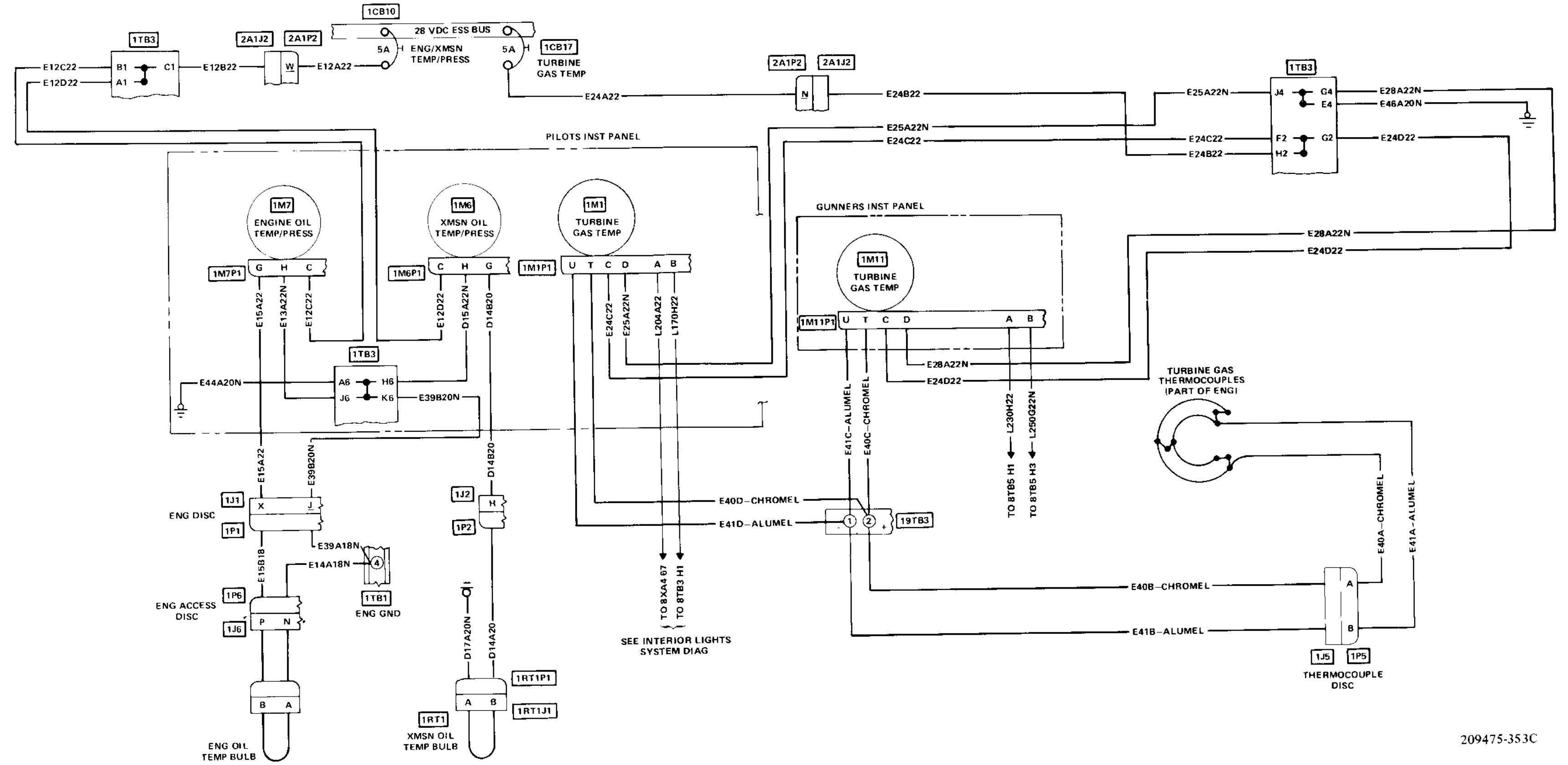

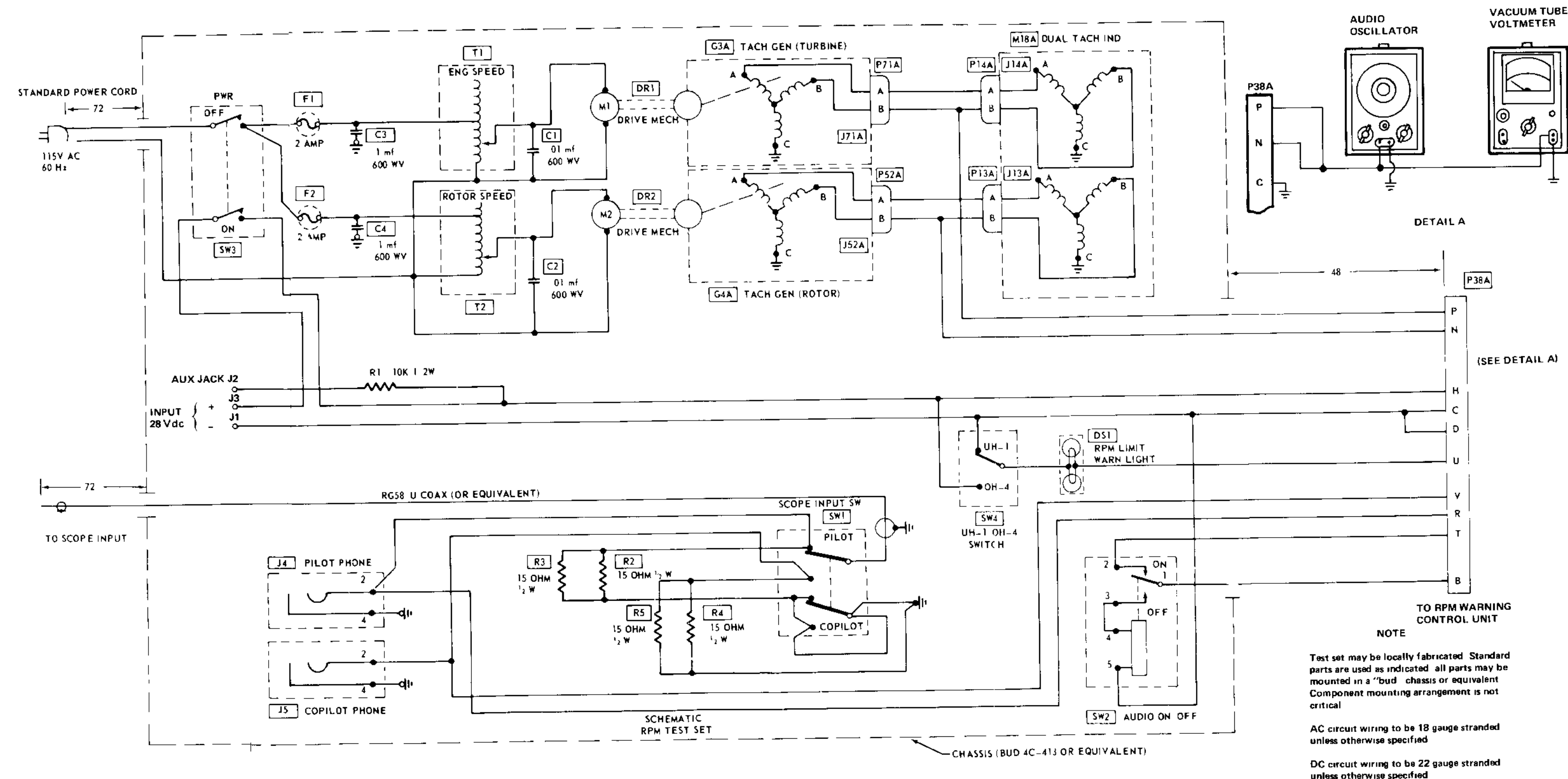

FREQ HZ	VRMS	ENG RPM	ROTOR RPM
66.5	19.5	6200	305
69.0	20.0	6400	315
73.5	22.0	6800	334
76.0	22.5	7000	-

ID CODE	NOMENCLATURE	PART NO
C1 C2	Line Filter 01 mf 600 WV	(Non Polarized)
C3 C4	Line Filter 1 mf 600 WV	(Non Polarized)
DR1 DR2	Rubber Flex Tube	Rubber Hose
DS1	Korrry Light (033 0861 001)	1/4 1 D (Bell) 205 074 026 1)
F1 F2	Fuse Holder	HKF
G3A	Tach Generator (MIL G26611)	Type GEU 7/A
G4A	Tach Generator (MIL G26611)	Type GEU 7/A
J1 J2 J3	Banana Jack	Standard
J4 J5	Phone Jack	092 A/U
M1 M2	Tach Gen Drive Motor - Dayton Mod 2M037 - Ball Bearing 1/4 Shaft 1/10 HP 8000 RPM 115Vac 60 Hz	
M18A	Dual Tach Indicator - GE 8DJ67FBC Sub 1	(Bell) 204 070 055 1)
P13A	Plug Dual Tach Indicator	MS3106R14S 7S
P14A	Plug Dual Tach Indicator	MS3106R14S 7S
P38A	Plug Eng RPM Warning Control	MS3126F14 19S
P52A	Plug Tach Generator	MS3108R12S 3S
P71A	Plug Tach Generator	MS3108R12S 3S
R1	Resistor 10K OHM 1/2W Carbon	(Tol 5%)
R2 R3	Resistor 15 OHM 1/2W Carbon	(Tol 5%)
R4 R5	Resistor 15 OHM 1/2W Carbon	(Tol 5%)
SW1	Switch Scope Input	MS24659 23G
SW2	Switch Audio On/Off (Micro)	5 E-T1 S
SW3	Switch Power On/Off	MS35059 22
T1 T2	Speed Control - Power Stat Superior Electric Co (0 140Vac 60 Hz)	Type 10B

NOTE  
Test set may be locally fabricated. Standard parts are used as indicated. All parts may be mounted in a "bud" chassis or equivalent. Component mounting arrangement is not critical.  
AC circuit wiring to be 18 gauge stranded unless otherwise specified.  
DC circuit wiring to be 22 gauge stranded unless otherwise specified.

CODE NO	EQUIPMENT	PART DESIGNATION	CKT LTR	NO TES	NO OF UNITS	OPER TIME MIN	ELECTRICAL REQUIREMENTS PER UNIT														
							115 VOLTS 3 PHASE			115 VOLTS 1 PHASE			26 VOLTS 1 PHASE			PWR FACT	VOLTAGE		FREQ		PWR SOR INF
							VA	WATTS	VAR	VA	WATTS	VAR	VA	WATTS	VAR		MIN	MAX	MIN	MAX	
<b>AC BUS SYS</b>																					
26 VAC																					
F085	FLIGHT INSTRUMENTS COURSE IND 212 070 180 3			F	1	15 00							9 12	1 46	9 00	0 160	24 5	27 5	300	420	SPEC
R053	RADIO NAV & COMM			R	1	15 00							4 01	2 52	3 12	0 629	24 5	27 5	380	420	MEA
R102	LF/ADF REC AN/ARN 89 VOR/LOC/GS AN/ARN 123				1	15 00							10 40	8 32	6 24	0 800	24 5	27 5	380	420	SPEC
X023	AC POWER PF COR CAP 5 MFD 100V			X	1	15 00							8 60	1 71	8 43	0 189	24 5	27 5	360	440	MEA
115 VAC																					
C032	FLIGHT CONTROLS SCAS SYS			C	1	15 00				69 00	59 34	35 21				0 860	108 0	118 0	360	440	MEA
E046	ENGINE INSTRUMENTS FUELQTSYS 209 060 602			E	1	15 00				2 92	2 91	0 26				0 996	107 5	119 5	360	440	MEA
E040A	FUELQTYIND				1																
E040B	FUELQTYXMR				2																
115 VAC ARMAMENT																					
F018	FLIGHT INSTRUMENTS COMPASSSYS AN/ASN 43			F	1	15 00										0 937	108 0	118 0	380	420	MEA
F018A	DIR GYRO (N-998) 1/ASN				1					16 39	15 36	6 73					108 0	118 0	380	420	MEA
F018B	XMTX T 0111 1/ASN /				1												108 0	118 0	380	420	MEA
F025	ATT GYRO LEAR SIGLER 9000C				1	15 00	17 94	15 93	8 25							0 888	108 0	118 0	380	420	MEA
F078	HSI IND 209 070 660				1	15 00				25 00	20 00	15 00				0 800	108 0	118 0	380	420	SPEC
F087	ATT INDBPH 209 075 661 1				1	15 00	10 57	9 99	3 45							0 945	108 0	118 0	380	420	SPEC
H068	HEATING RAD CPT BL 209 073 901 1			H	1	15 00				2 64	2 30	1 30				0 871	107 5	119 5	360	440	MEA
X025	AC POWER DC PWR SUP BENDIX 9840 1			X	1	15 00										0 980	108 0	118 0	360	440	CAL
<b>AC BUS TOW</b>																					
115 VAC (WITH TOW ENERGIZED)																					
A003	ARMAMENT HELMENT ST			A	1	15 00				13 35	13 35	0 0				1 000	107 5	119 5	380	420	MEA
A039	TURRET SYS M 197				1	15 00	82 88	82 73	4 97							0 996	108 5	117 5	360	420	MEA
X026	AC POWER DC PWR SUP BENDIX 9840 1			X	1	15 00										0 980	108 0	118 0	360	440	CAL
A001	ARMAMENT TOW REF ST XM 65			A	1	15 00	27 92	-24 53	13 14							0 882	108 5	117 5	380	420	MEA
A002	TOW MIS SY XM 65				1	15 00	110 64	104 23	37 11							0 942	108 5	117 5	380	420	MEA

**POWER SOURCE COMPONENT DATA**

ITEM	ALTERNATOR	STBY INVERTER	26V AC XFMR
No. Units	1	1	1
Rating	10 KVA	750 VA	150 VA
Voltage	115 VAC	115 VAC	26 VAC
Frequency	400 Hz	400 Hz	400 Hz
Power Factor	0 76 Lag	0 76 Lag	
Configuration	1 0 Lag	0 95 Lead	
	3 Phase	3 Phase	
	Wye	Wye	
Manufacturer	Bendix		
Model No	209 075	209 075	209 075
	997 1	572	363 1
Voltage Reg	+2 2%	2 2%	
	-8 7%		
Regulator P/N	409 376		
	203		
Frequency Reg	420 Hz to 360 Hz	2 5%	

EQUIPMENT	PART DESIGNATION	CKT LTR	NO OF TESTS UNITS	AMPS PER UNIT	OPER TIME MIN	MIN VOLT	MAX VOLT	PWR SDR INF	CONN LOAD	OPERATING CONDITIONS																	
										START AND WARM UP			TAKE OFF			CRUISE			CRUISE COMBAT			LAND			EMERGENCY		
										5 SEC	2 MIN	15 MIN	5 SEC	2 MIN	15 MIN	5 SEC	2 MIN	15 MIN	5 SEC	2 MIN	15 MIN	5 SEC	2 MIN	15 MIN	5 SEC	2 MIN	15 MIN
ESSENTIAL DC BUS																											
ARMAMENT																											
SQUIB WING BTJT																											
STORES MANGMT																											
ARMT RELAY																											
FLIGHT CONTROLS																											
HYD VALVE SOL																											
MAG BKE FR TRM																											
SCAS 13 CHANNEL																											
EMERHYDPUMP																											
EMERHYD SOL																											
EMERHYD RLY																											
EMER HYD RLY																											
INSTRUMENTS																											
XMSN OILT P IND																											
ENGINE INSTRUMENTS																											
TURBINE TEMP IND																											
GAS PRODUCER IND																											
TORQ PRESS IND																											
TORQUE PRESS IND																											
DUAL TACH IND																											
ENG OIL T P IND																											
FLIGHT INSTRUMENTS																											
GNR ATT IND																											
HEATING																											
DEFICING VALVE																											
ENGINE IGNITION																											
IGNITOR SYSTEM																											
IGNITOR PACK																											
ENG PRIM SOL																											
ENGINE CONTROLS																											
STARTER RELAY																											
LIGHTING																											
PLT INST LTS																											
CPT INST LTS																											
COCKPIT LIGHT																											
POWER																											
BATTERY CHRGNG																											
AC SOURCE RLY																											
AC CONTROL RLY																											
BAT COUNT RELAY																											
REV CU CTL RLY																											
ESSENTL RELAY																											
BATTERY RELAY																											
FUEL CONTROL																											
FUEL BOOST PUMP																											
FUEL SOL VALVE																											
FUEL CONT VALVE																											
GOV RPM ACT																											
IDLE STOP SOL																											
FUEL LOW RLY																											
OIL BY PASS SOL																											
OIL BY PASS RLY																											
RADIO NAV & COMM																											
INTERCOM SYS																											
VOR LOC OS MB																											
UHF COM SYS																											
UHF COM REC																											
UHF COM XMIT																											
RADAR																											
IFF/TRANSPONDER																											
TEST SET																											
COMPUTER KIT																											
RADAR ALTMETER																											
RADAR WARNING																											
WARNING & EMERGENCY																											
CAUT LT PANEL																											
RPM LIMIT WARN																											
FIRE DETECTION																											
RPM WARN LIMIT																											
MAST CAUT SYS																											
TOTAL ESSENTIAL DC BUS																											

POWER SOURCE COMPONENT DATA			
ITEM	STARTER GENERATOR	TRANSFORMER RECTIFIER UNIT	BATTERY
No Units	1	1	1
Rating	300 Amps	200 Amps	22 AH
Voltage	30 VDC	28 VDC	24 VDC
Frequency			
Power Factor		0.95 Lag	0.99 Lag
Configuration			
Manufacturer		Gen. Co.	
Model No.	204 060 200 1	205 075 999 1	BB 649 A
Voltage Reg.	3.5%	6 B 9	
Regulator P/N	205 075 228		
Frequency Reg.			

- NOTES
- THIS EQUIPMENT IS NORMALLY DEENERGIZED
  - ONE MINUTE OPERATION OUT OF EACH TEN MINUTES
  - ENERGIZED EXCEPT DURING DEICING
  - BATTERY LOAD DURING STARTING
  - BATTERY CHARGING VALUES CALCULATED
  - GENERATOR IS REMOVED FROM ESSENTIAL DC BUS DURING ARMAMENT CONFIGURATION TO SUPPLY ARMAMENT BUS POWER
  - SEVERAL WING STORES CONFIGURATIONS ARE POSSIBLE. THIS ANALYSIS IS BASED ON THE CONFIGURATIONS RESULTING IN THE HIGHEST DC LOAD THAT IS 2 XM 18 MISSILES ON INBOARD STATIONS AND 4 TOW MISSILES AT EACH OUTBOARD STATION
  - PROVISIONS ONLY

20475 452 1A



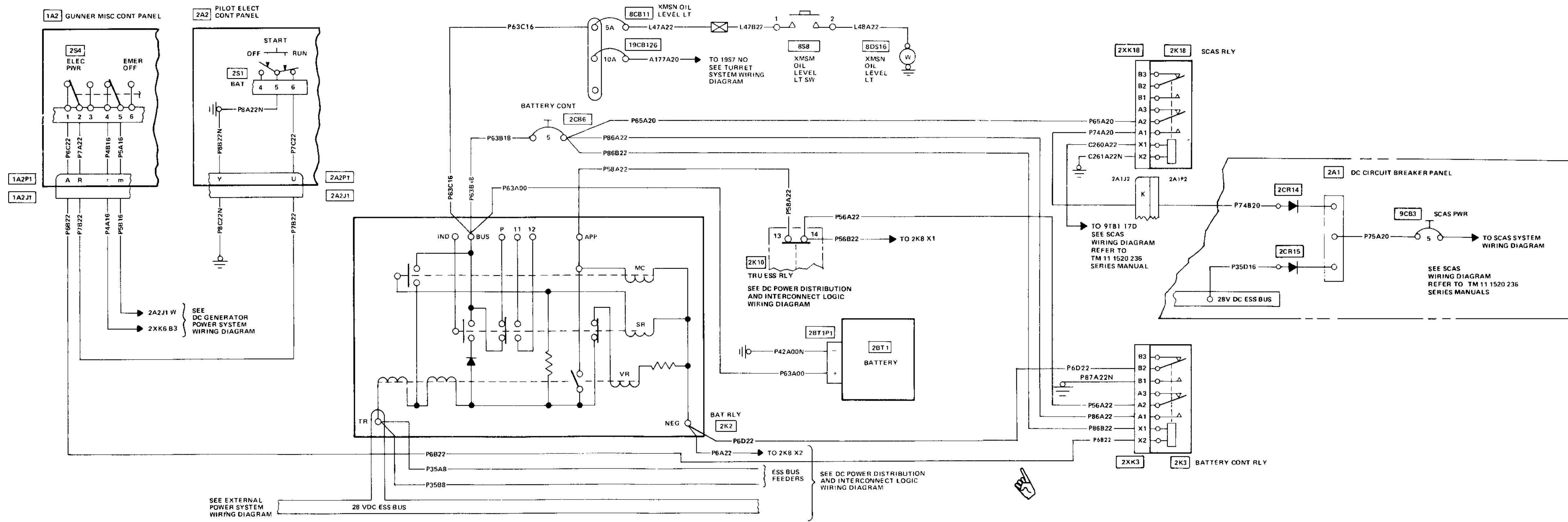



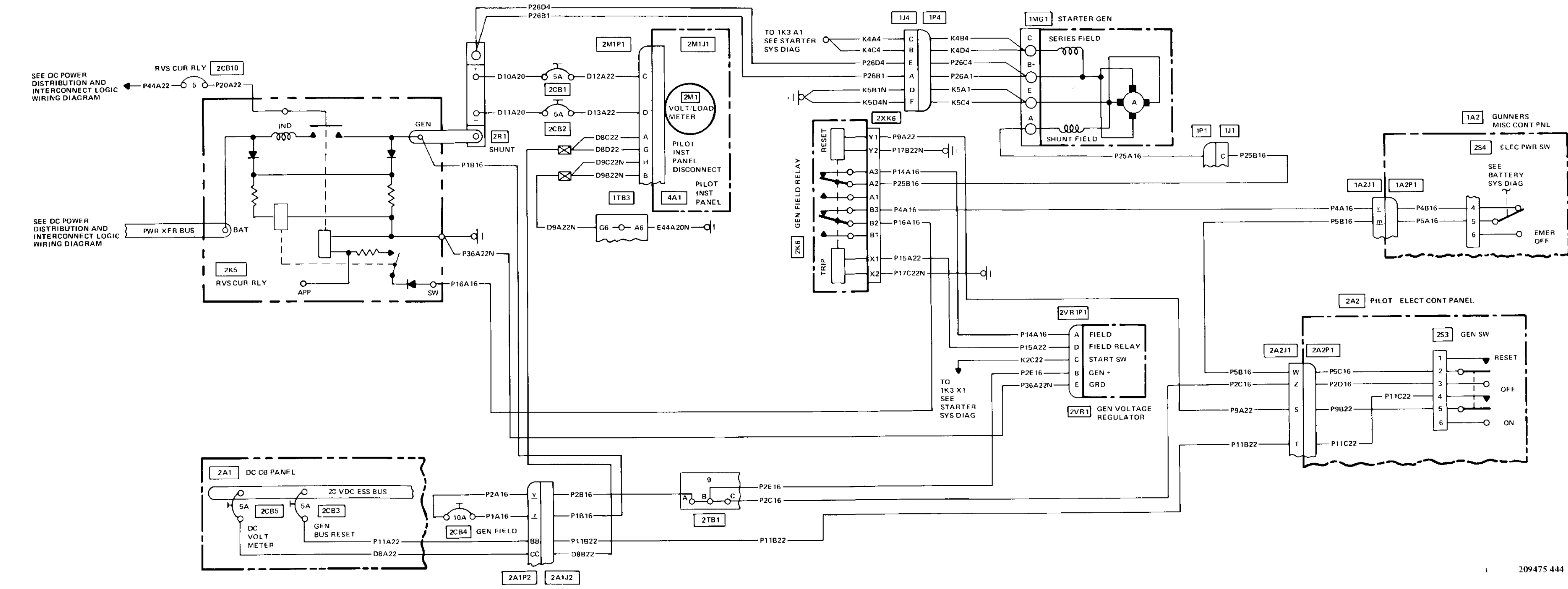

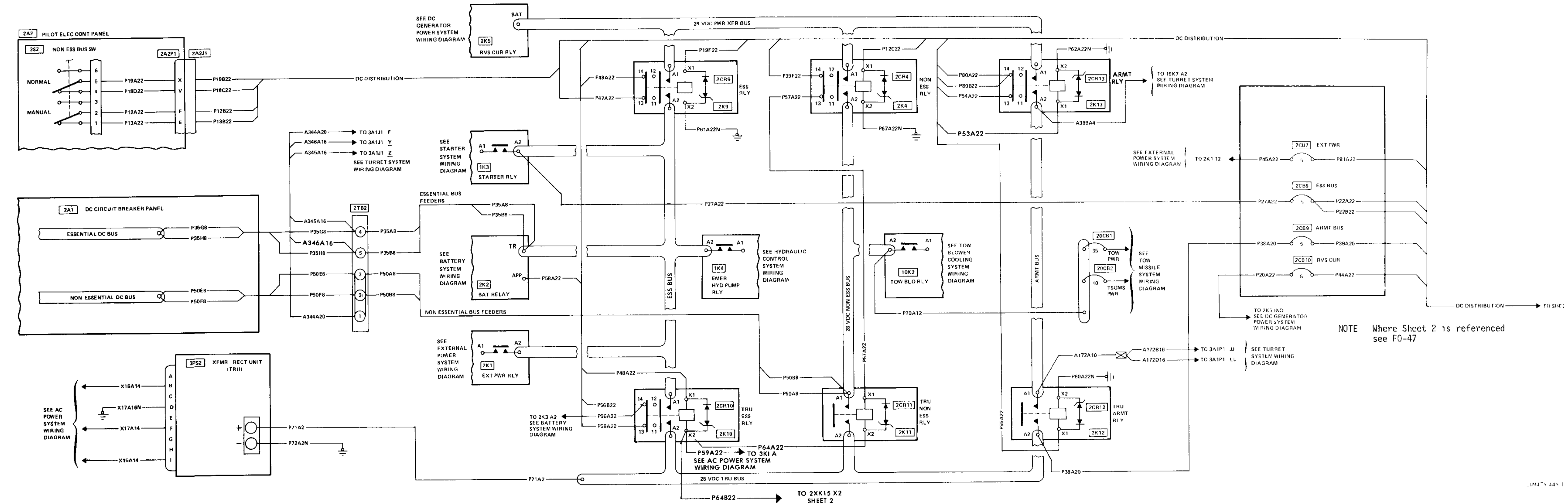

F0-46 DC Power Distribution and Interconnect Logic

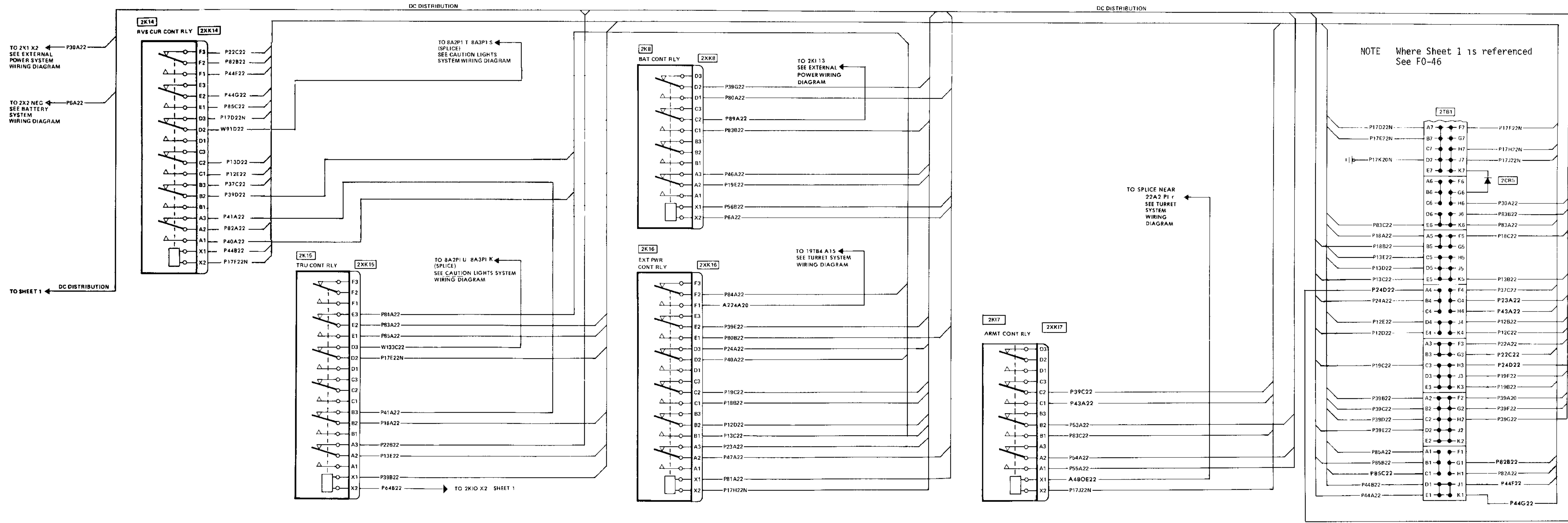

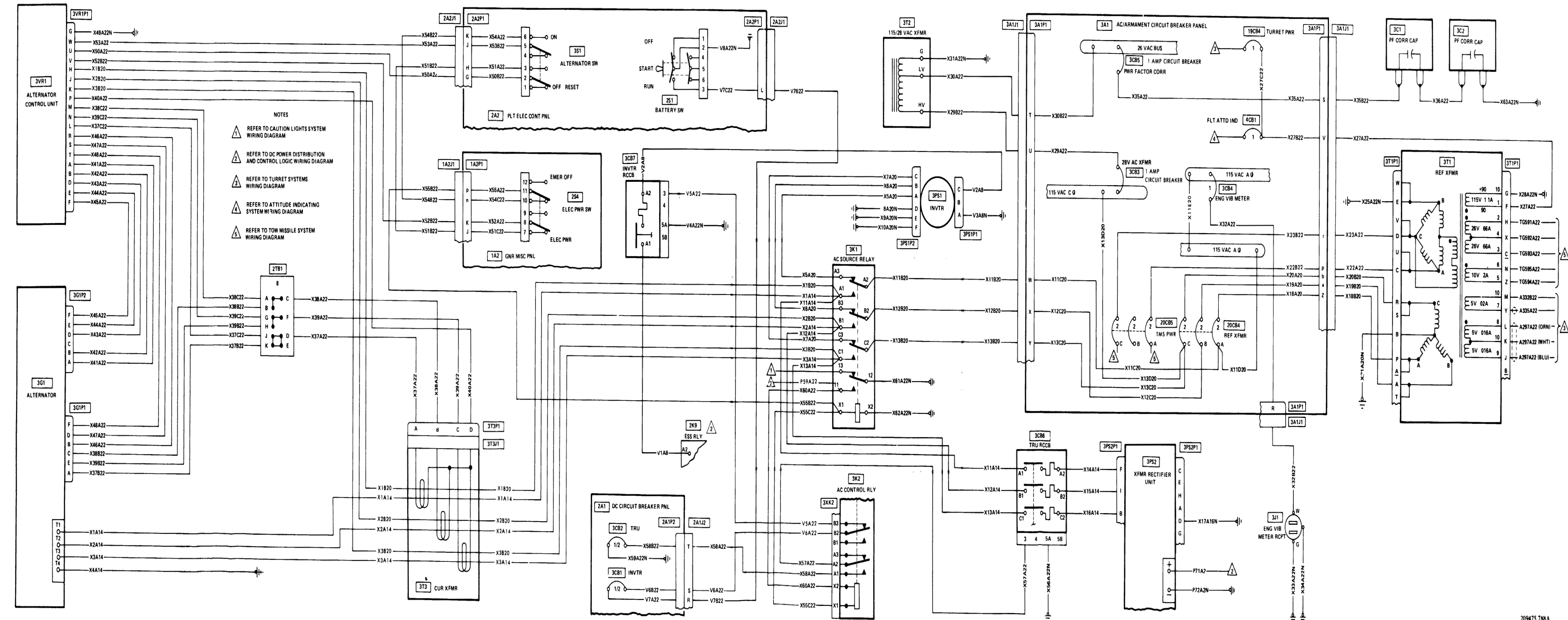

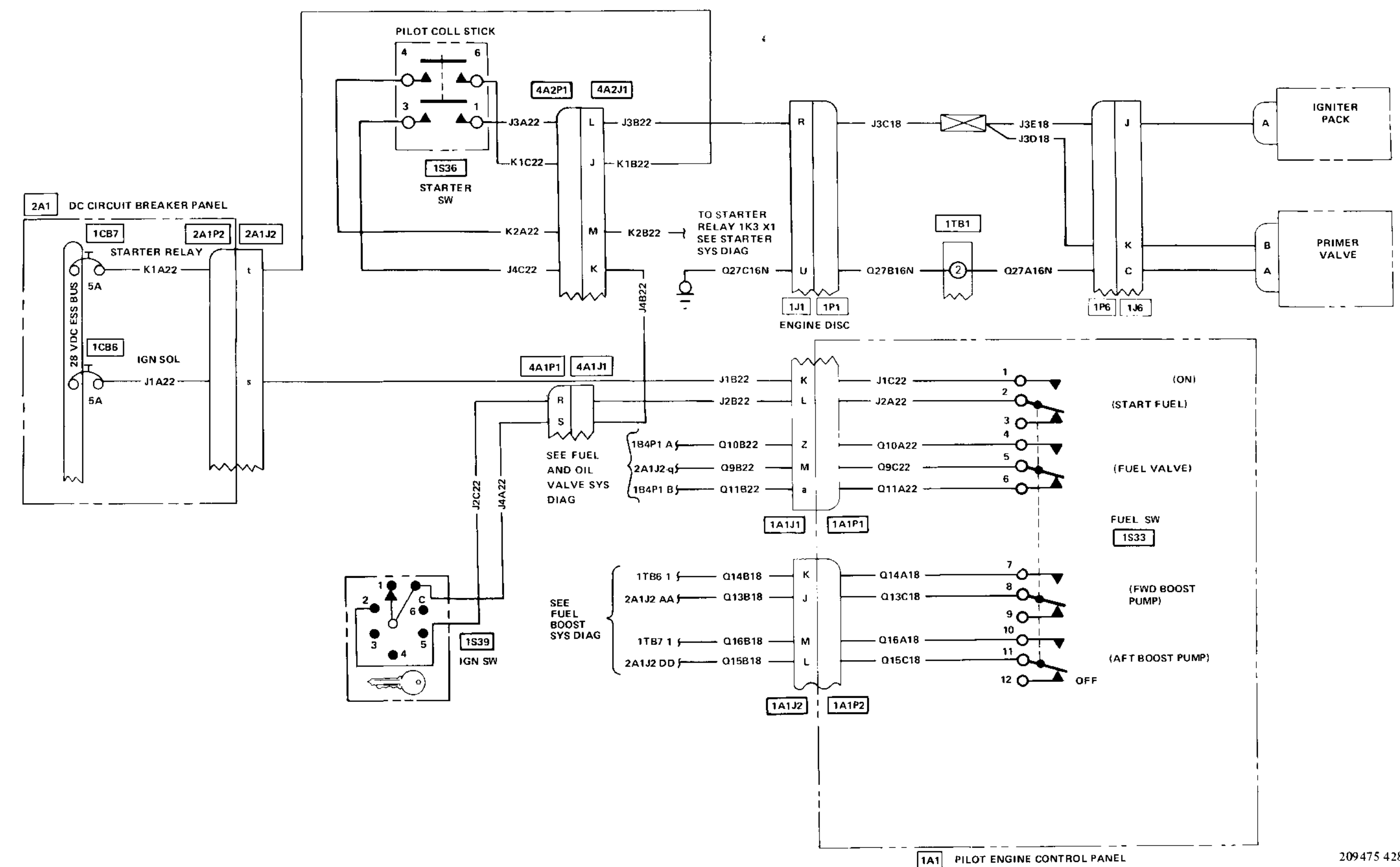

FO-49 Ignition System

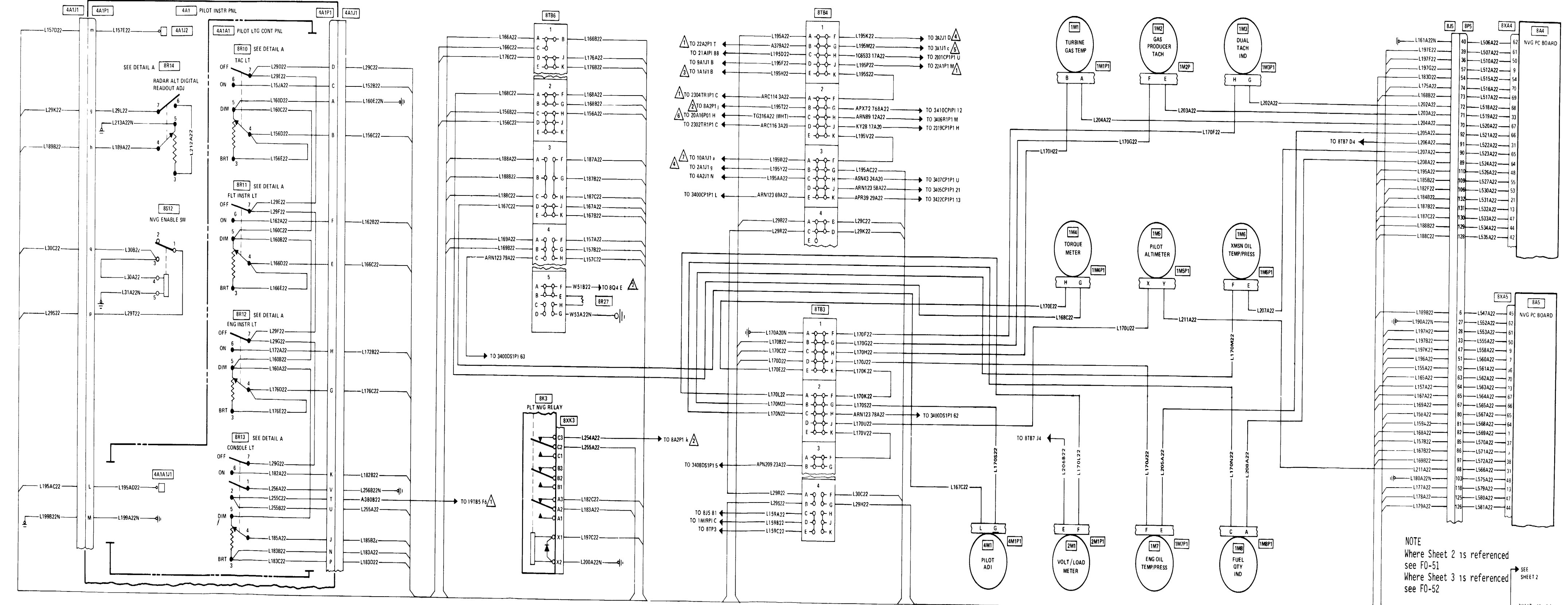

NOTE  
Where Sheet 2 is referenced  
see FO-51  
Where Sheet 3 is referenced  
see FO-52

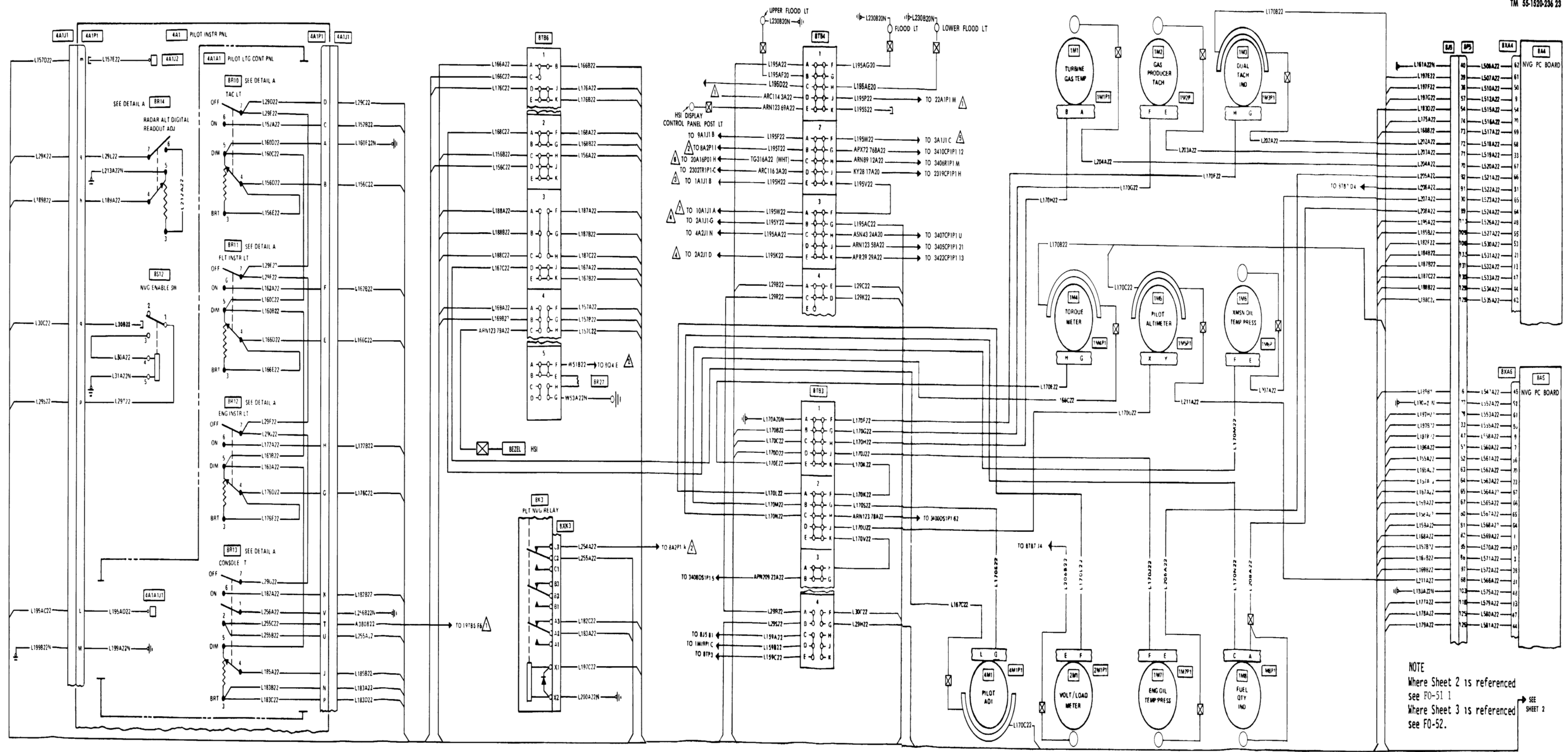

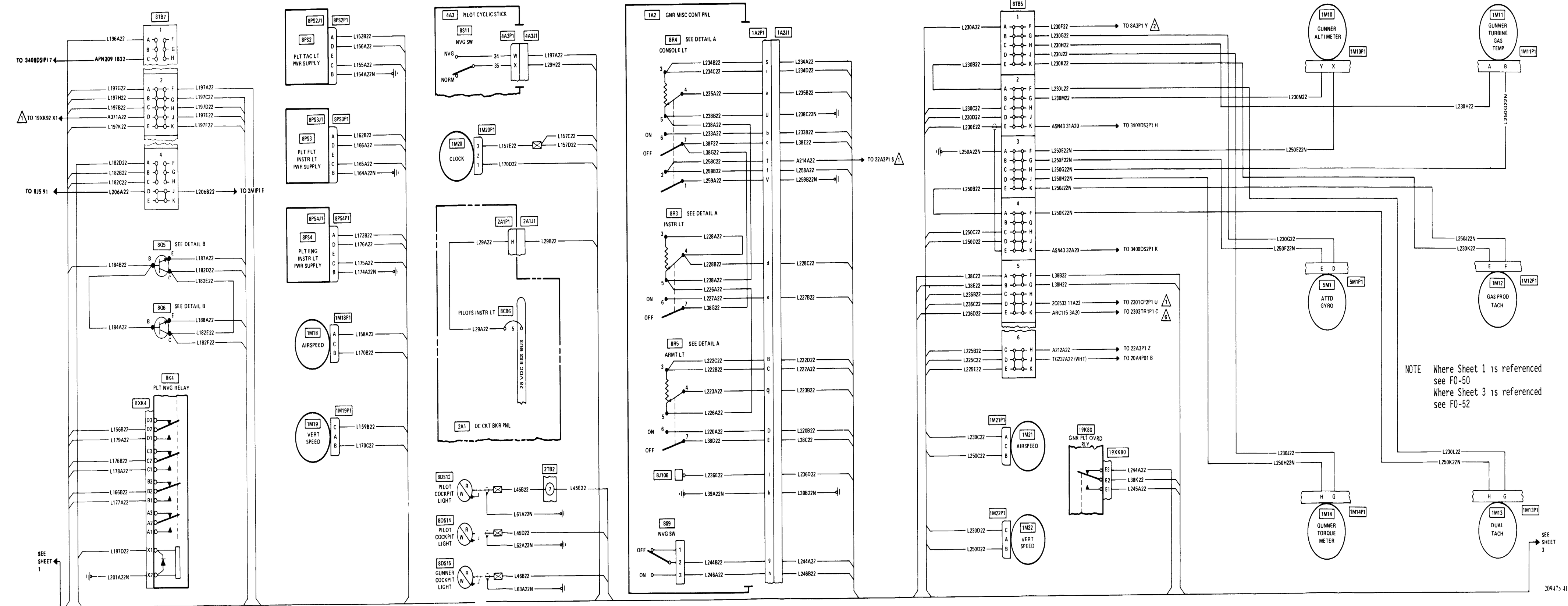



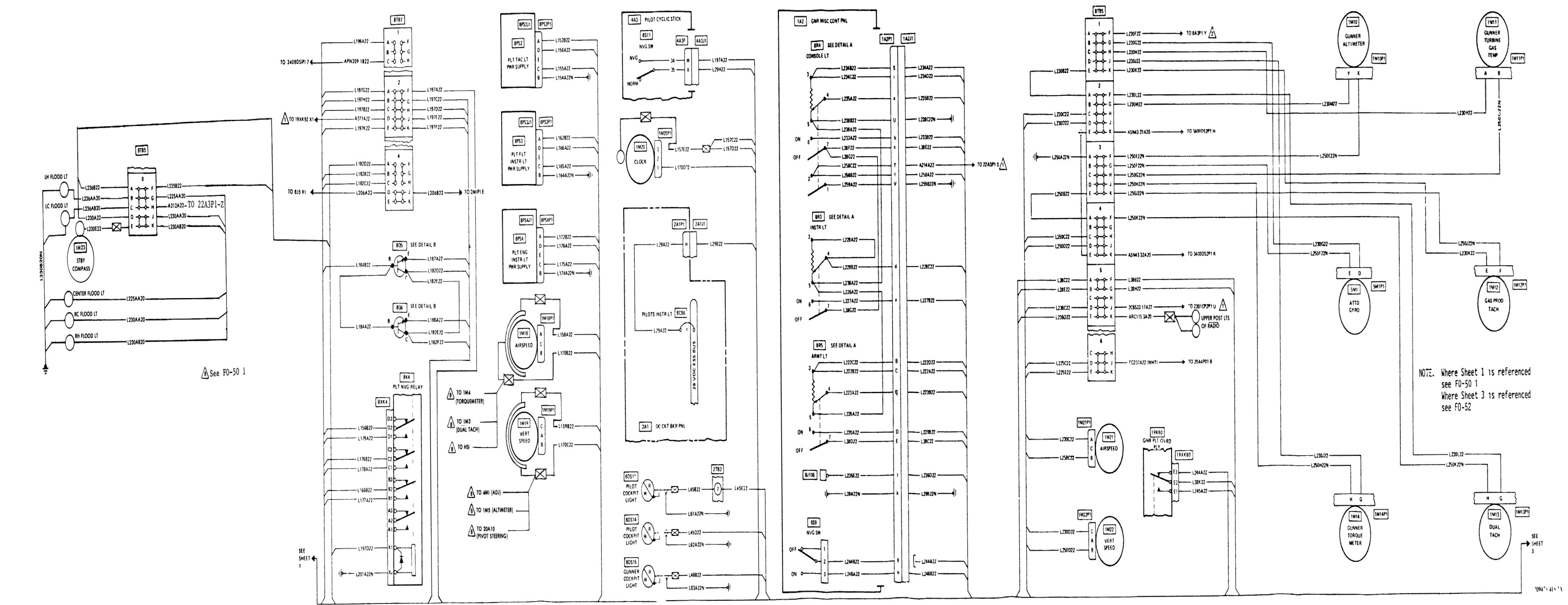

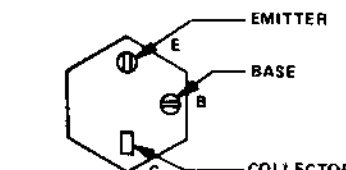
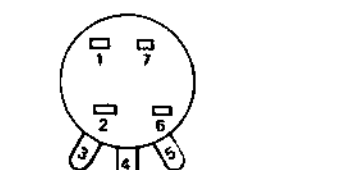
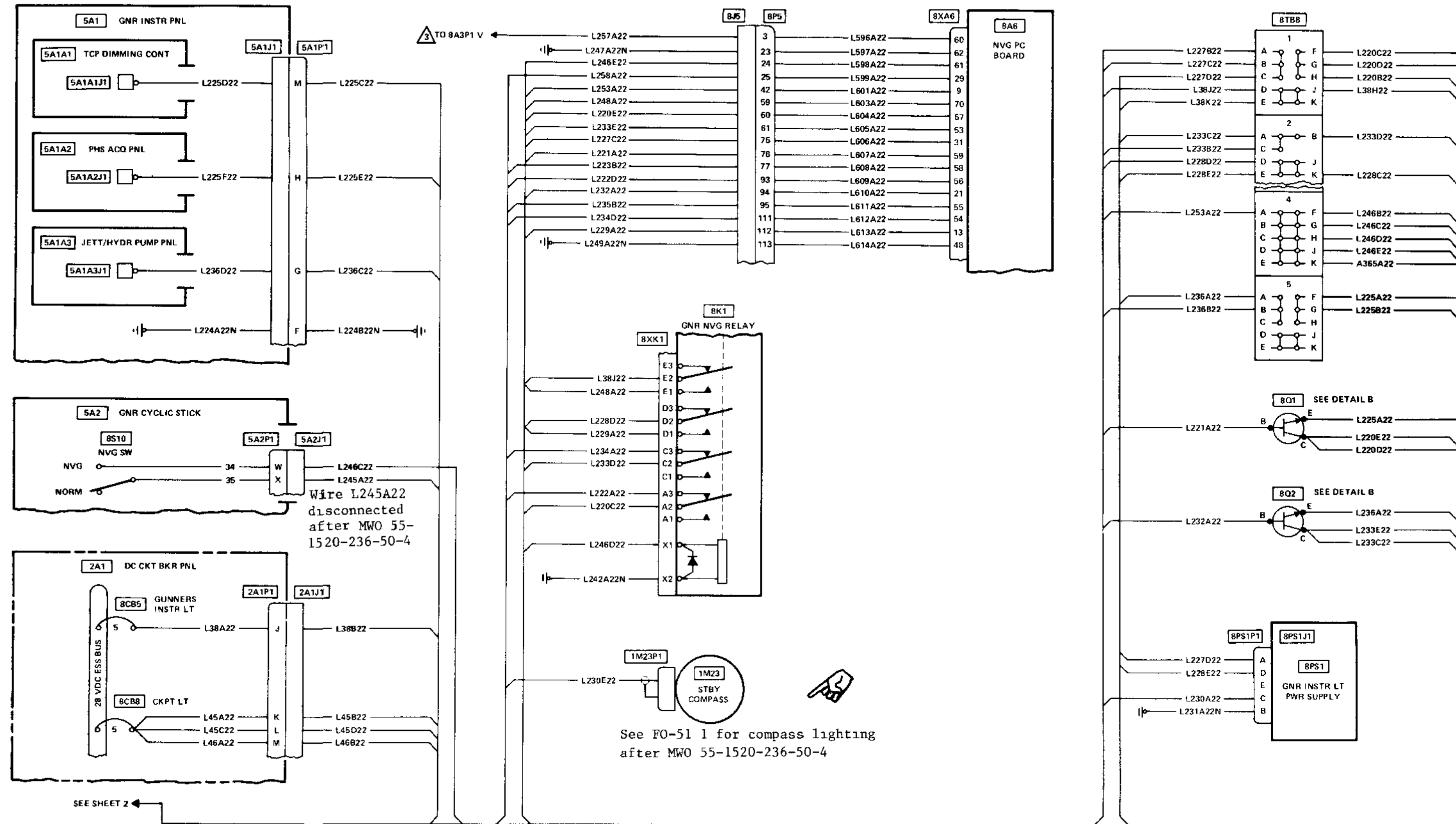

- NOTES
- ① SEE TURRET SYSTEM WIRING DIAGRAM
  - ② SEE CAUTION LIGHTS SYSTEM WIRING DIAGRAM
  - ③ SEE ENGINE SYSTEM WIRING DIAGRAM
  - ④ SEE DC POWER SYSTEM WIRING DIAGRAM
  - ⑤ SEE AC POWER SYSTEM WIRING DIAGRAM
  - ⑥ SEE TOW MISSILE SYSTEM WIRING DIAGRAM
  - ⑦ SEE ENVIRONMENTAL CONTROL SYSTEM WIRING DIAGRAM

NOTE Where Sheet 1 is referenced see FO-50  
Where Sheet 2 is referenced see FO-51

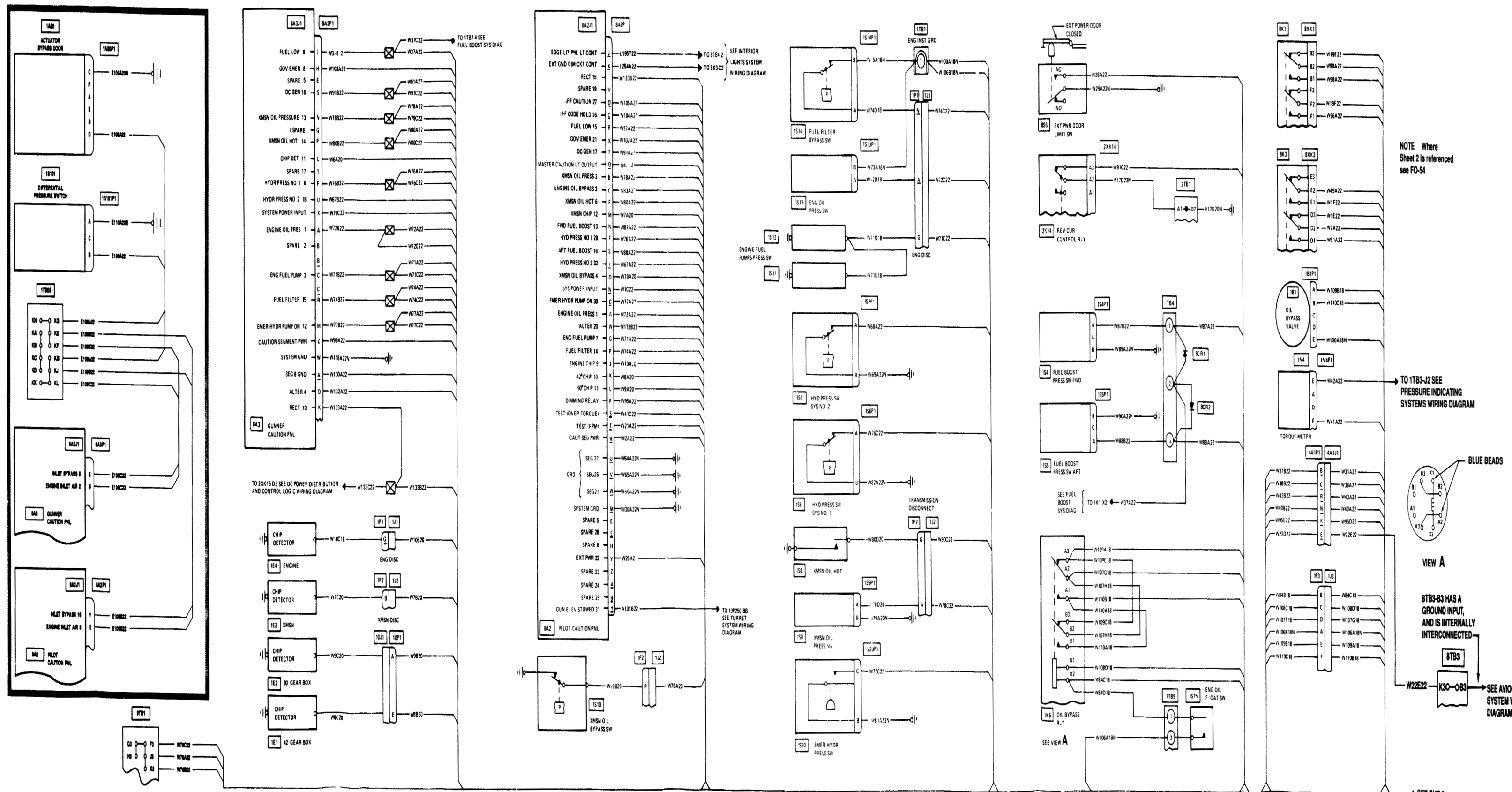

NOTE Where Sheet 2 is referenced see FO-54

TO 1TB3-12 SEE PRESSURE INDICATING SYSTEMS WIRING DIAGRAM

BLUE BEADS

VIEW A

8TB3-83 HAS A GROUND INPUT, AND IS INTERNALLY INTERCONNECTED

SEE AVONICS SYSTEM WIRING DIAGRAM

SEE SHIT 2

NOTE Where Sheet 1 is referenced see FO-53

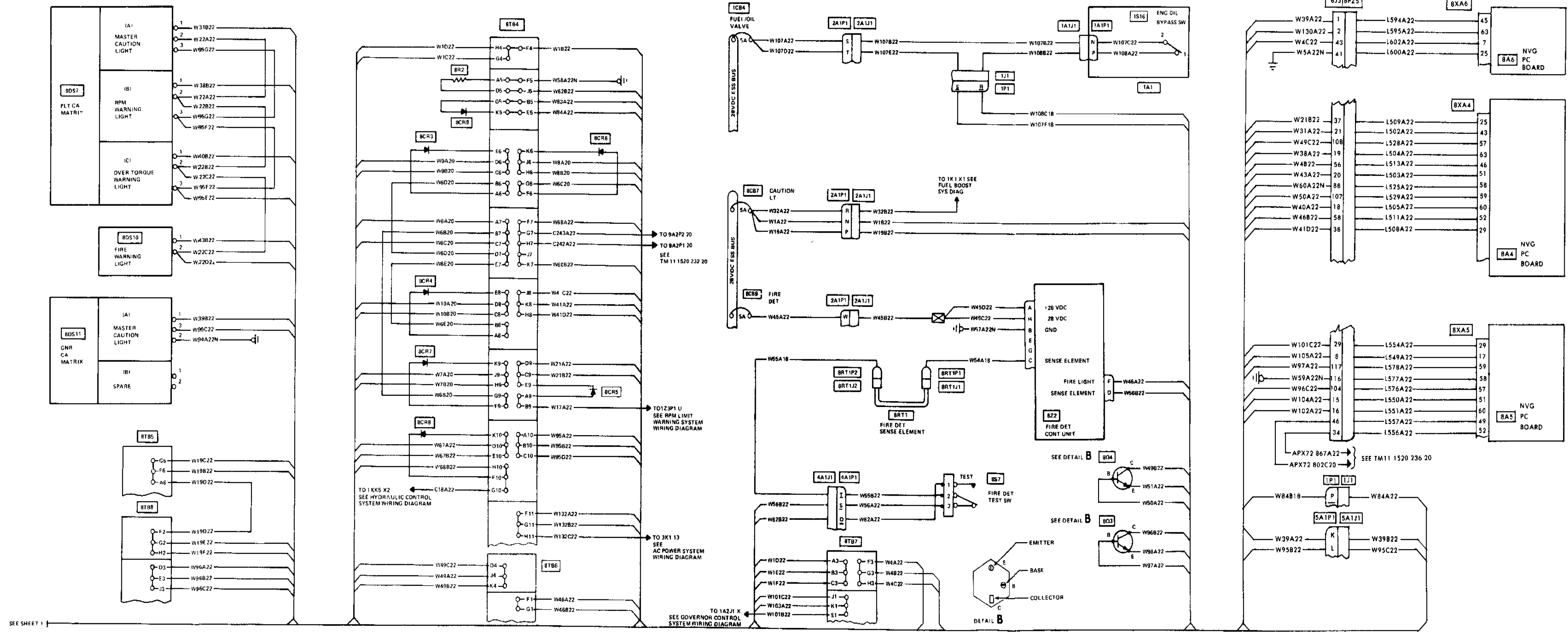

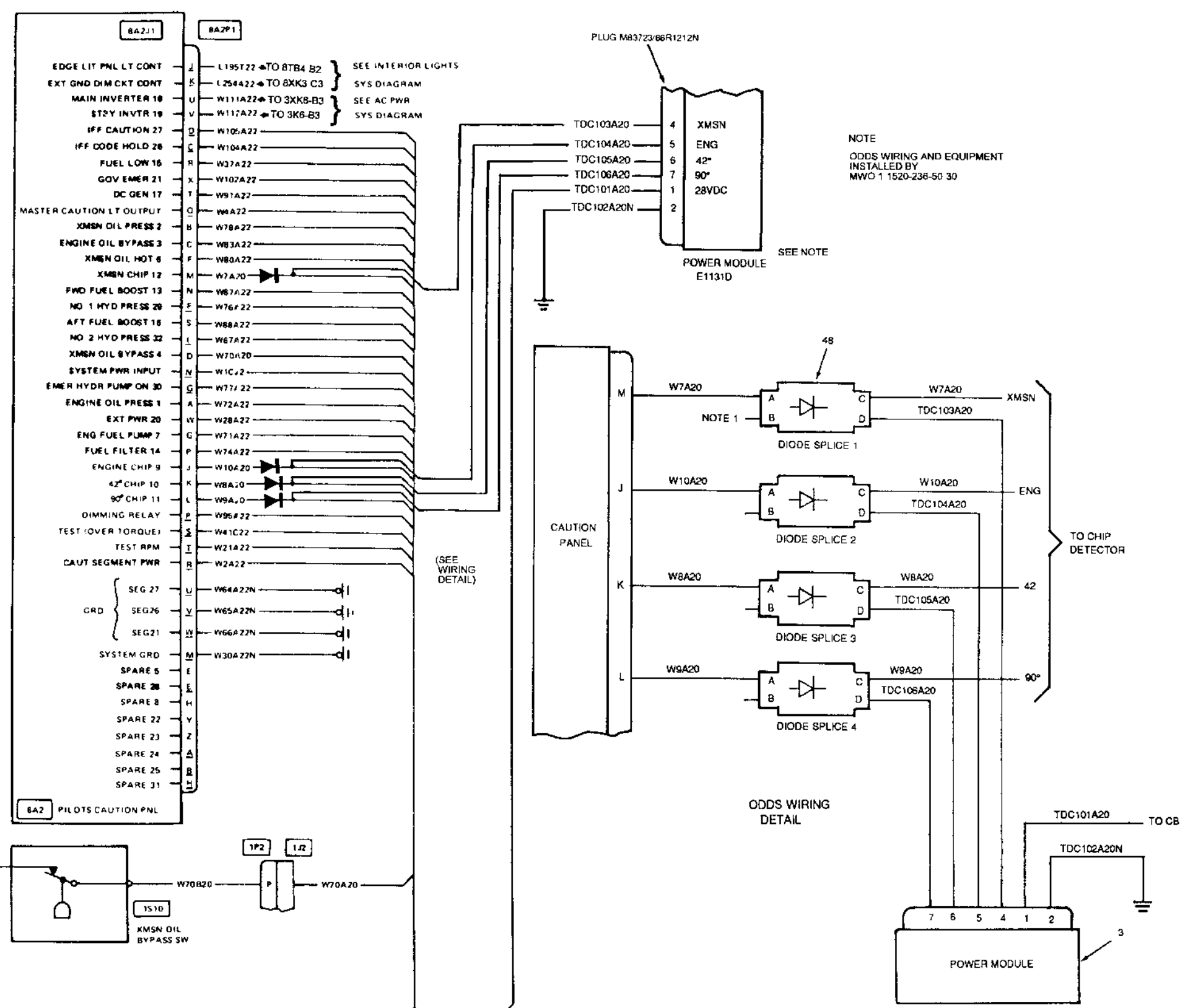
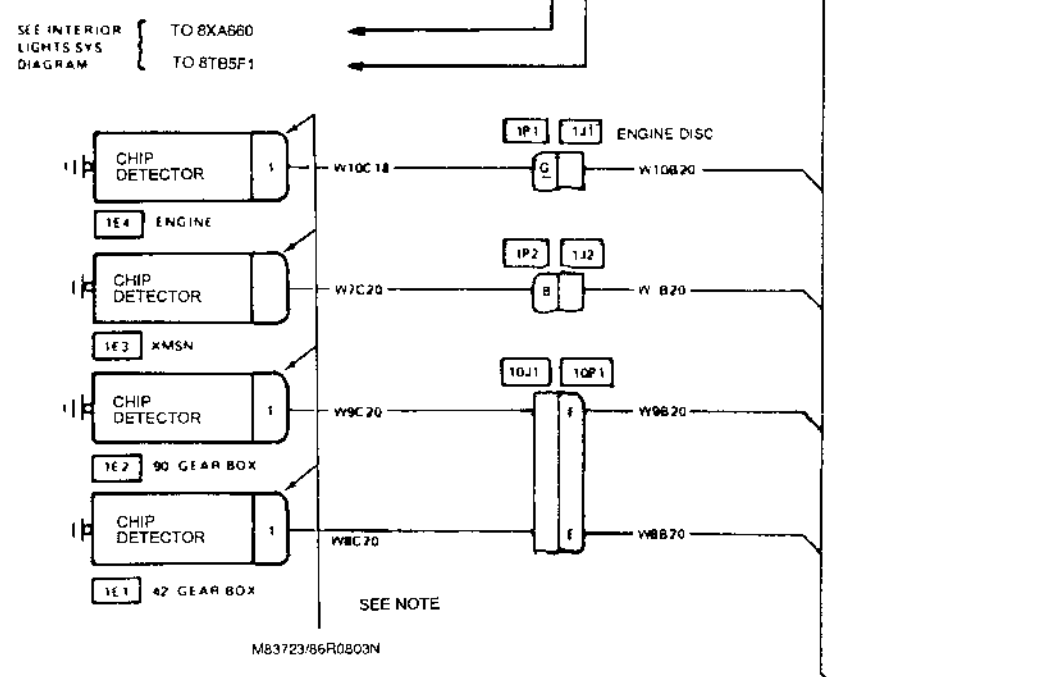
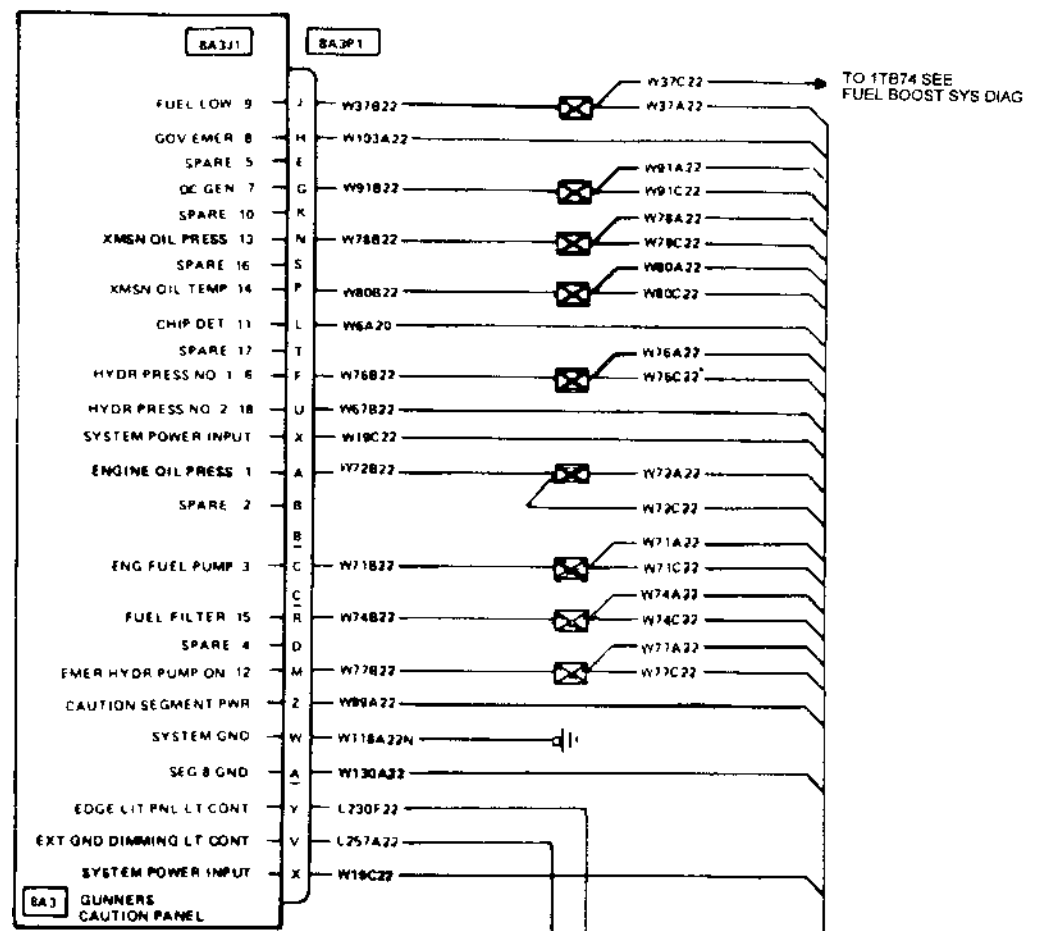

FO 54 1 Caution Lights System (After Incorporation of MWO 1-1520-236-50-30)

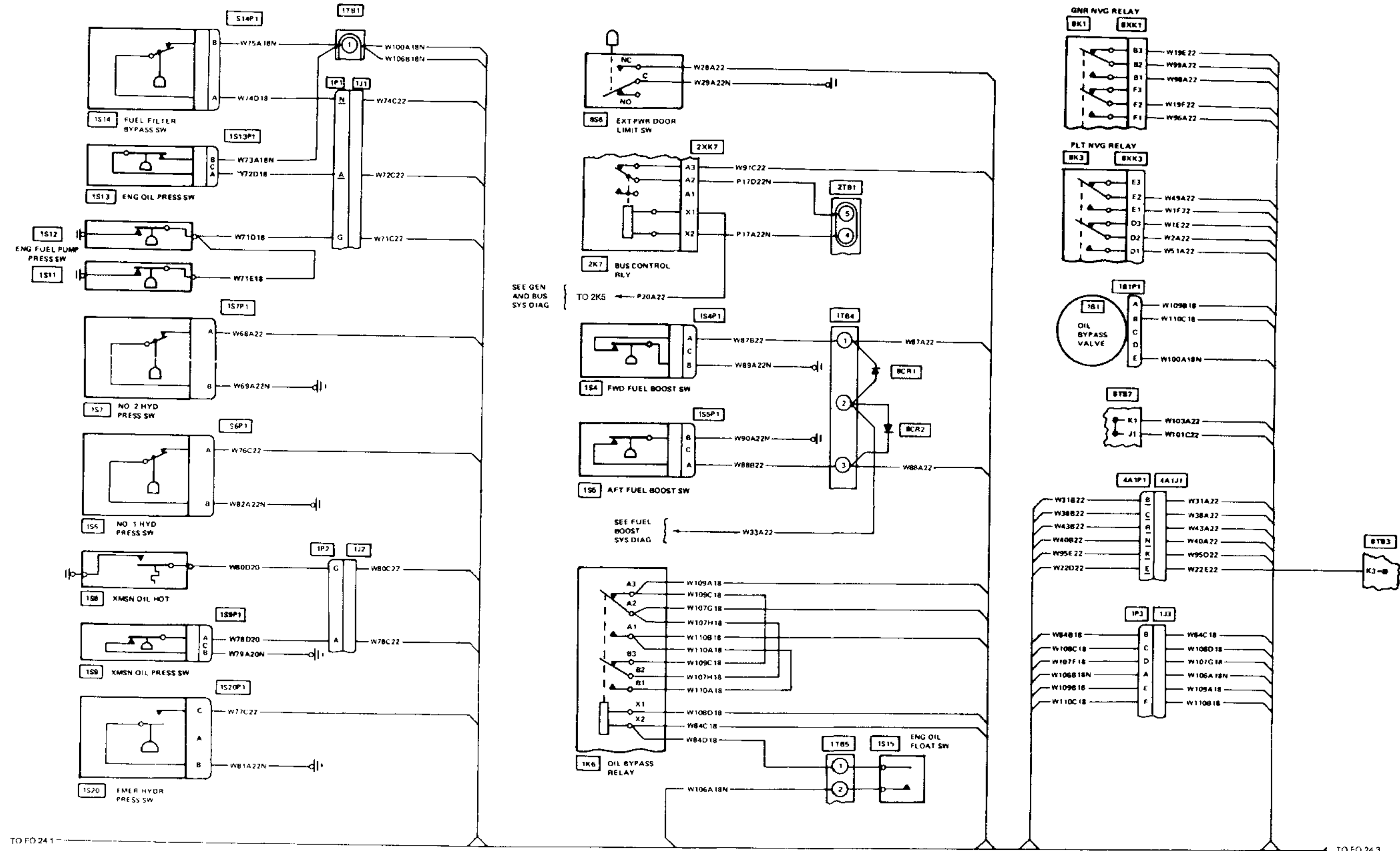

FO 54.2 Caution Lights System (After Incorporation of MWO 1-1520-236-50-30)

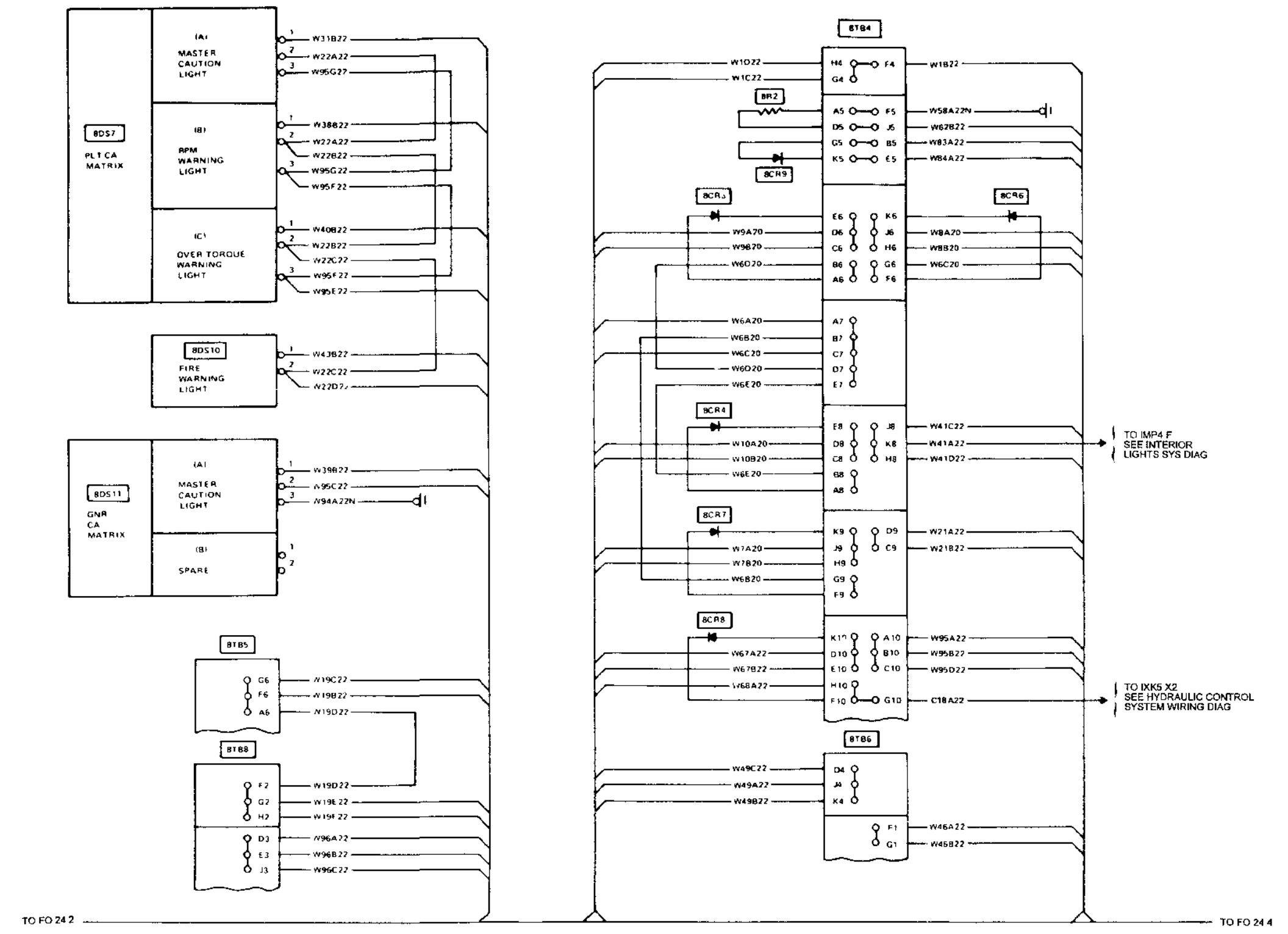

TO FO 24 2

TO FO 24 4

FO 54 3 Caution Lights System (After Incorporation of MWO 1-1520-236-50-30)

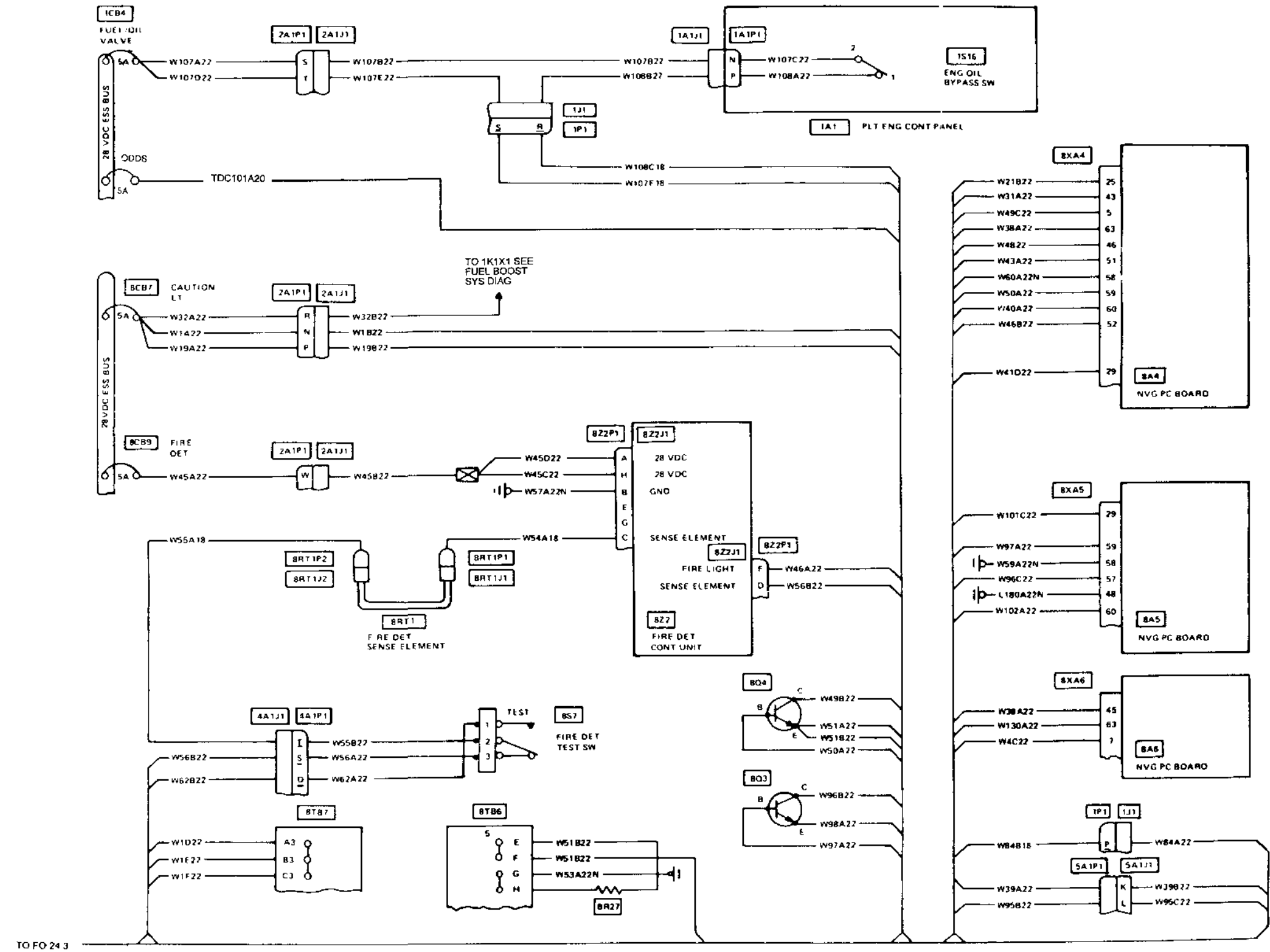

TO FO 24.3

FO 54.4 Caution Lights System (After Incorporation of MWO 1-1520-236-50-30)



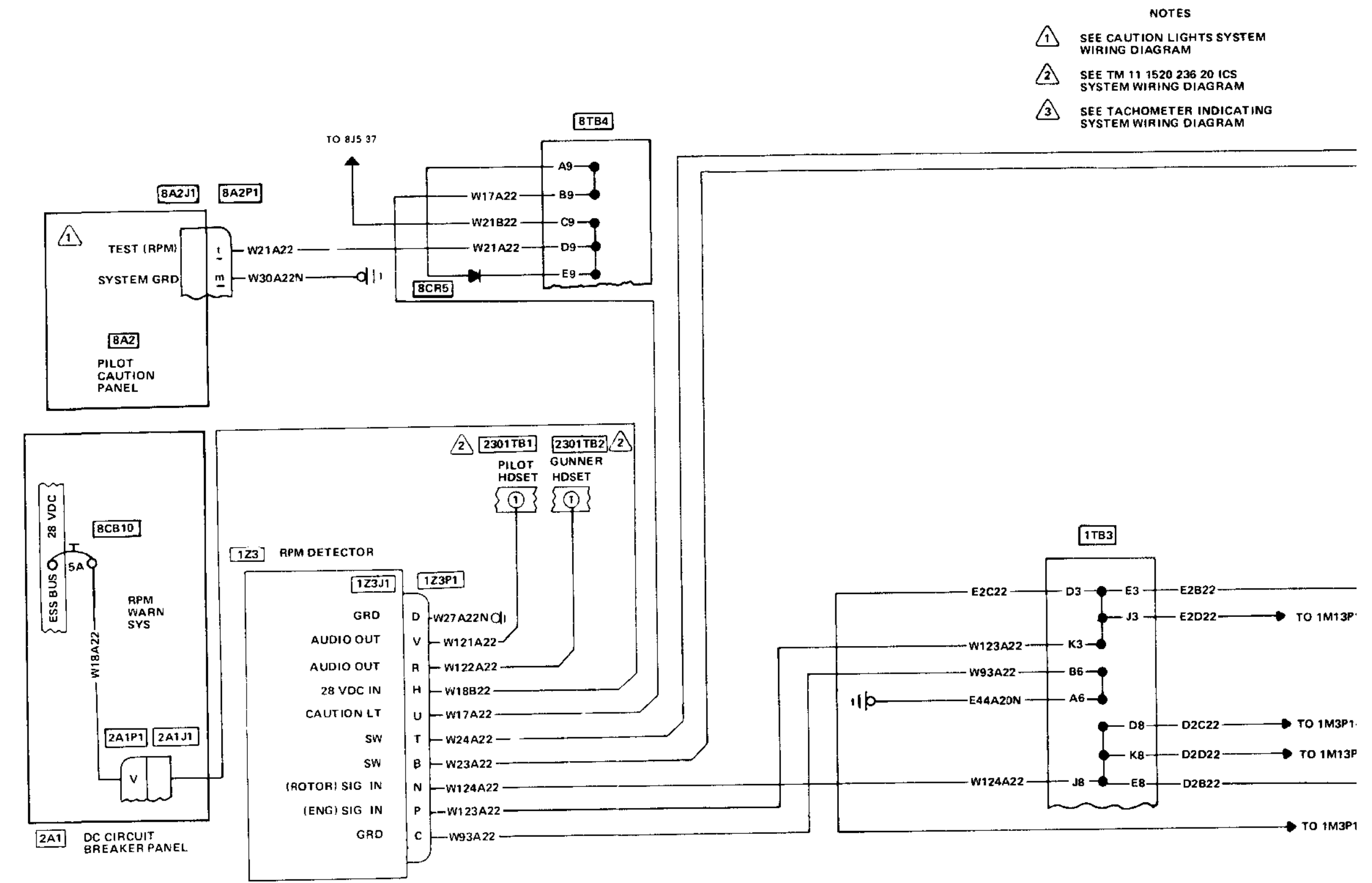

- NOTES
- 1 SEE CAUTION LIGHTS SYSTEM WIRING DIAGRAM
  - 2 SEE TM 11 1520 236 20 ICS SYSTEM WIRING DIAGRAM
  - 3 SEE TACHOMETER INDICATING SYSTEM WIRING DIAGRAM

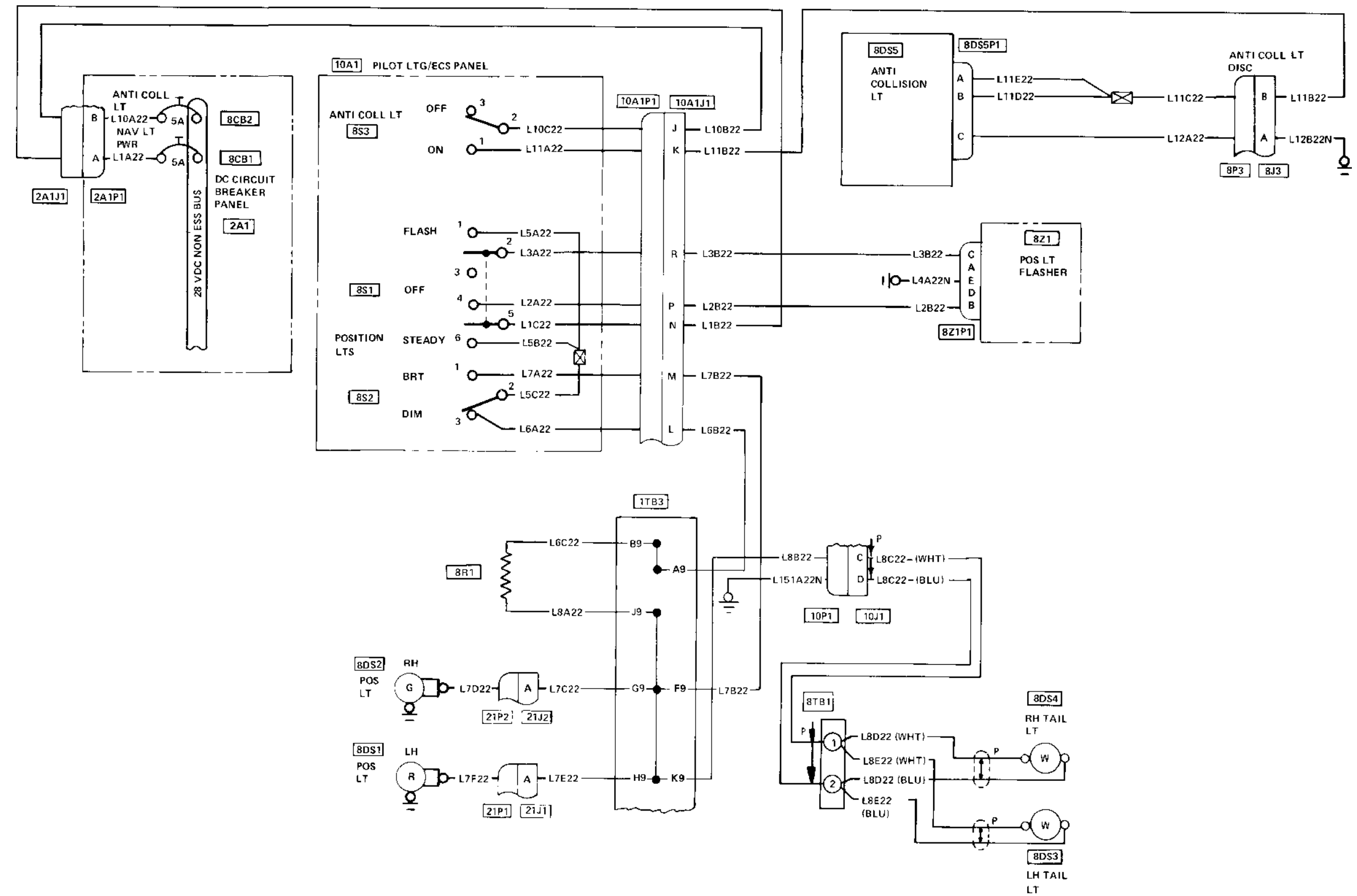

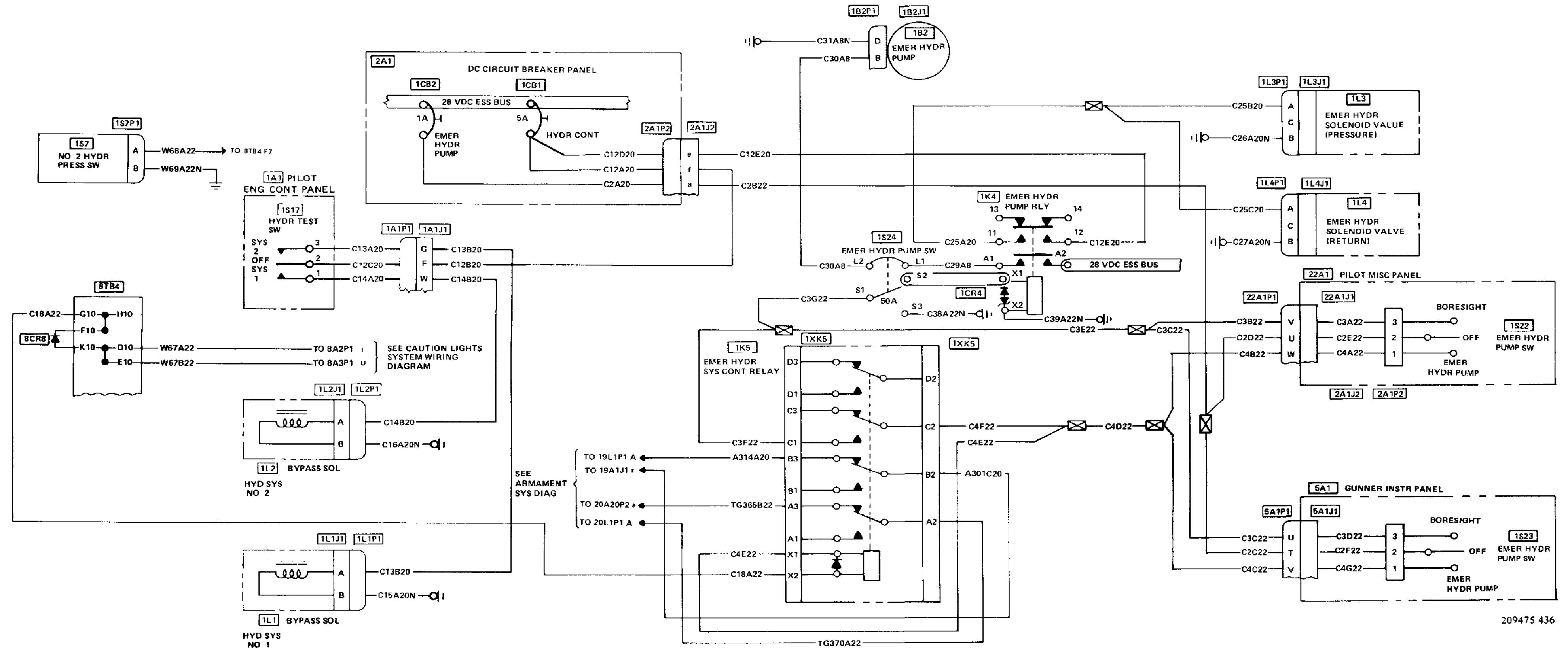

209475 436

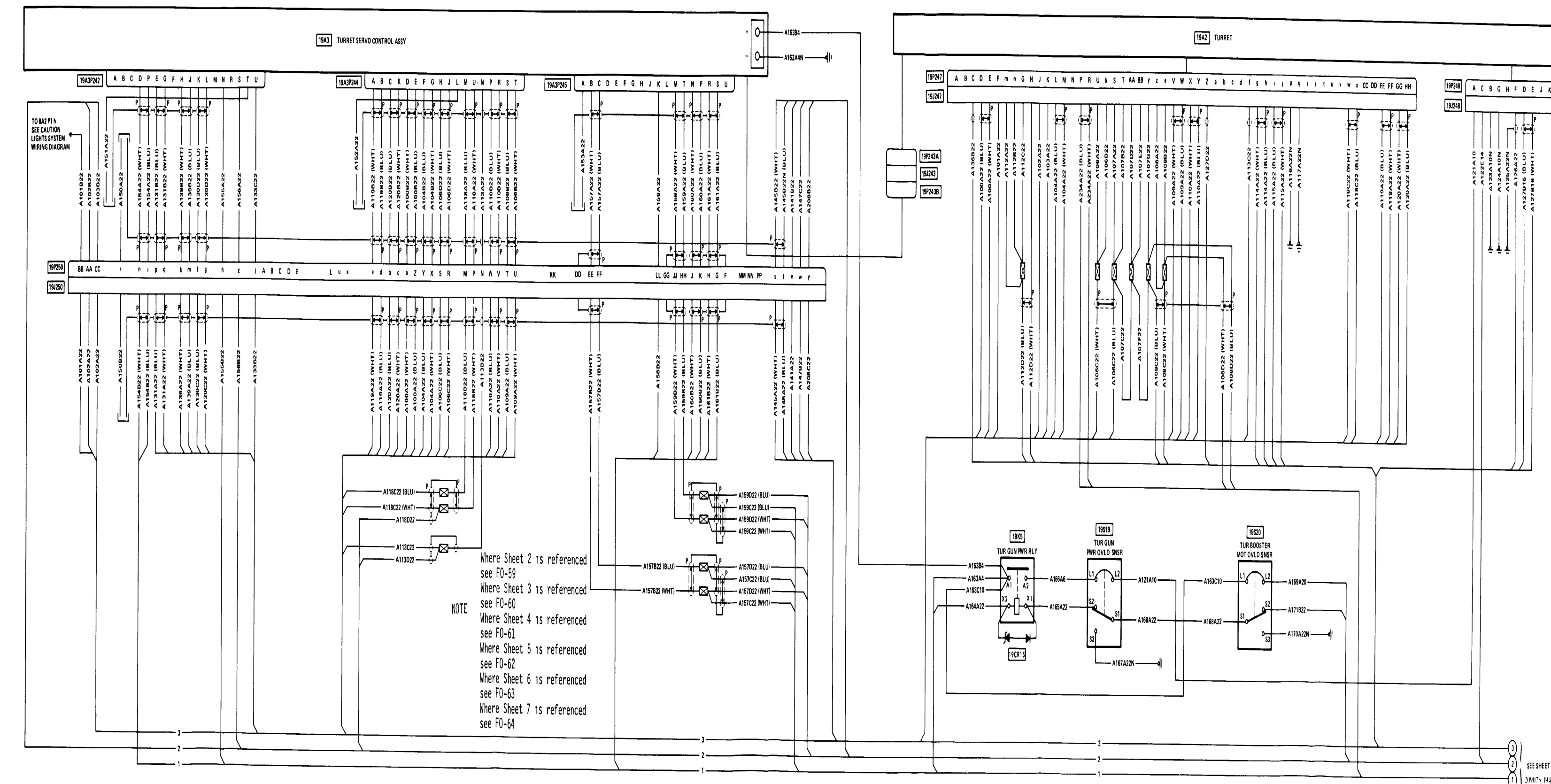

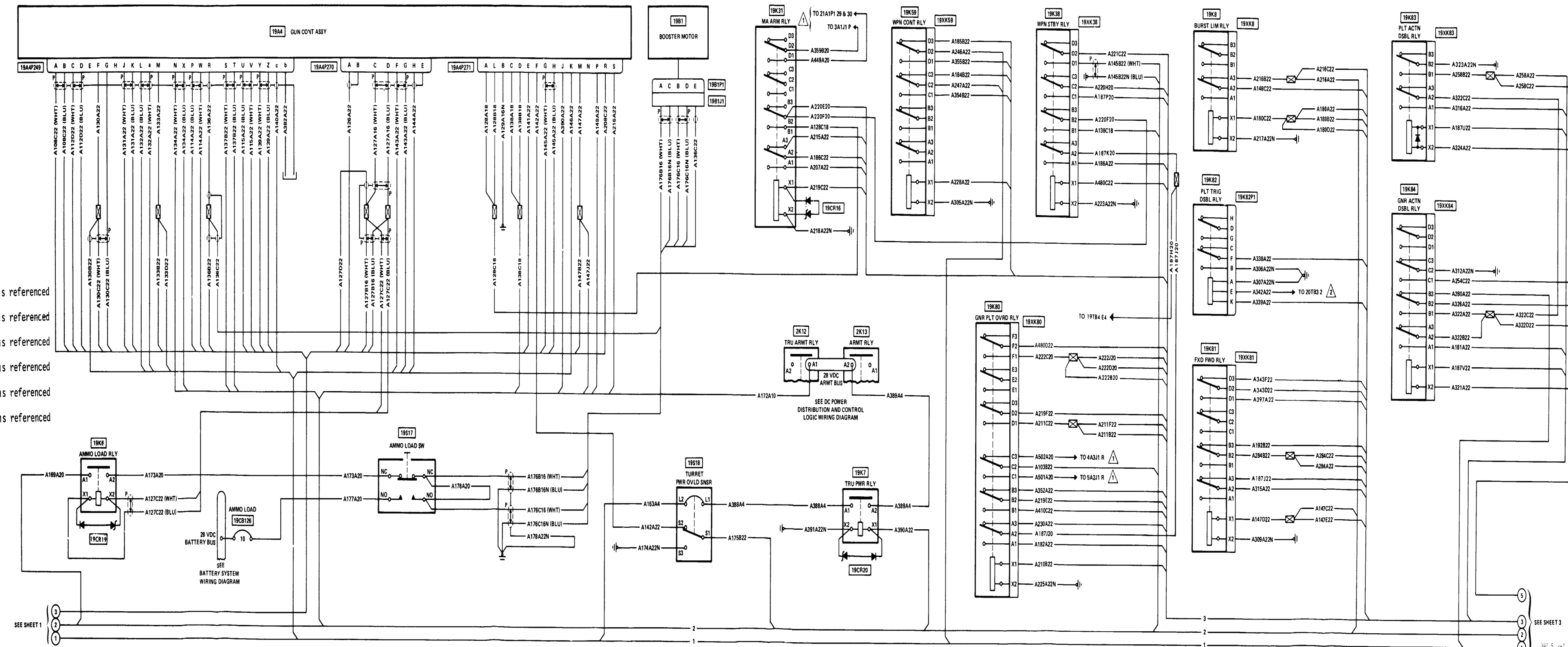

NOTE Where Sheet 1 is referenced see FO-58  
 Where Sheet 3 is referenced see FO-60  
 Where Sheet 4 is referenced see FO-61  
 Where Sheet 5 is referenced see FO-62  
 Where Sheet 6 is referenced see FO-63  
 Where Sheet 7 is referenced see FO-64



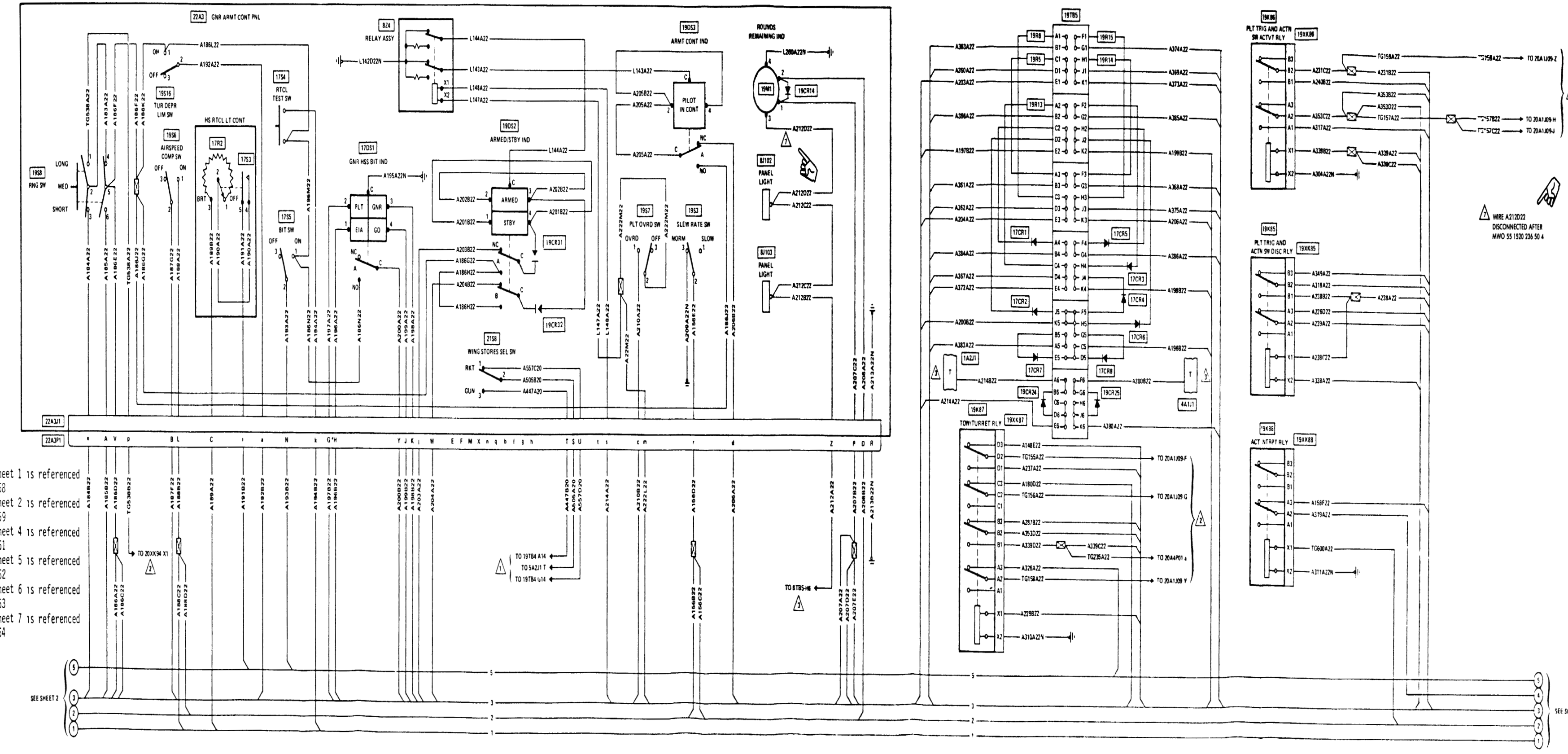

NOTE Where Sheet 1 is referenced see FO-58  
 Where Sheet 2 is referenced see FO-59  
 Where Sheet 4 is referenced see FO-61  
 Where Sheet 5 is referenced see FO-62  
 Where Sheet 6 is referenced see FO-63  
 Where Sheet 7 is referenced see FO-64

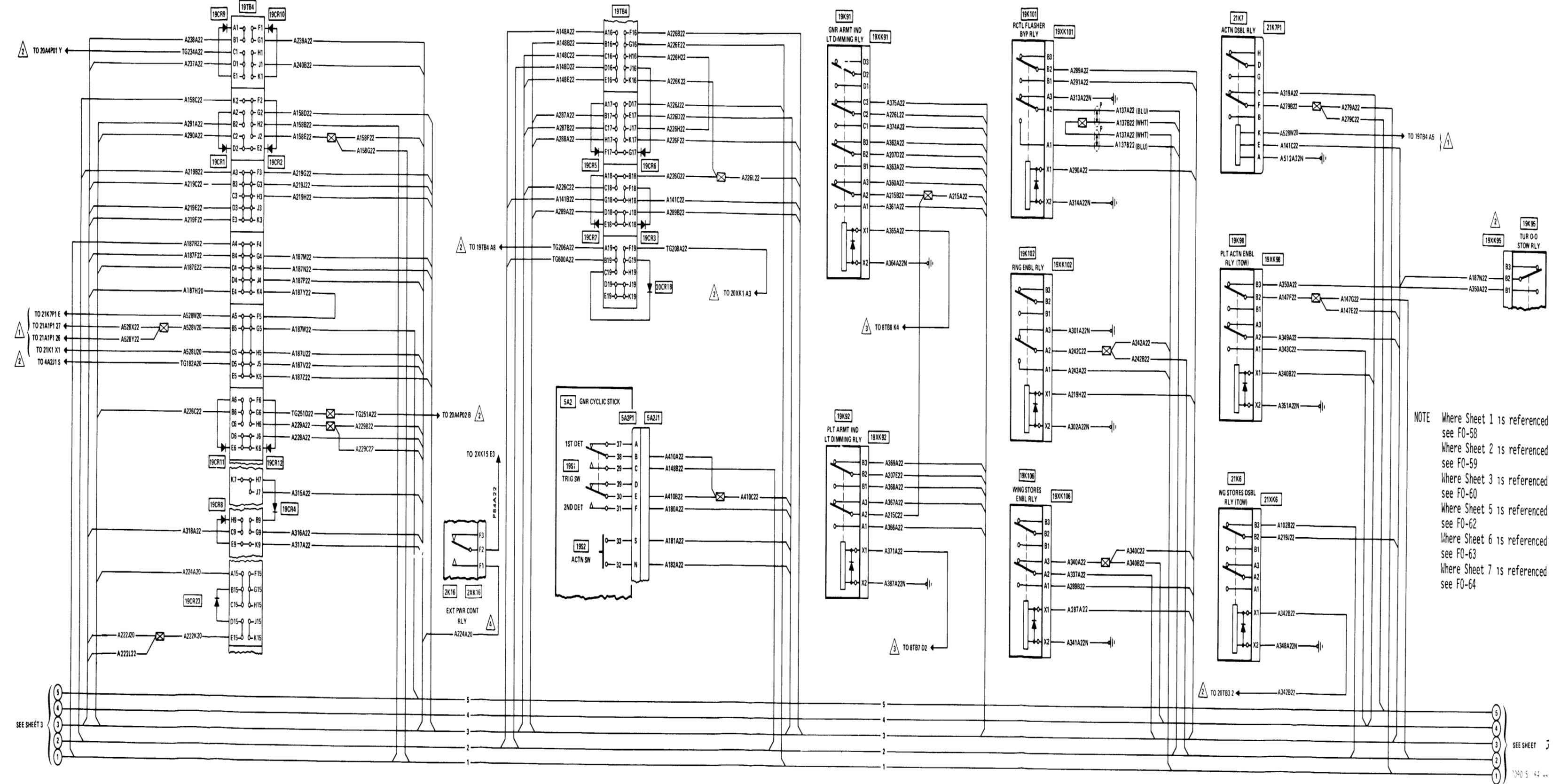

NOTE Where Sheet 1 is referenced see FO-58  
 Where Sheet 2 is referenced see FO-59  
 Where Sheet 3 is referenced see FO-60  
 Where Sheet 5 is referenced see FO-62  
 Where Sheet 6 is referenced see FO-63  
 Where Sheet 7 is referenced see FO-64

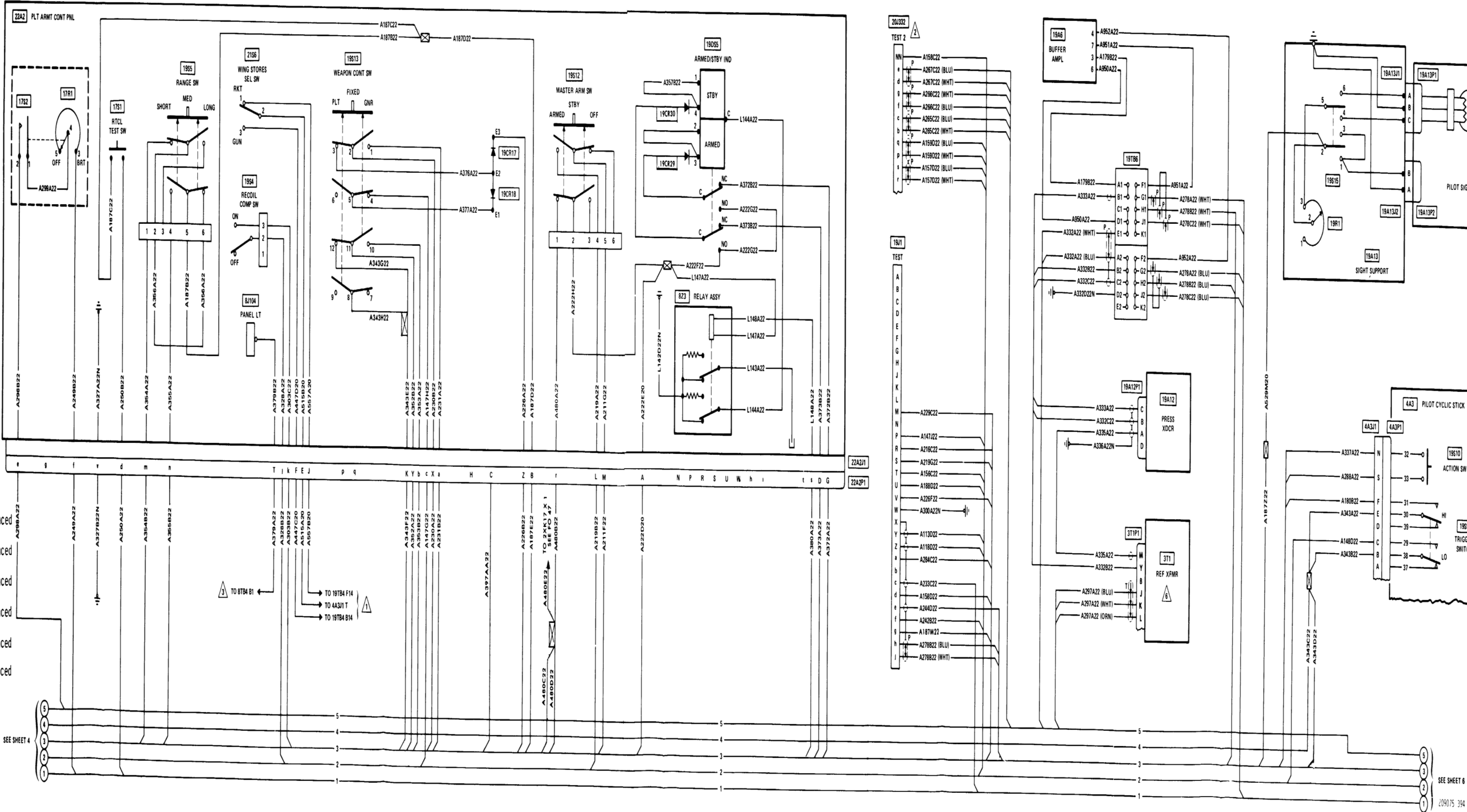

NOTE Where Sheet 1 is referenced see FO-58  
 Where Sheet 2 is referenced see FO-59  
 Where Sheet 3 is referenced see FO-60  
 Where Sheet 4 is referenced see FO-61  
 Where Sheet 6 is referenced see FO-63  
 Where Sheet 7 is referenced see FO-64



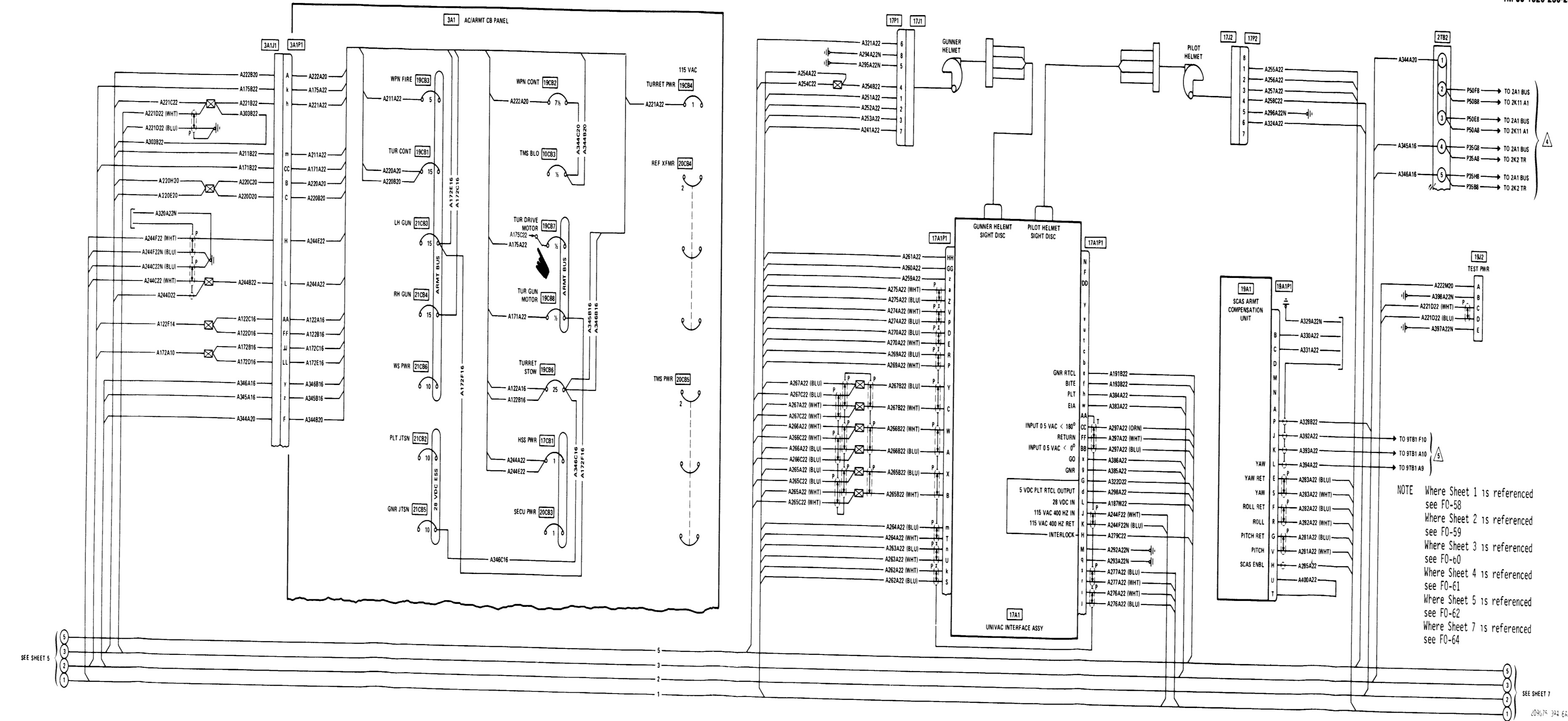

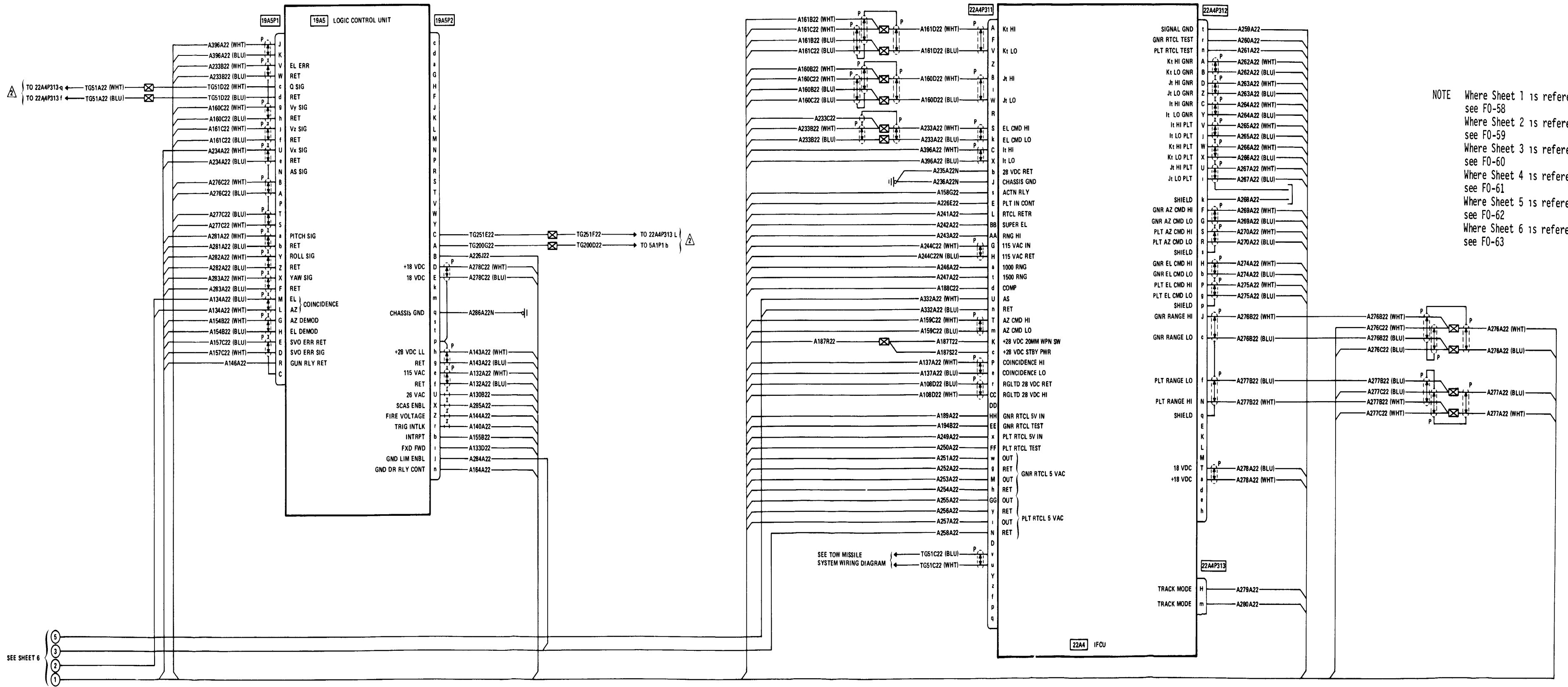

NOTE Where Sheet 1 is referenced see FO-58  
 Where Sheet 2 is referenced see FO-59  
 Where Sheet 3 is referenced see FO-60  
 Where Sheet 4 is referenced see FO-61  
 Where Sheet 5 is referenced see FO-62  
 Where Sheet 6 is referenced see FO-63

- NOTES
- SEE WING STORES SYSTEM WIRING DIAGRAM
  - SEE TOW MISSILE SYSTEM WIRING DIAGRAM
  - SEE INTERIOR LIGHTS SYSTEM WIRING DIAGRAM
  - SEE DC POWER DISTRIBUTION AND CONTROL LOGIC WIRING DIAGRAM
  - SEE TM 11 1520 236 20
  - SEE AC POWER SYSTEM WIRING DIAGRAM



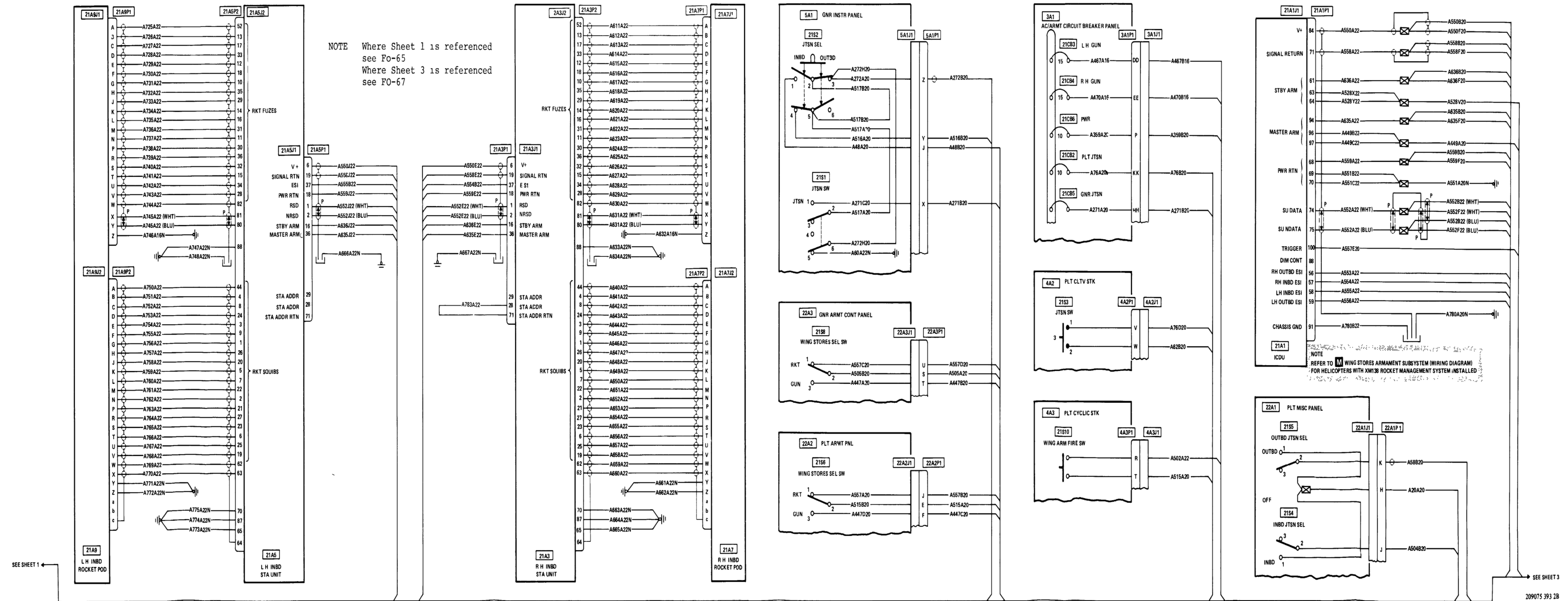

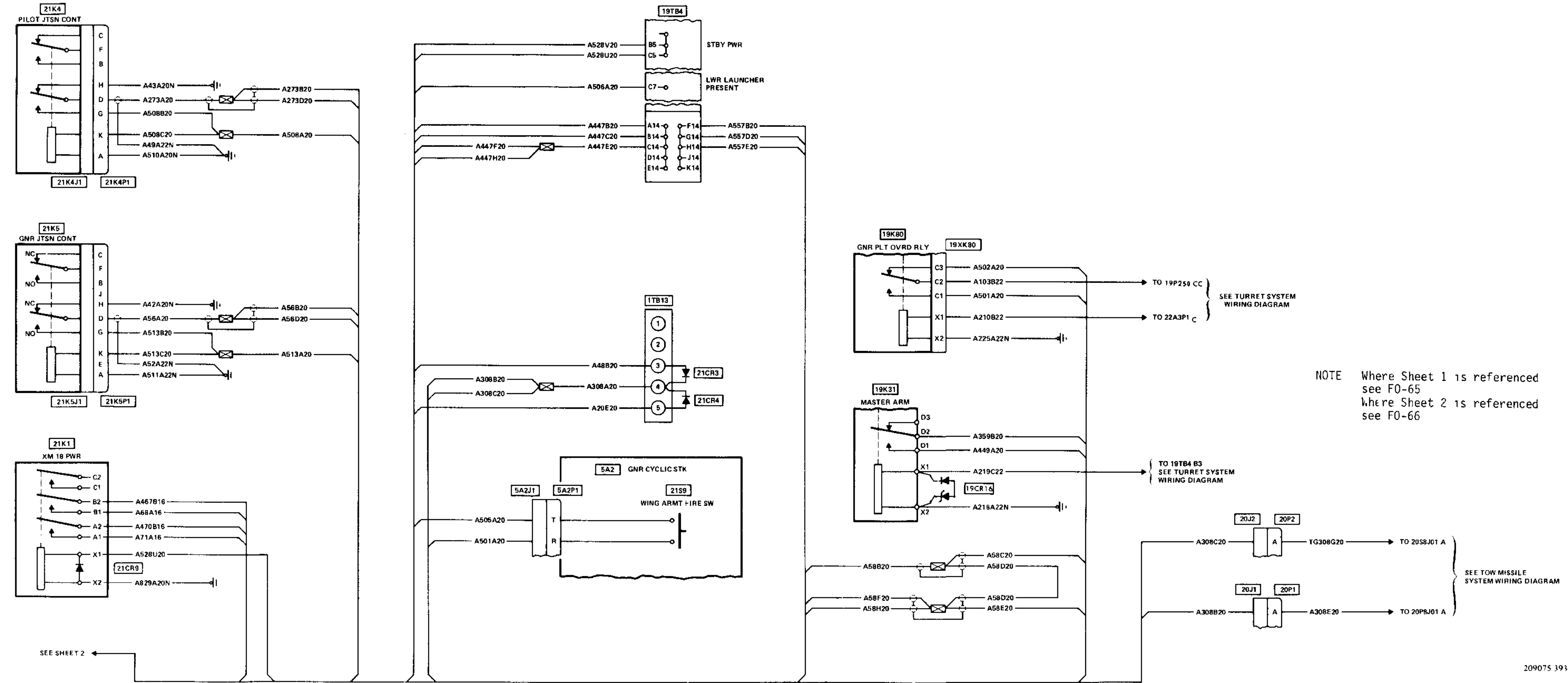

NOTE  
 Where Sheet 2 is referenced  
 see FO-69  
 Where Sheet 3 is referenced  
 see FO-70  
 Where Sheet 4 is referenced  
 see FO-71.  
 Where Sheet 5 is referenced  
 see FO-72  
 Where Sheet 6 is referenced  
 see FO-73  
 Where Sheet 7 is referenced  
 see FO-74  
 Where Sheet 8 is referenced  
 see FO-75  
 Where Sheet 9 is referenced  
 see FO-76  
 Where Sheet 10 is referenced  
 see FO-77

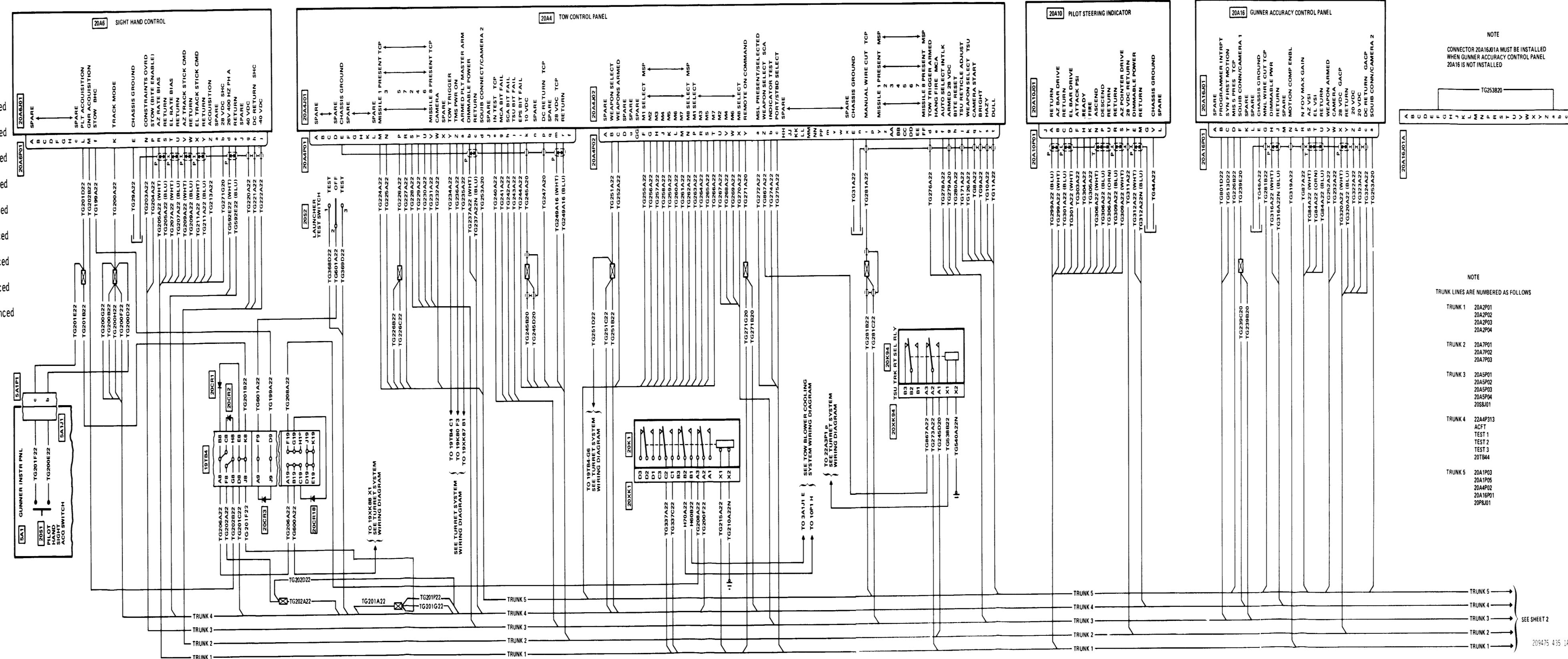

NOTE  
 CONNECTOR 20416A10A MUST BE INSTALLED  
 WHEN GUNNER ACCURACY CONTROL PANEL  
 20416 IS NOT INSTALLED

NOTE  
 TRUNK LINES ARE NUMBERED AS FOLLOWS

- TRUNK 1 2042P01  
2042P02  
2042P03  
2042P04
- TRUNK 2 2041P01  
2041P02  
2041P03  
2041P04
- TRUNK 3 2043P01  
2043P02  
2043P03  
2043P04  
2065J01
- TRUNK 4 2244P13  
ACT  
TEST 1  
TEST 2  
TEST 3  
207B4
- TRUNK 5 2041P03  
2041P05  
2041P02  
2041P01  
20P8J01

TRUNK 5  
 TRUNK 4  
 TRUNK 3  
 TRUNK 2  
 TRUNK 1

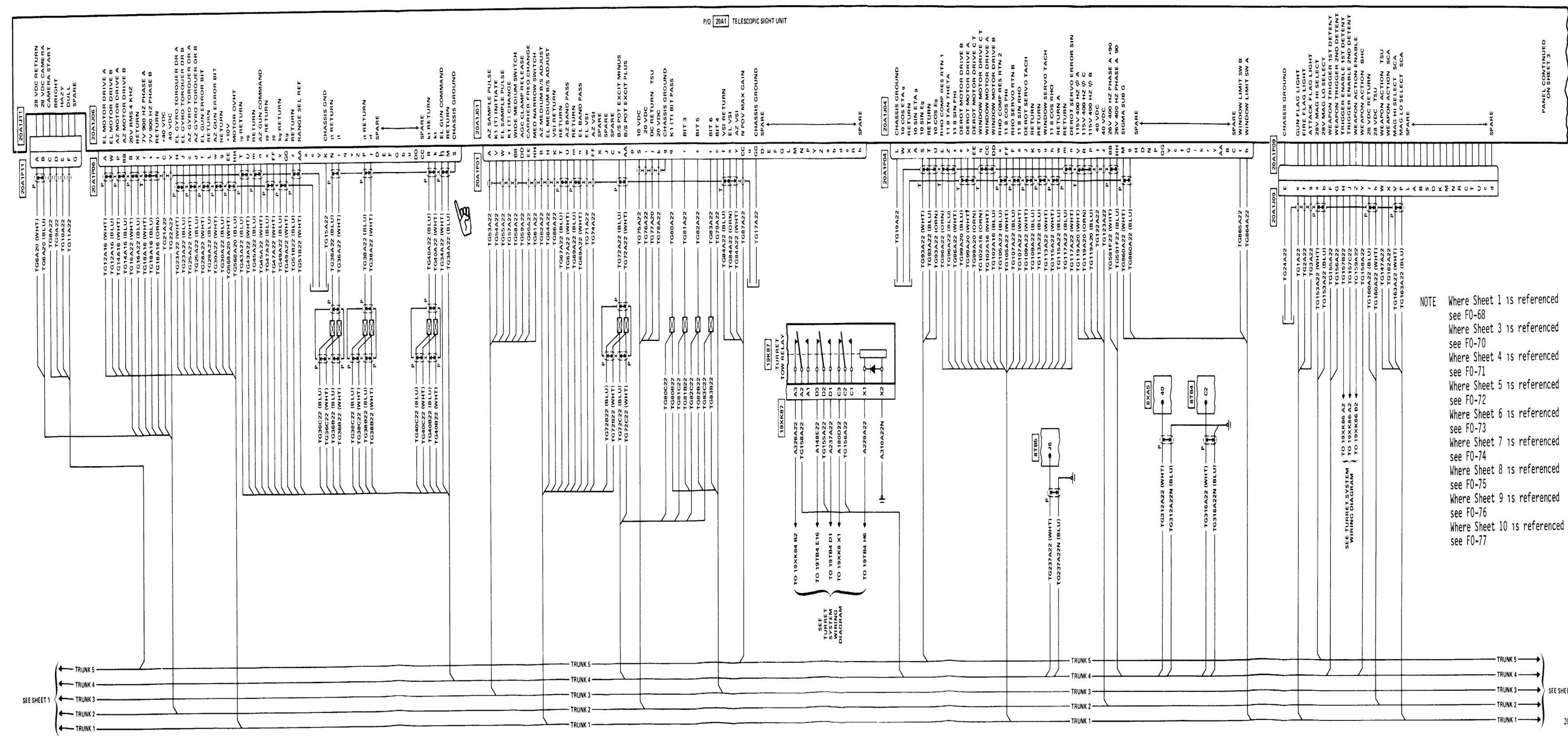

NOTE Where Sheet 1 is referenced see FO-68  
 Where Sheet 3 is referenced see FO-70  
 Where Sheet 4 is referenced see FO-71  
 Where Sheet 5 is referenced see FO-72  
 Where Sheet 6 is referenced see FO-73  
 Where Sheet 7 is referenced see FO-74  
 Where Sheet 8 is referenced see FO-75  
 Where Sheet 9 is referenced see FO-76  
 Where Sheet 10 is referenced see FO-77

NOTE  
 Where Sheet 1 is referenced see FO-68.  
 Where Sheet 2 is referenced see FO-69.  
 Where Sheet 4 is referenced see FO-71.  
 Where Sheet 5 is referenced see FO-72.  
 Where Sheet 6 is referenced see FO-73.  
 Where Sheet 7 is referenced see FO-74.  
 Where Sheet 8 is referenced see FO-75.  
 Where Sheet 9 is referenced see FO-76.  
 Where Sheet 10 is referenced see FO-77.

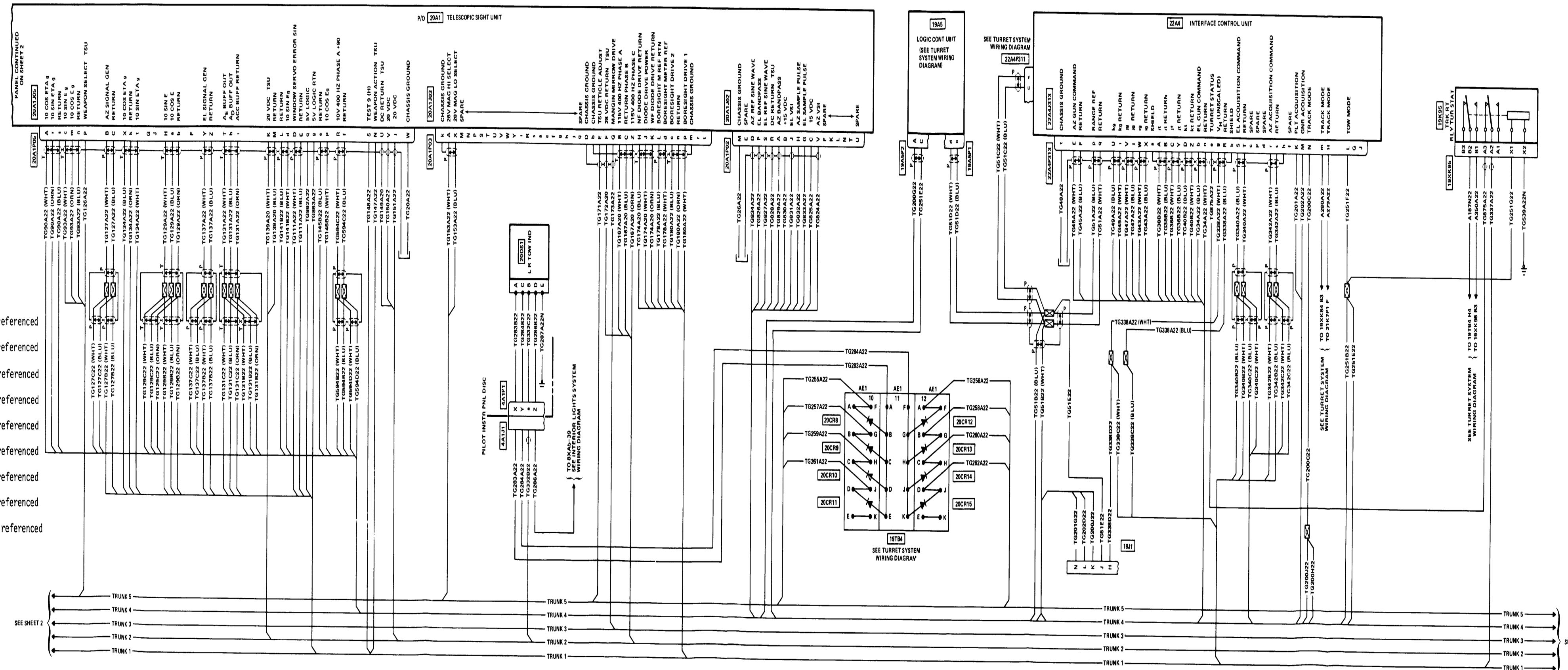



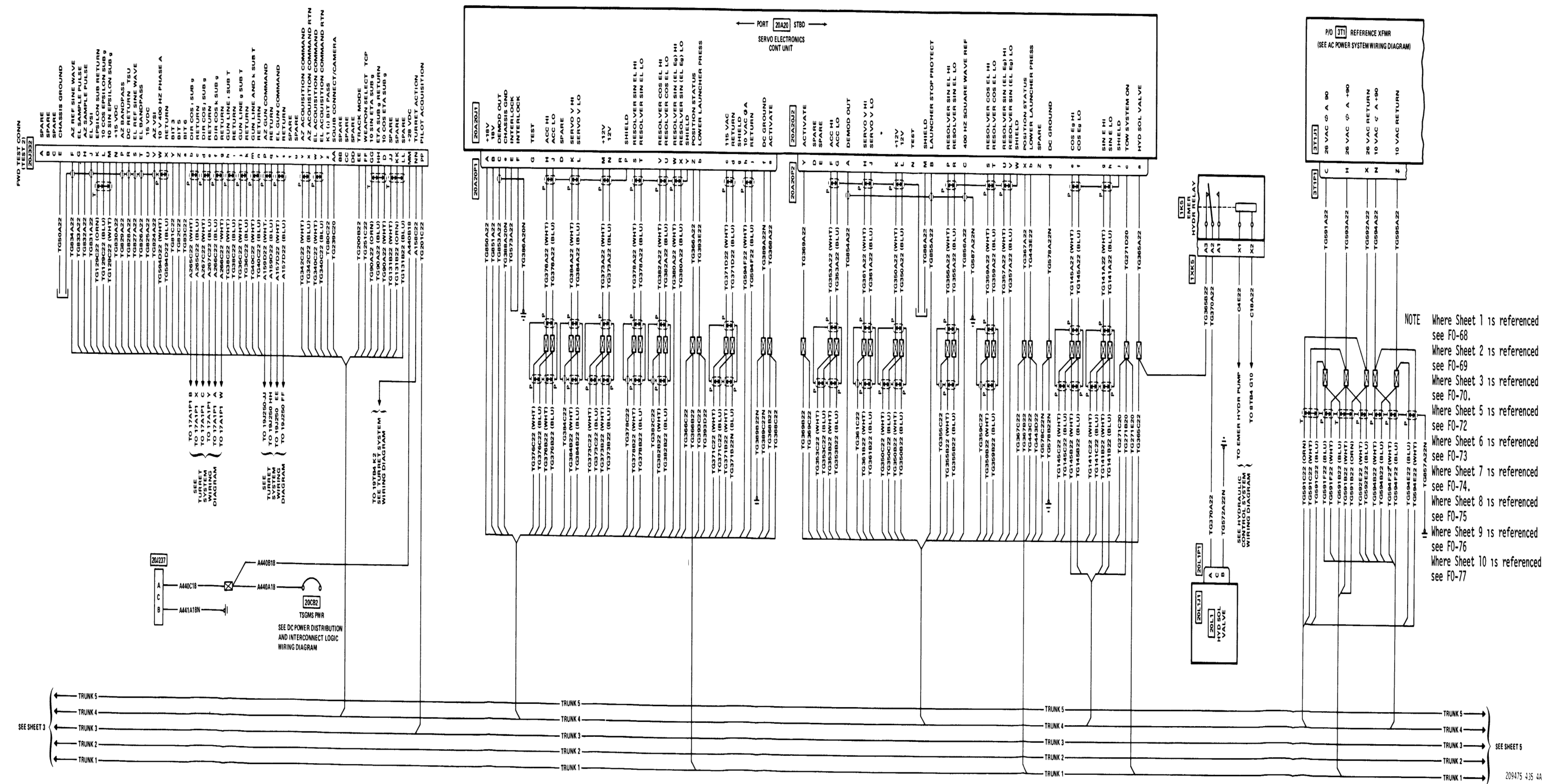

NOTE Where Sheet 1 is referenced see FO-68  
 Where Sheet 2 is referenced see FO-69  
 Where Sheet 3 is referenced see FO-70  
 Where Sheet 5 is referenced see FO-72  
 Where Sheet 6 is referenced see FO-73  
 Where Sheet 7 is referenced see FO-74  
 Where Sheet 8 is referenced see FO-75  
 Where Sheet 9 is referenced see FO-76  
 Where Sheet 10 is referenced see FO-77

NOTE  
 Where Sheet 1 is referenced see FO-68  
 Where Sheet 2 is referenced see FO-69  
 Where Sheet 3 is referenced see FO-70  
 Where Sheet 4 is referenced see FO-71  
 Where Sheet 6 is referenced see FO-73  
 Where Sheet 7 is referenced see FO-74  
 Where Sheet 8 is referenced see FO-75  
 Where Sheet 9 is referenced see FO-76  
 Where Sheet 10 is referenced see FO-77

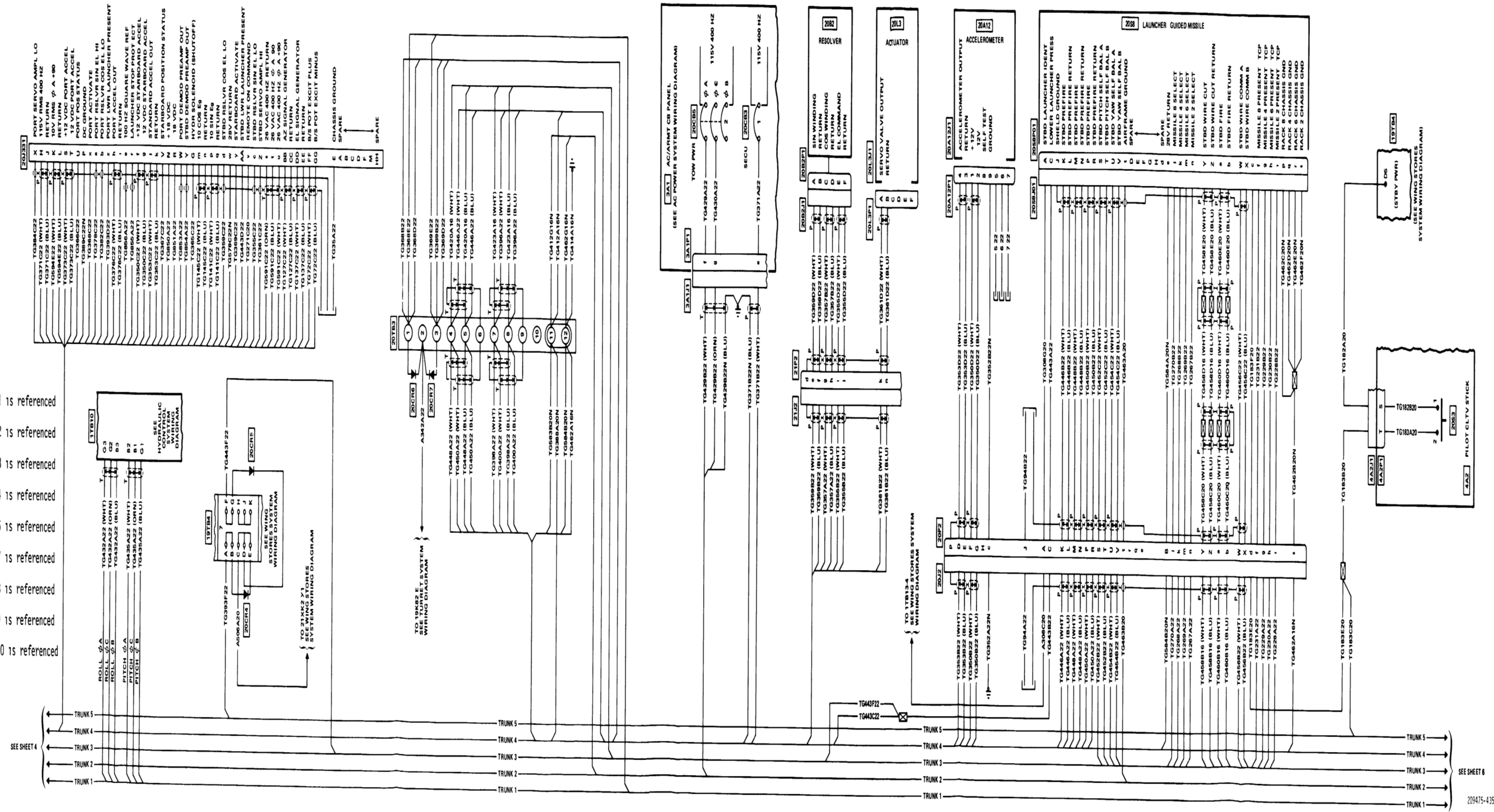

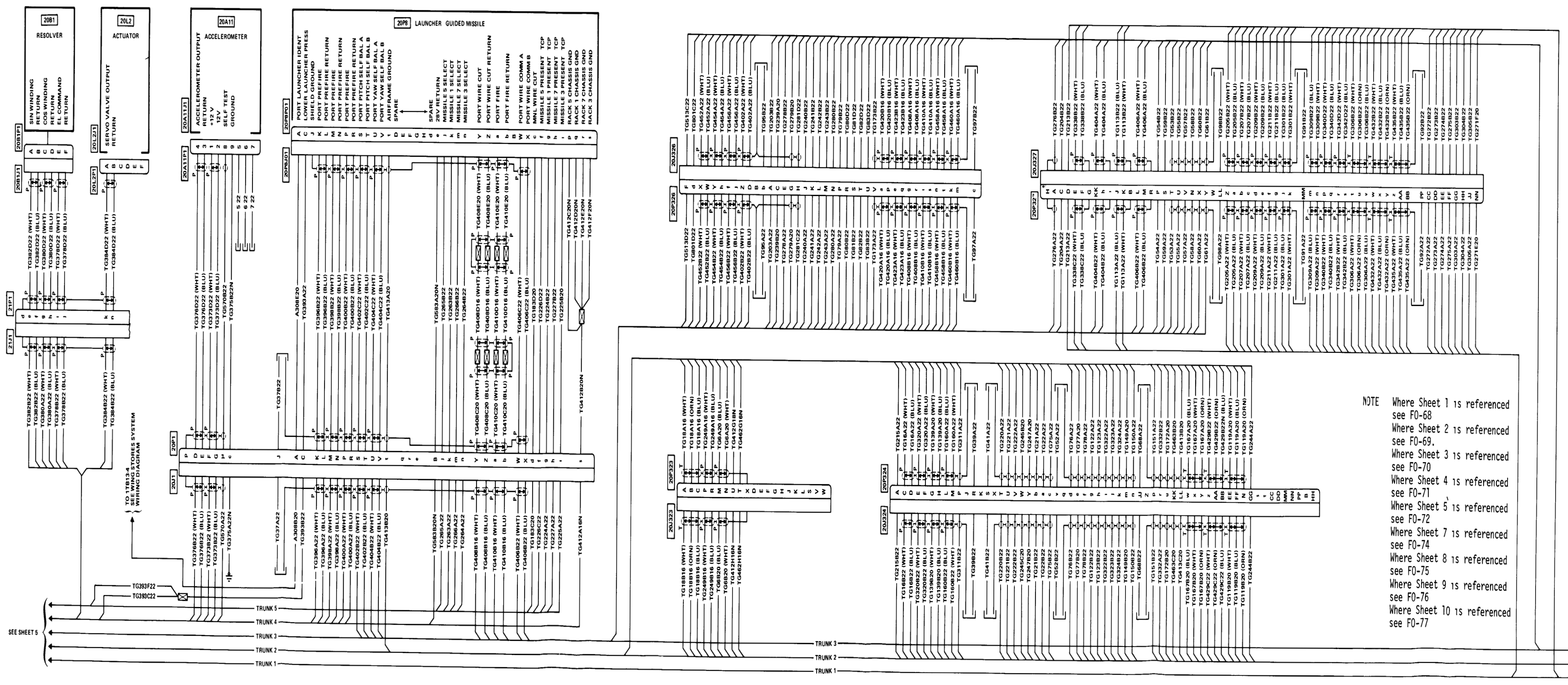

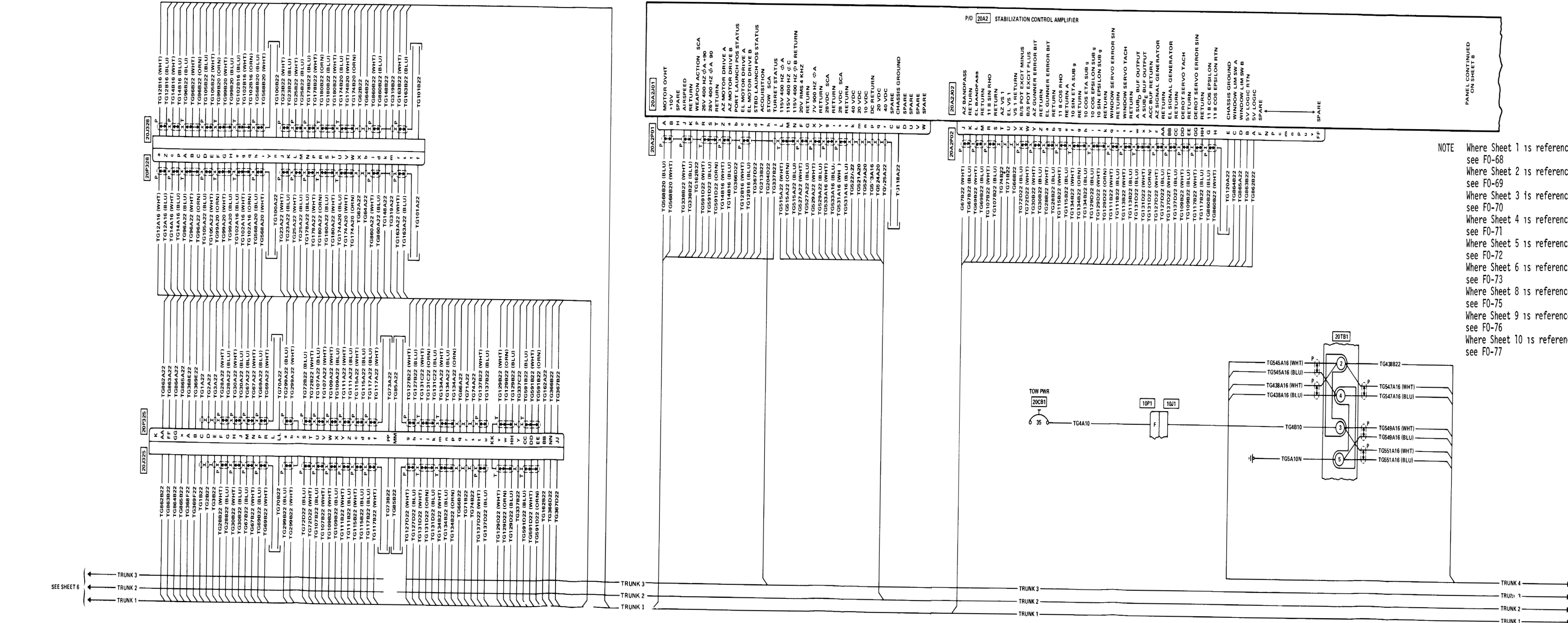

NOTE: Where Sheet 1 is referenced see FO-68; Where Sheet 2 is referenced see FO-69; Where Sheet 3 is referenced see FO-70; Where Sheet 4 is referenced see FO-71; Where Sheet 5 is referenced see FO-72; Where Sheet 6 is referenced see FO-73; Where Sheet 8 is referenced see FO-75; Where Sheet 9 is referenced see FO-76; Where Sheet 10 is referenced see FO-77.

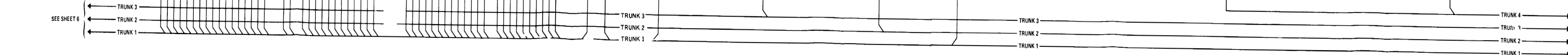



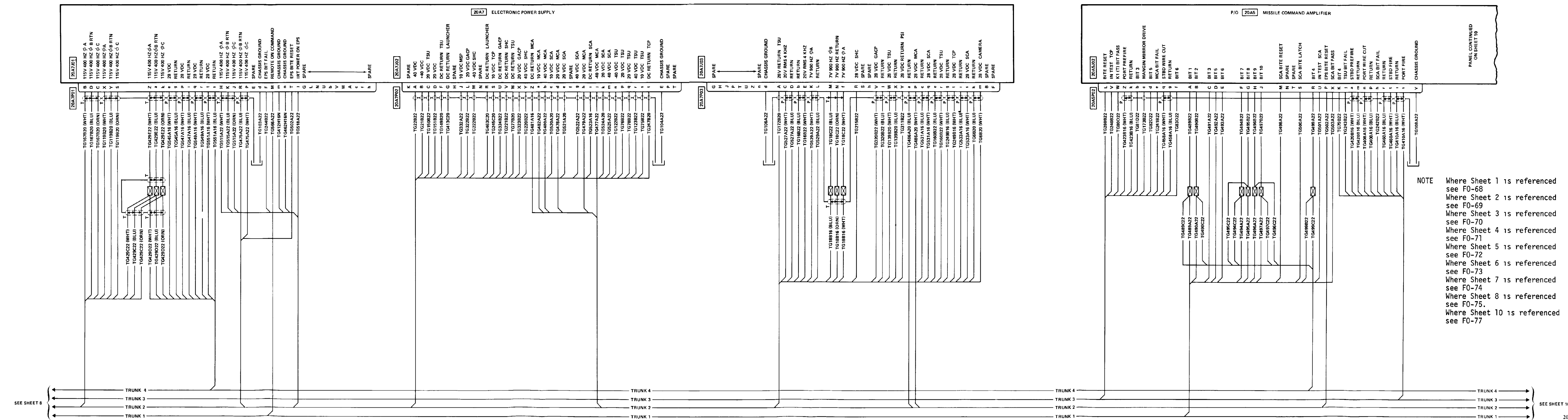

PANEL CONTINUED ON SHEET 10

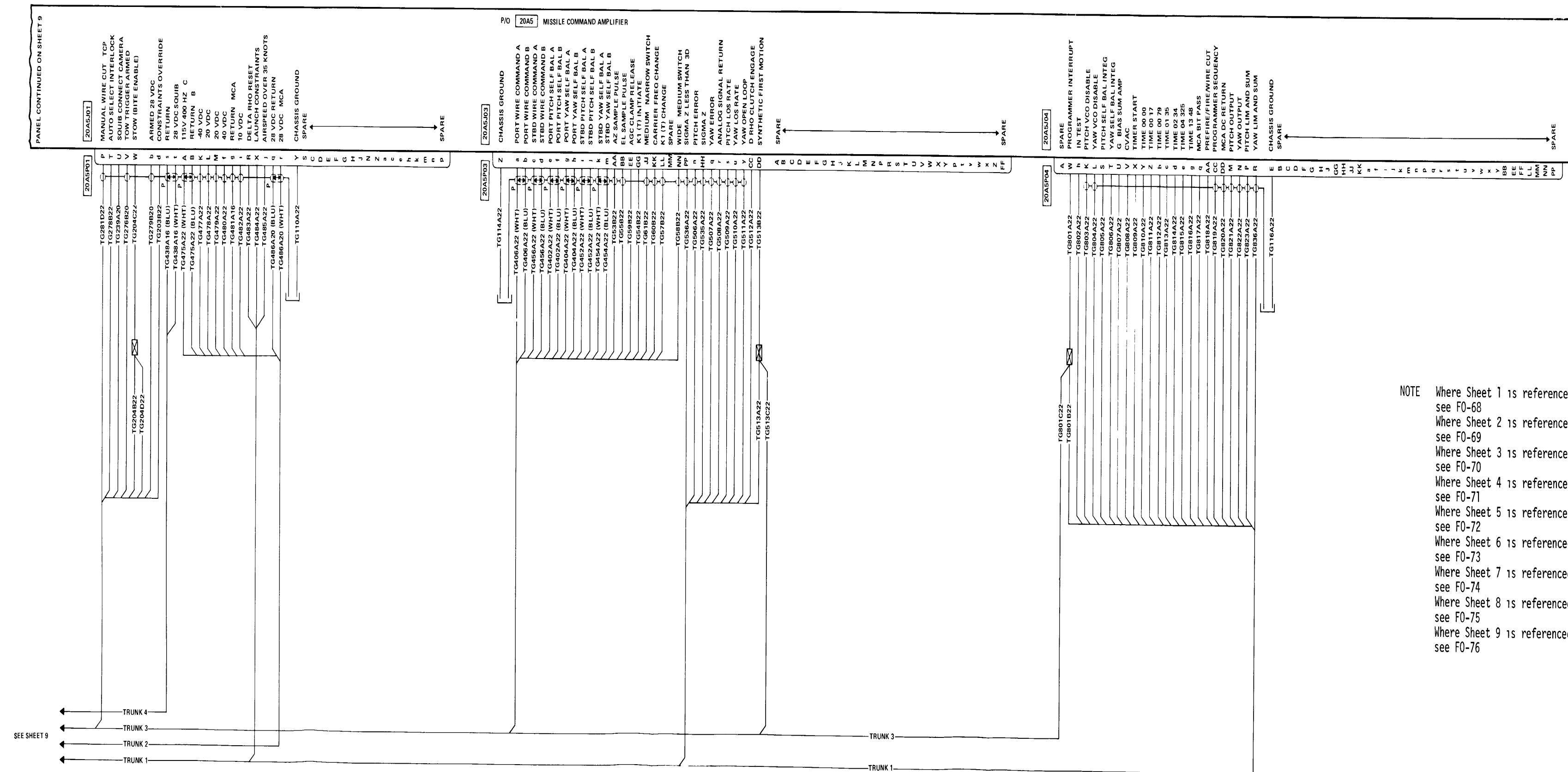

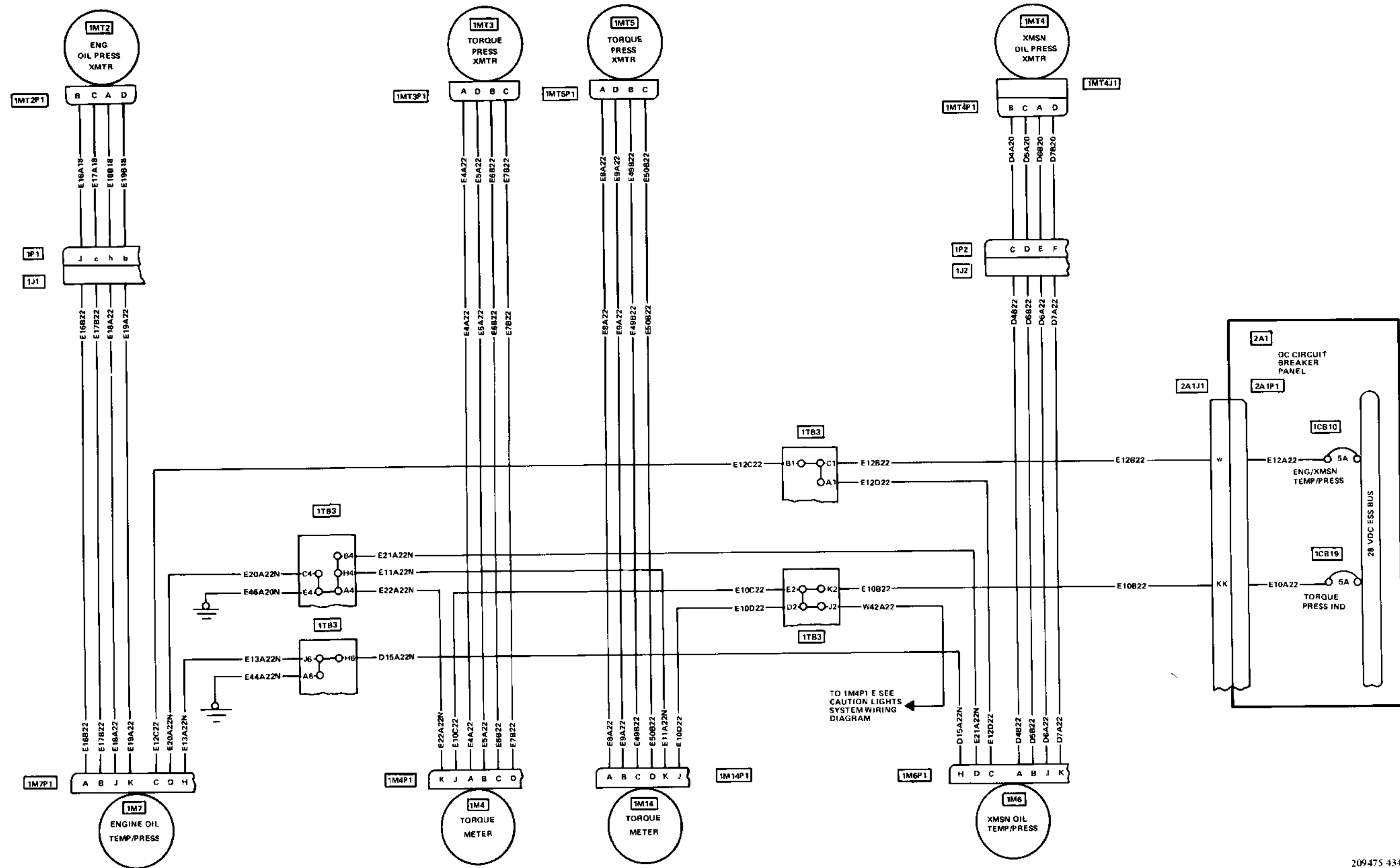



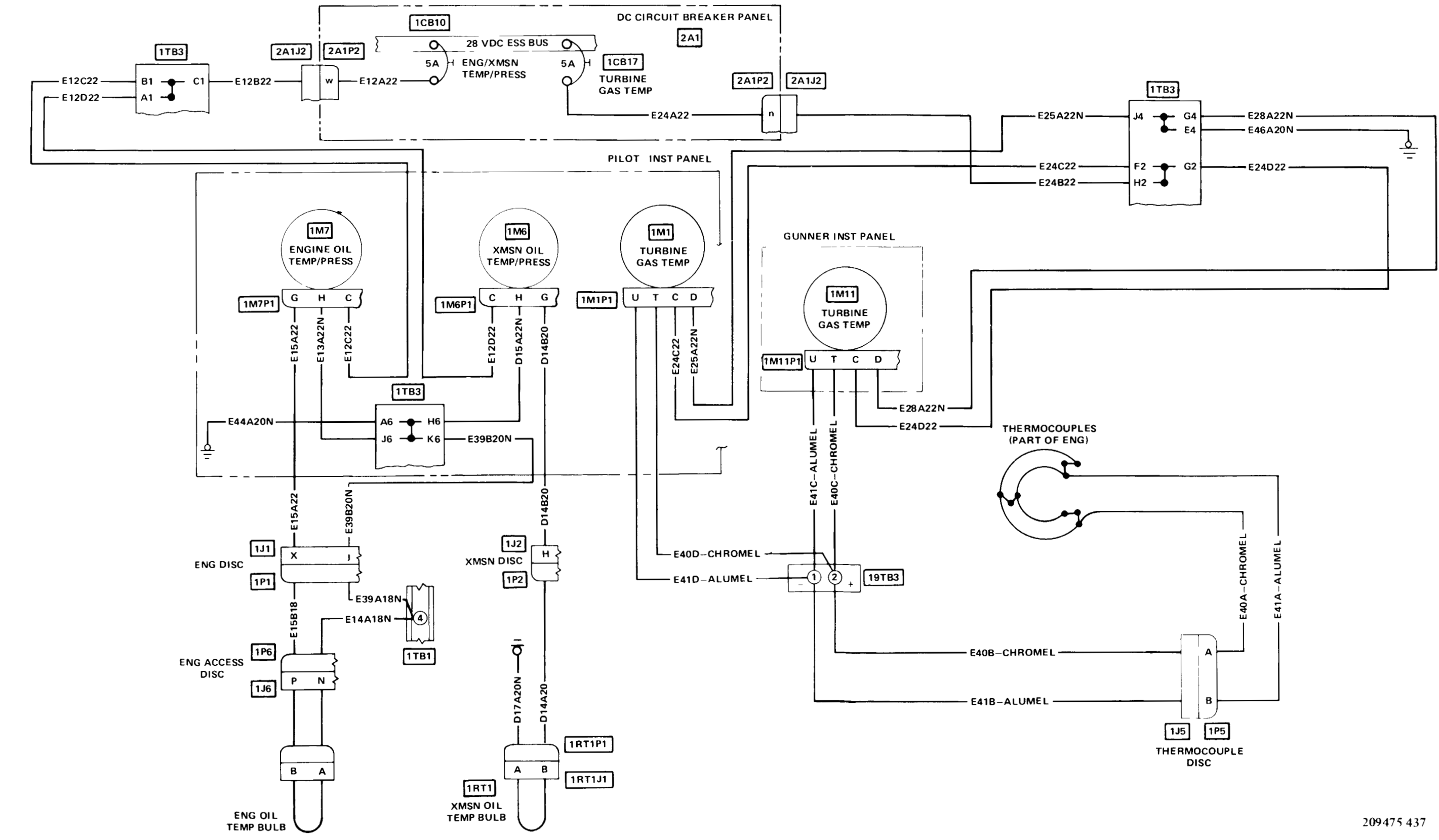

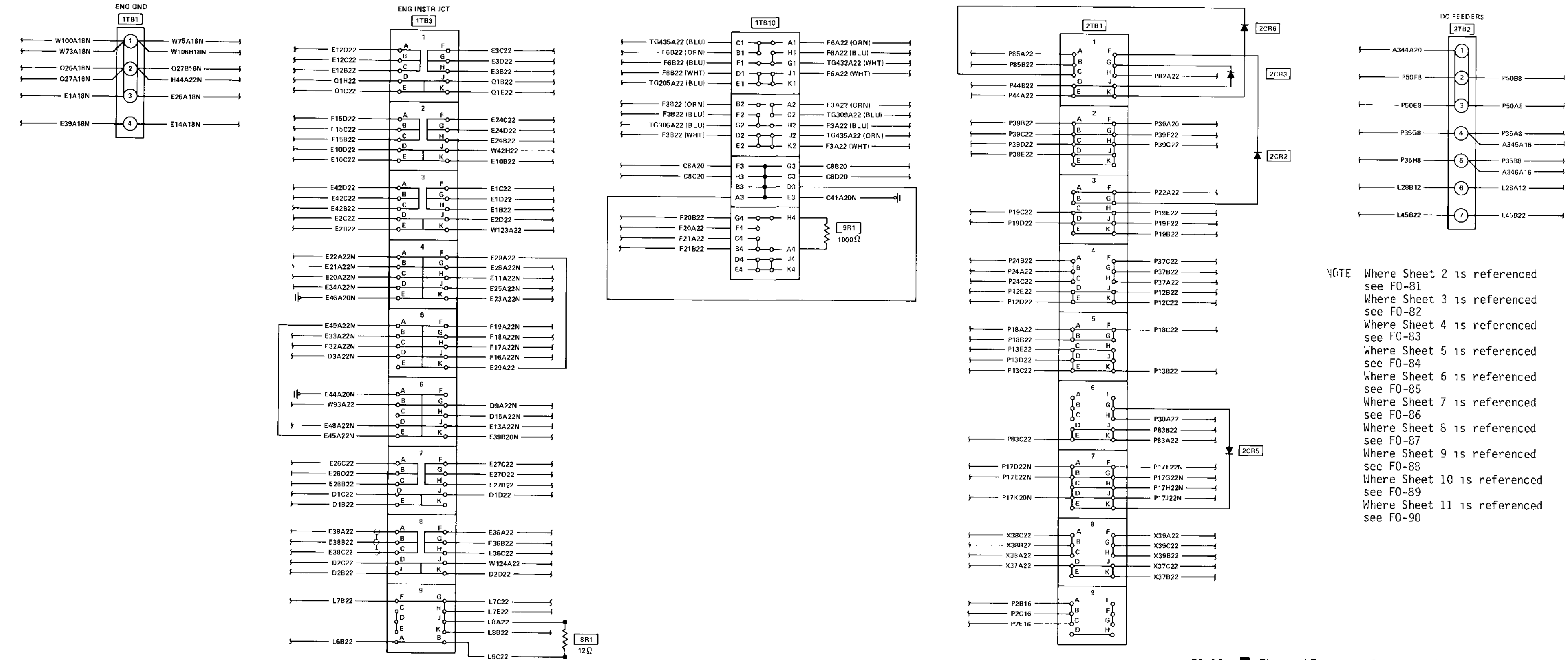

NOTE Where Sheet 2 is referenced see FO-81  
 Where Sheet 3 is referenced see FO-82  
 Where Sheet 4 is referenced see FO-83  
 Where Sheet 5 is referenced see FO-84  
 Where Sheet 6 is referenced see FO-85  
 Where Sheet 7 is referenced see FO-86  
 Where Sheet 8 is referenced see FO-87  
 Where Sheet 9 is referenced see FO-88  
 Where Sheet 10 is referenced see FO-89  
 Where Sheet 11 is referenced see FO-90

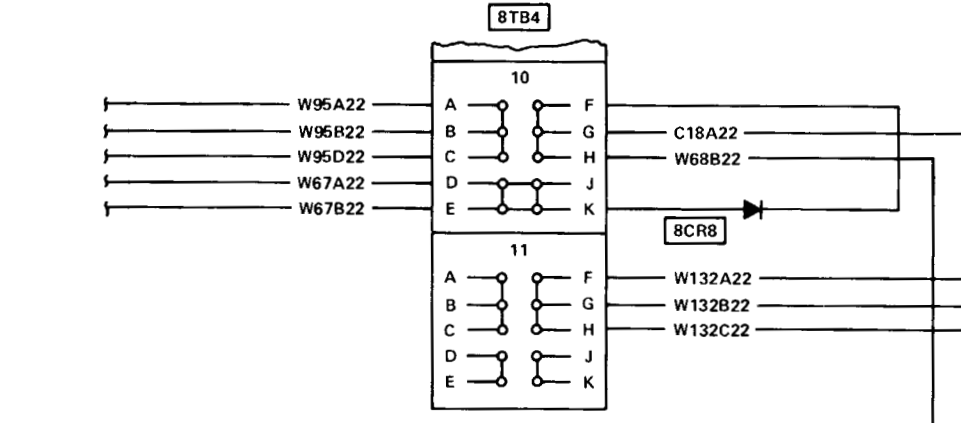
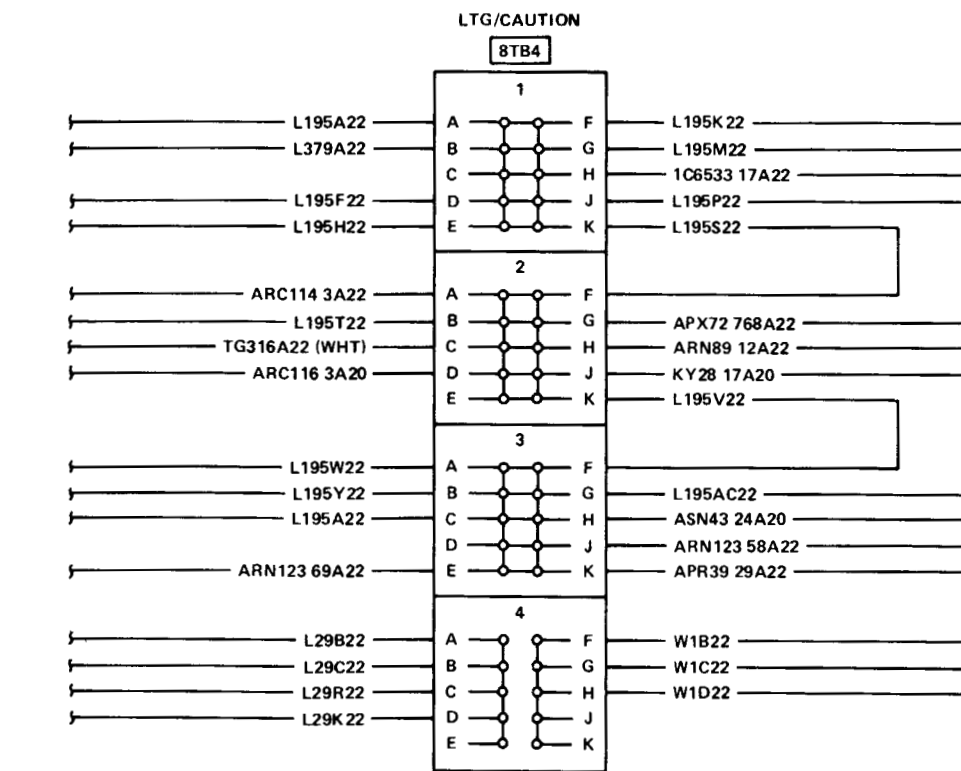
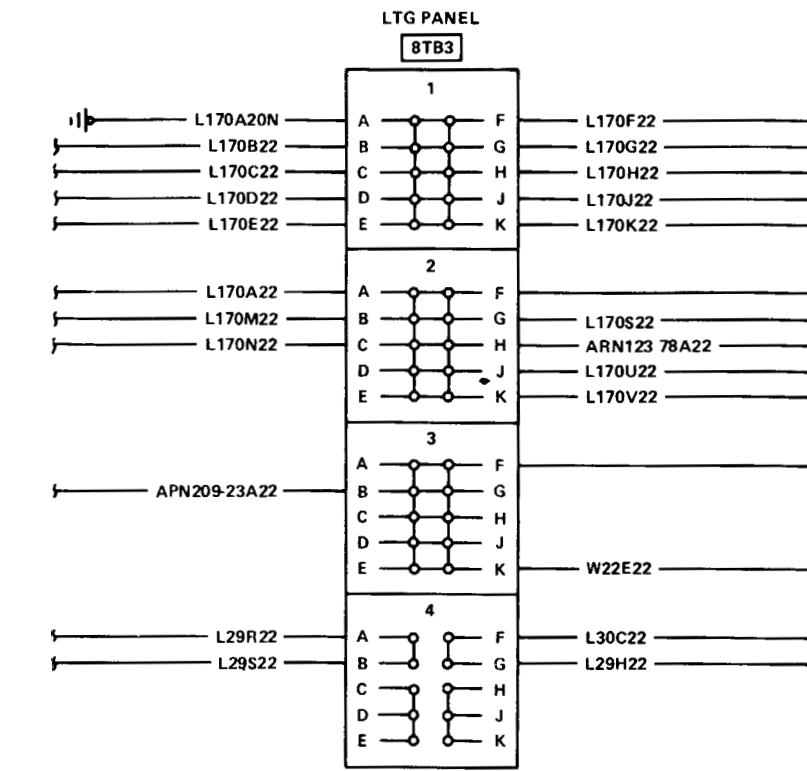

NOTE Where Sheet 1 is referenced see F0-80  
 Where Sheet 3 is referenced see F0-82  
 Where Sheet 4 is referenced see F0-83  
 Where Sheet 5 is referenced see F0-84  
 Where Sheet 6 is referenced see F0-85  
 Where Sheet 7 is referenced see F0-86  
 Where Sheet 8 is referenced see F0-87  
 Where Sheet 9 is referenced see F0-88  
 Where Sheet 10 is referenced see F0-89  
 Where Sheet 11 is referenced see F0-90

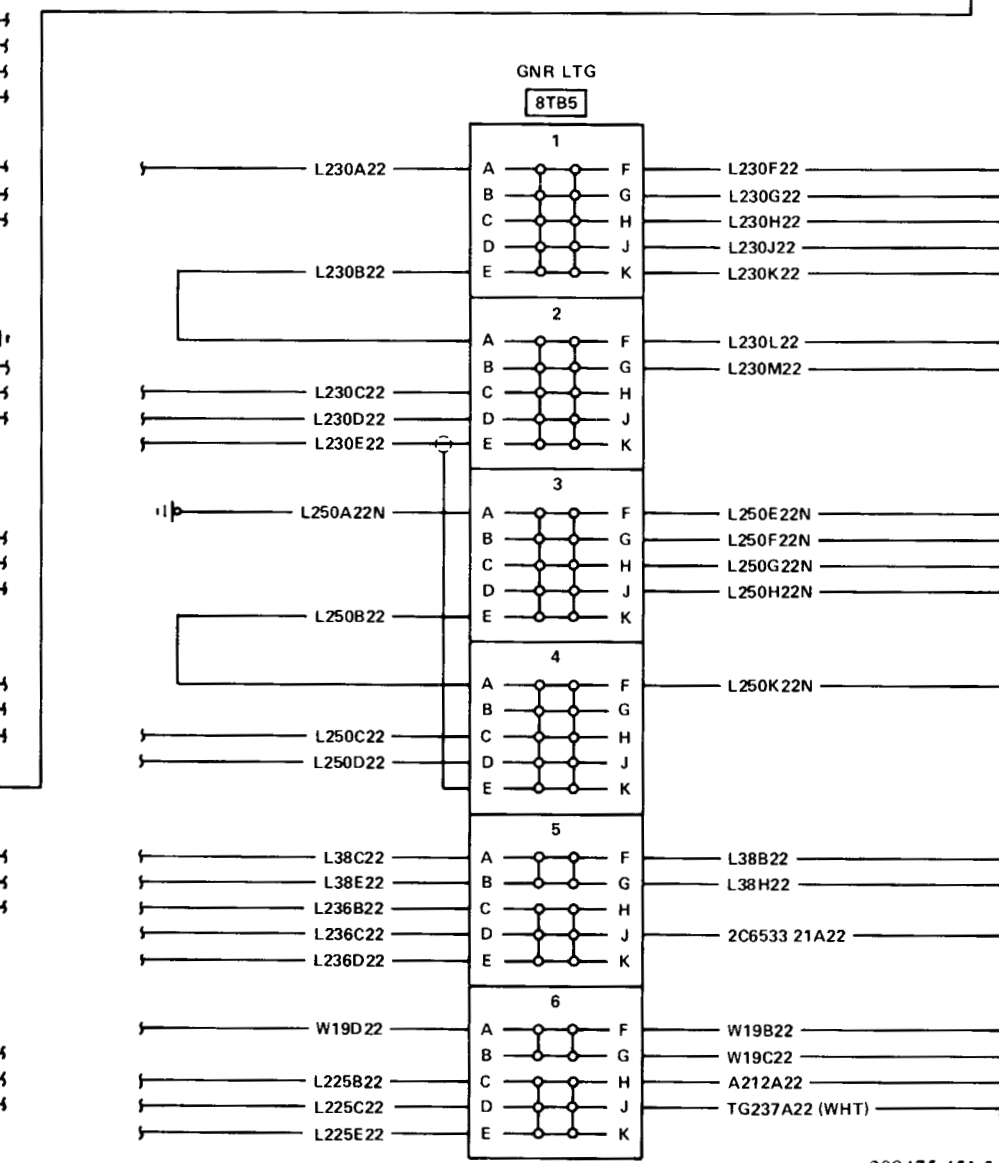
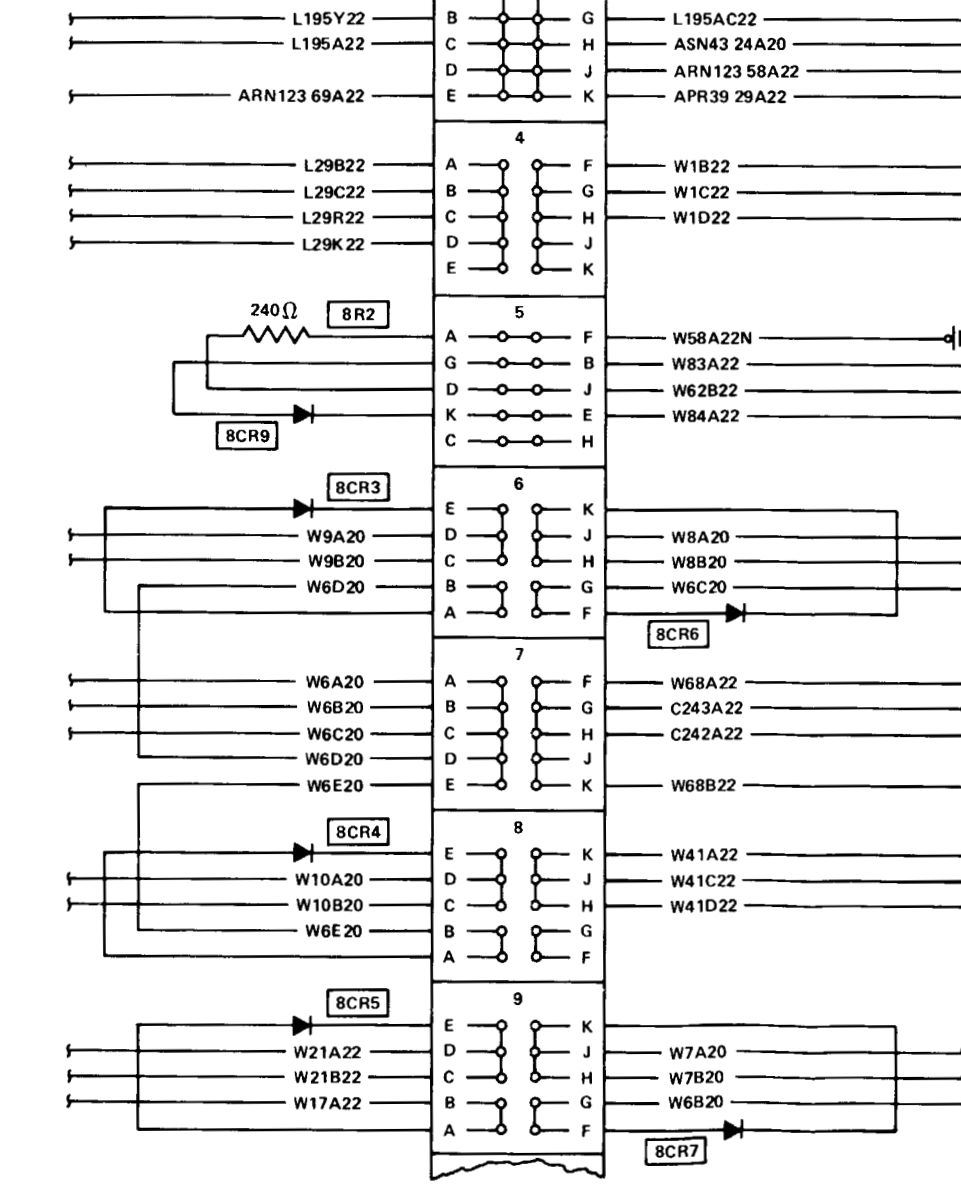

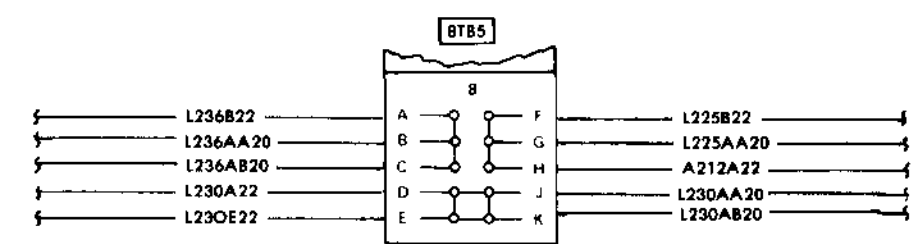
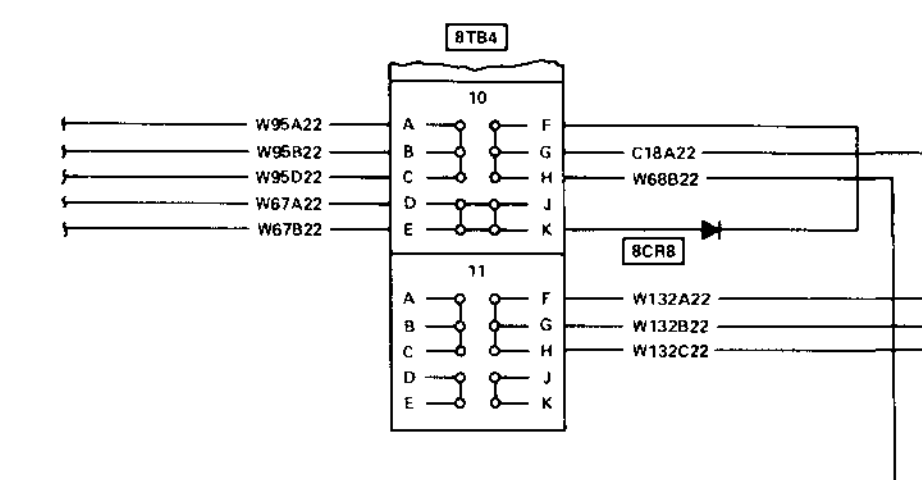
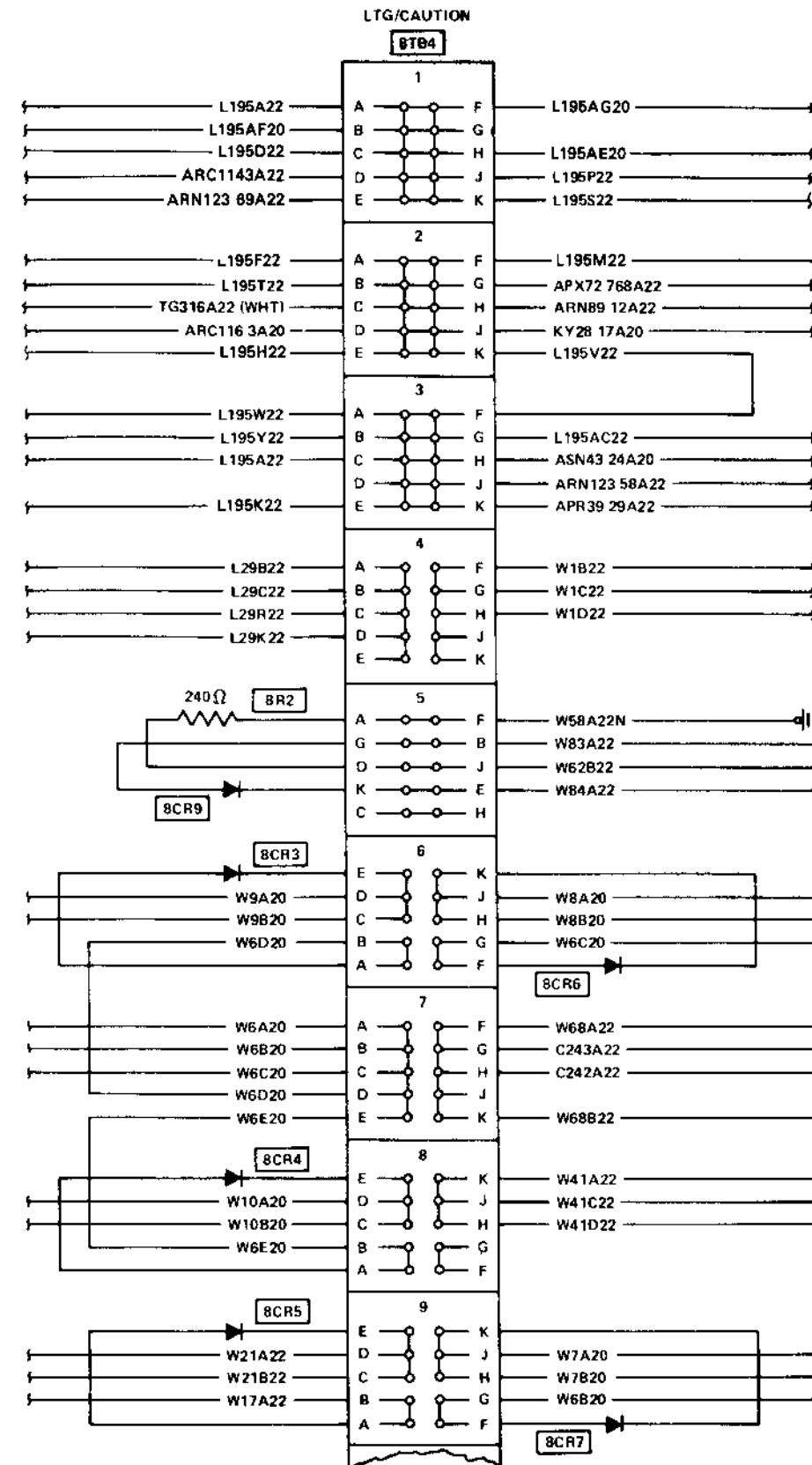
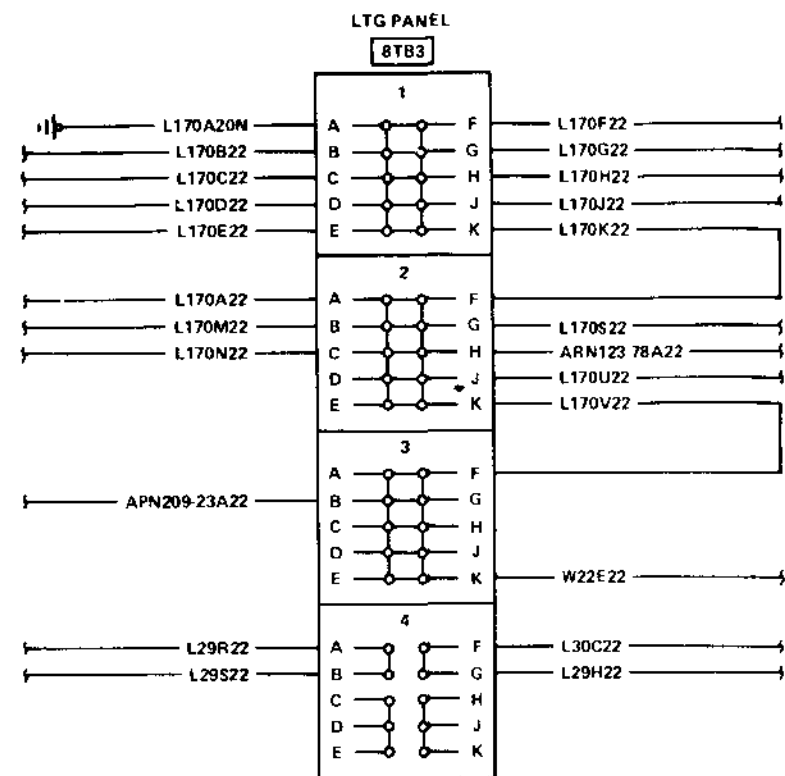

NOTE Where Sheet 1 is referenced see FO-80  
 Where Sheet 3 is referenced see FO-82  
 Where Sheet 4 is referenced see FO-83  
 Where Sheet 5 is referenced see FO-84  
 Where Sheet 6 is referenced see FO-85  
 Where Sheet 7 is referenced see FO-86  
 Where Sheet 8 is referenced see FO-87  
 Where Sheet 9 is referenced see FO-88  
 Where Sheet 10 is referenced see FO-89  
 Where Sheet 11 is referenced see FO-90

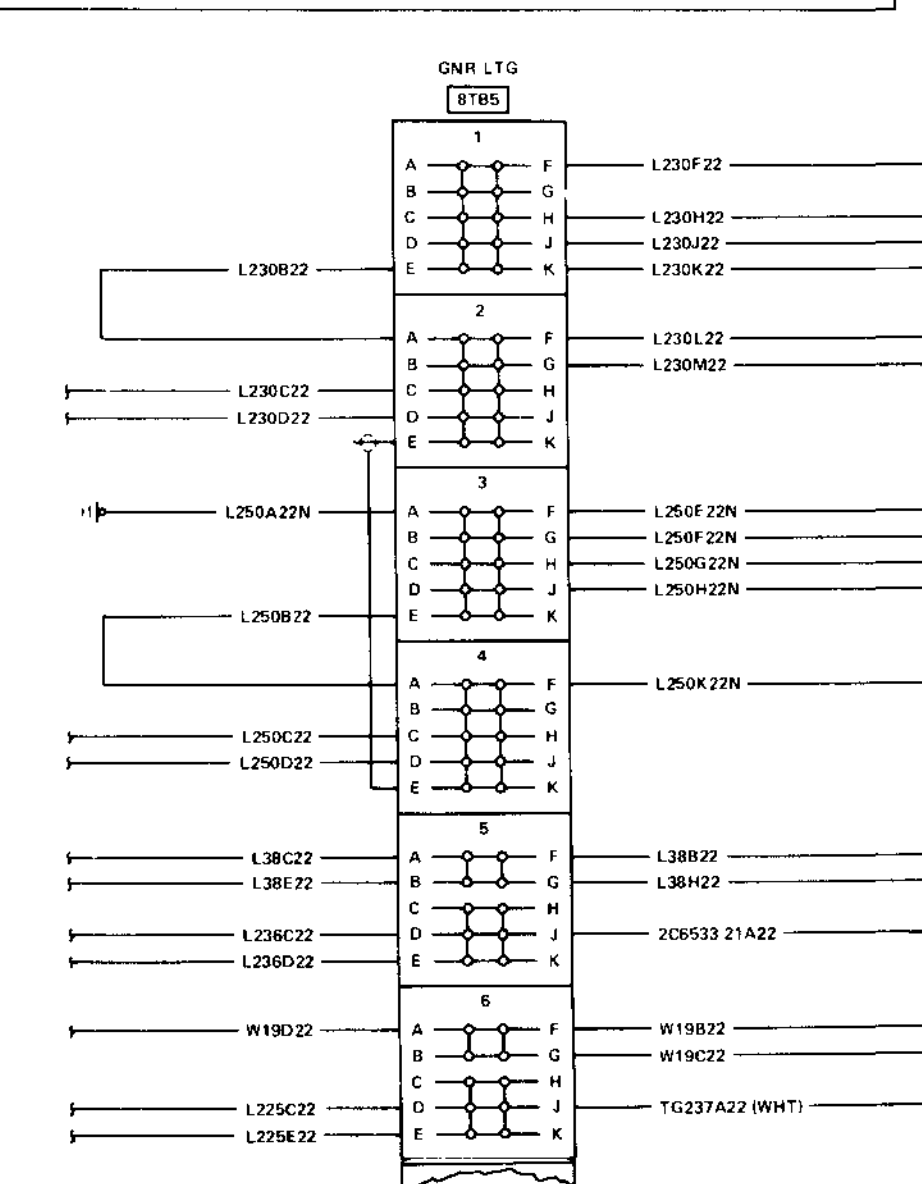

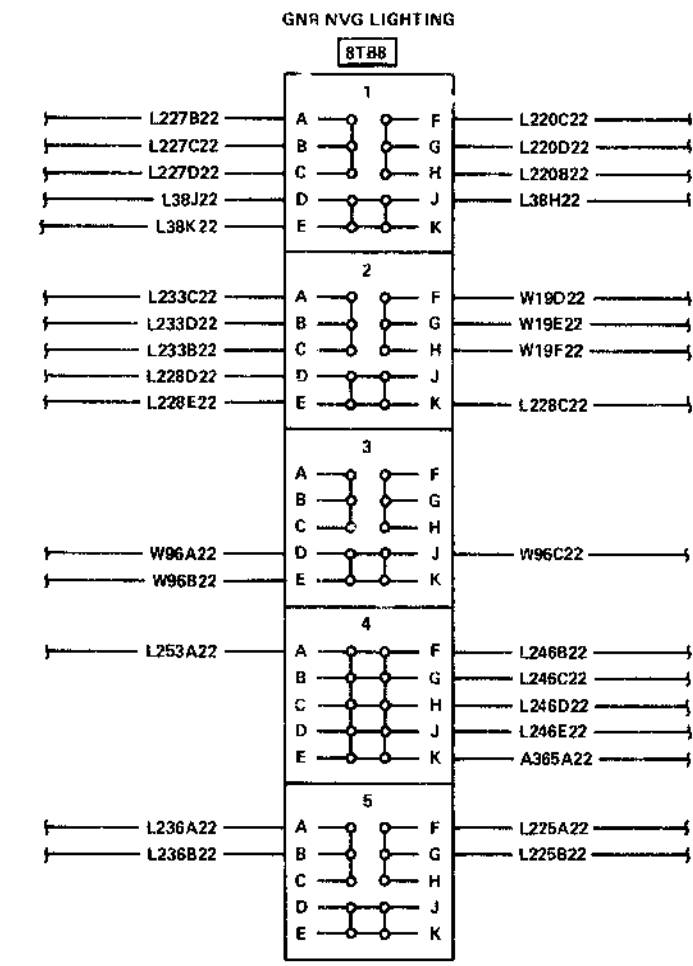
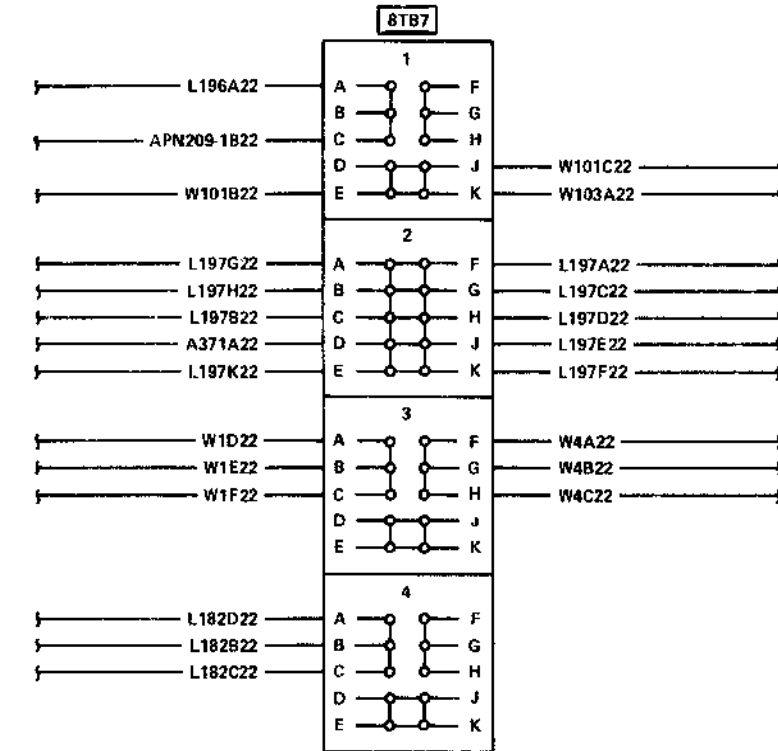
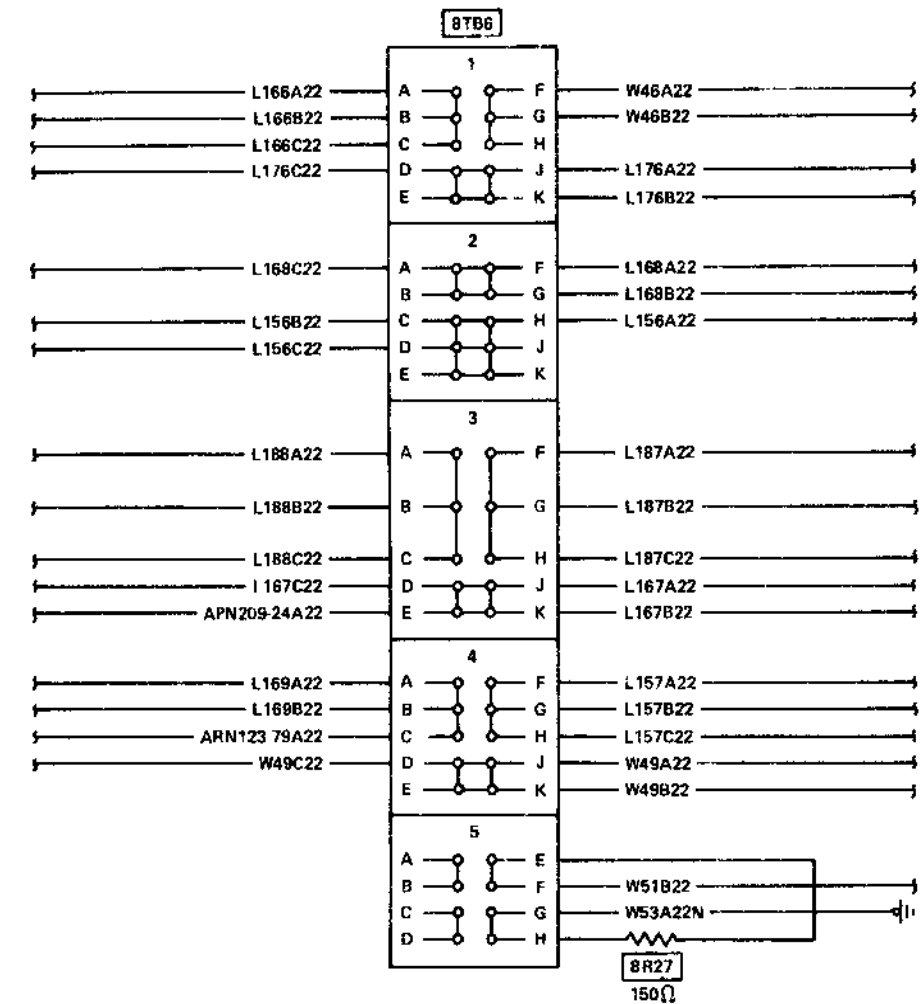

NOTE Where Sheet 1 is referenced see FO 80  
 Where Sheet 2 is referenced see FO 81  
 Where Sheet 4 is referenced see FO 83  
 Where Sheet 5 is referenced see FO 84  
 Where Sheet 6 is referenced see FO 85  
 Where Sheet 7 is referenced see FO 86  
 Where Sheet 8 is referenced see FO 87  
 Where Sheet 9 is referenced see FO-88  
 Where Sheet 10 is referenced see FO 89  
 Where Sheet 11 is referenced see FO 90

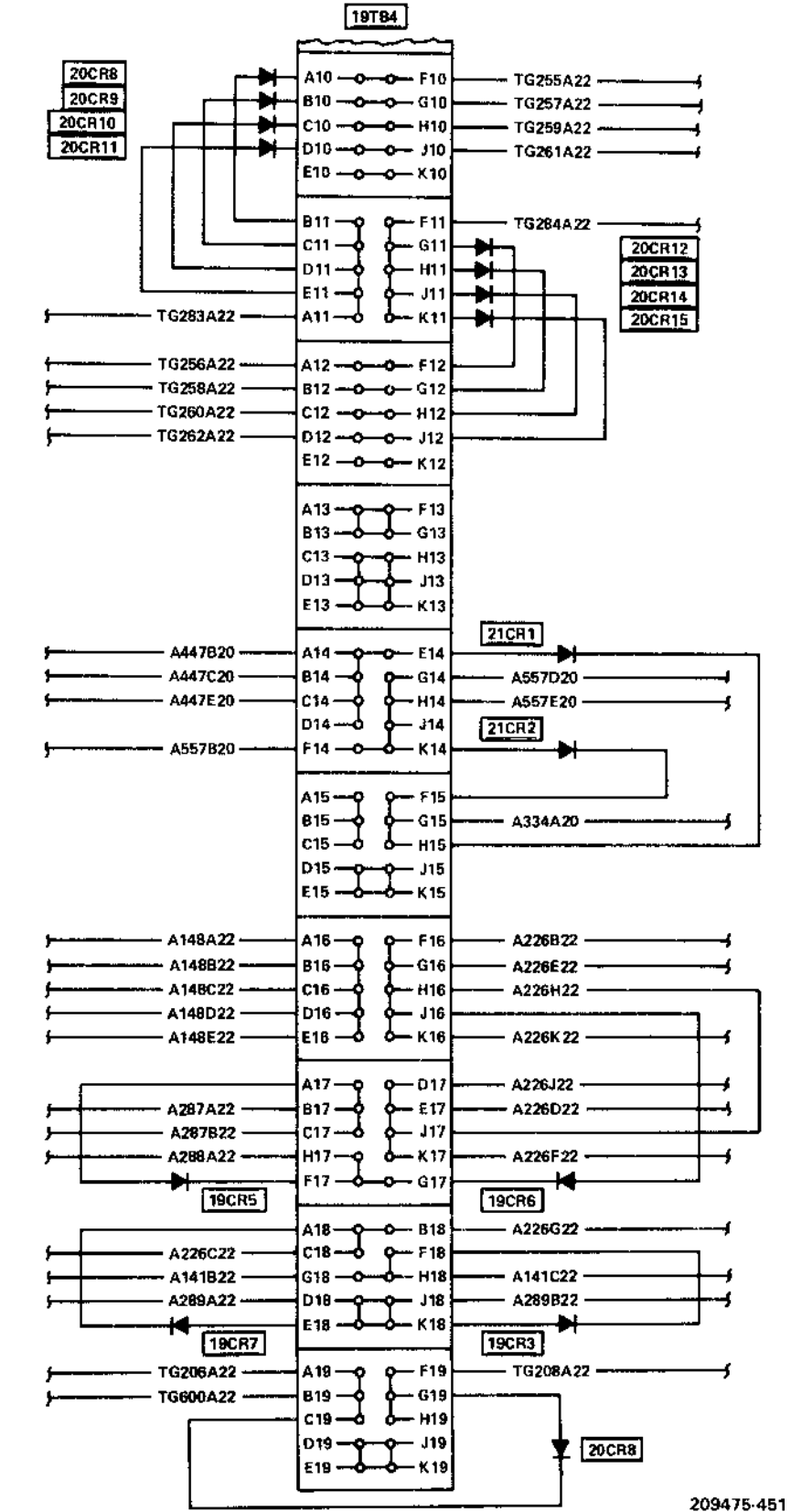
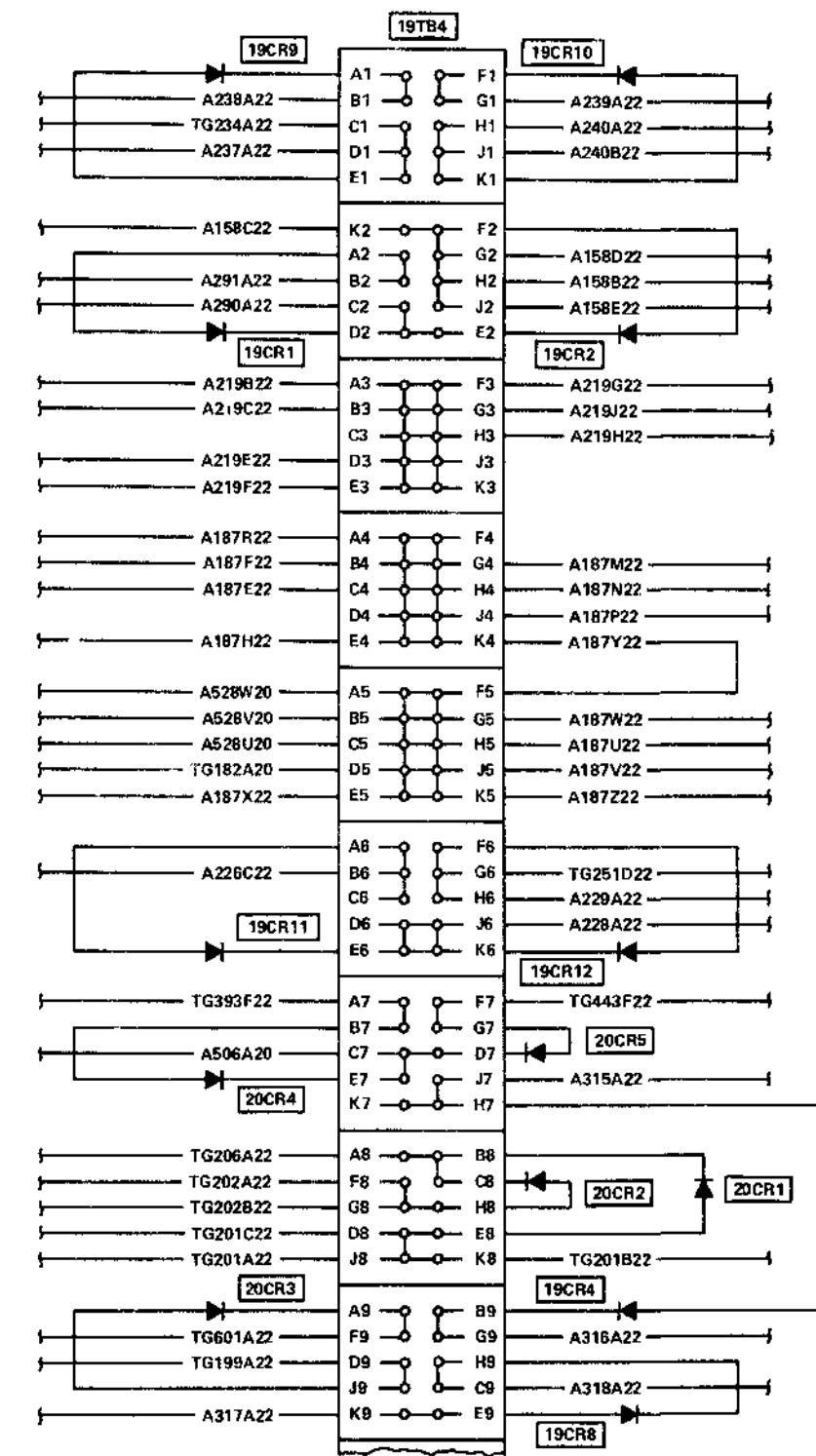

NOTE Where Sheet 1 is referenced see FO 80  
 Where Sheet 2 is referenced see FO 81  
 Where Sheet 3 is referenced see FO 82  
 Where Sheet 5 is referenced see FO 84  
 Where Sheet 6 is referenced see FO 85  
 Where Sheet 7 is referenced see FO 86  
 Where Sheet 8 is referenced see FO 87  
 Where Sheet 9 is referenced see FO 88  
 Where Sheet 10 is referenced see FO 89  
 Where Sheet 11 is referenced see FO 90

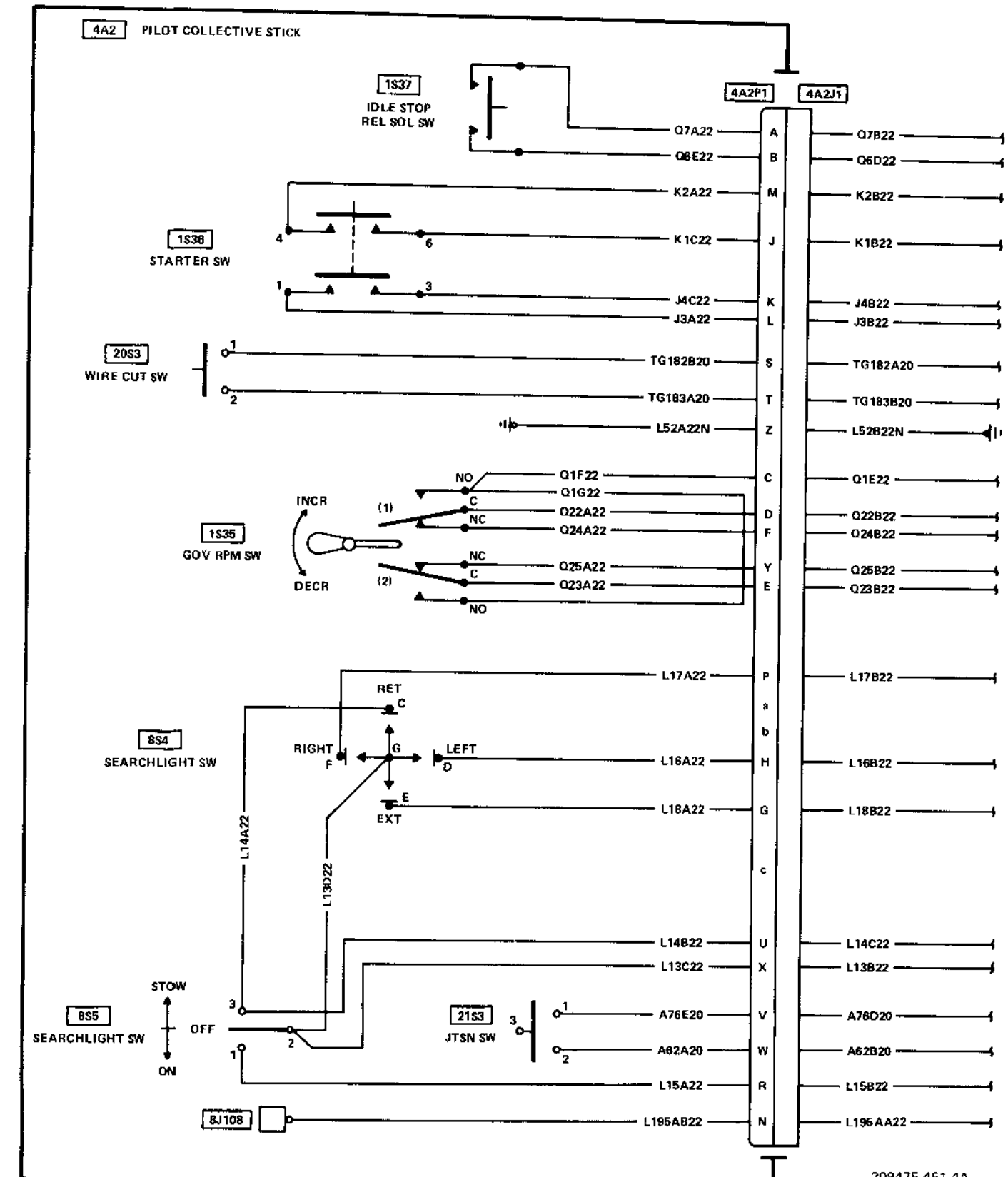
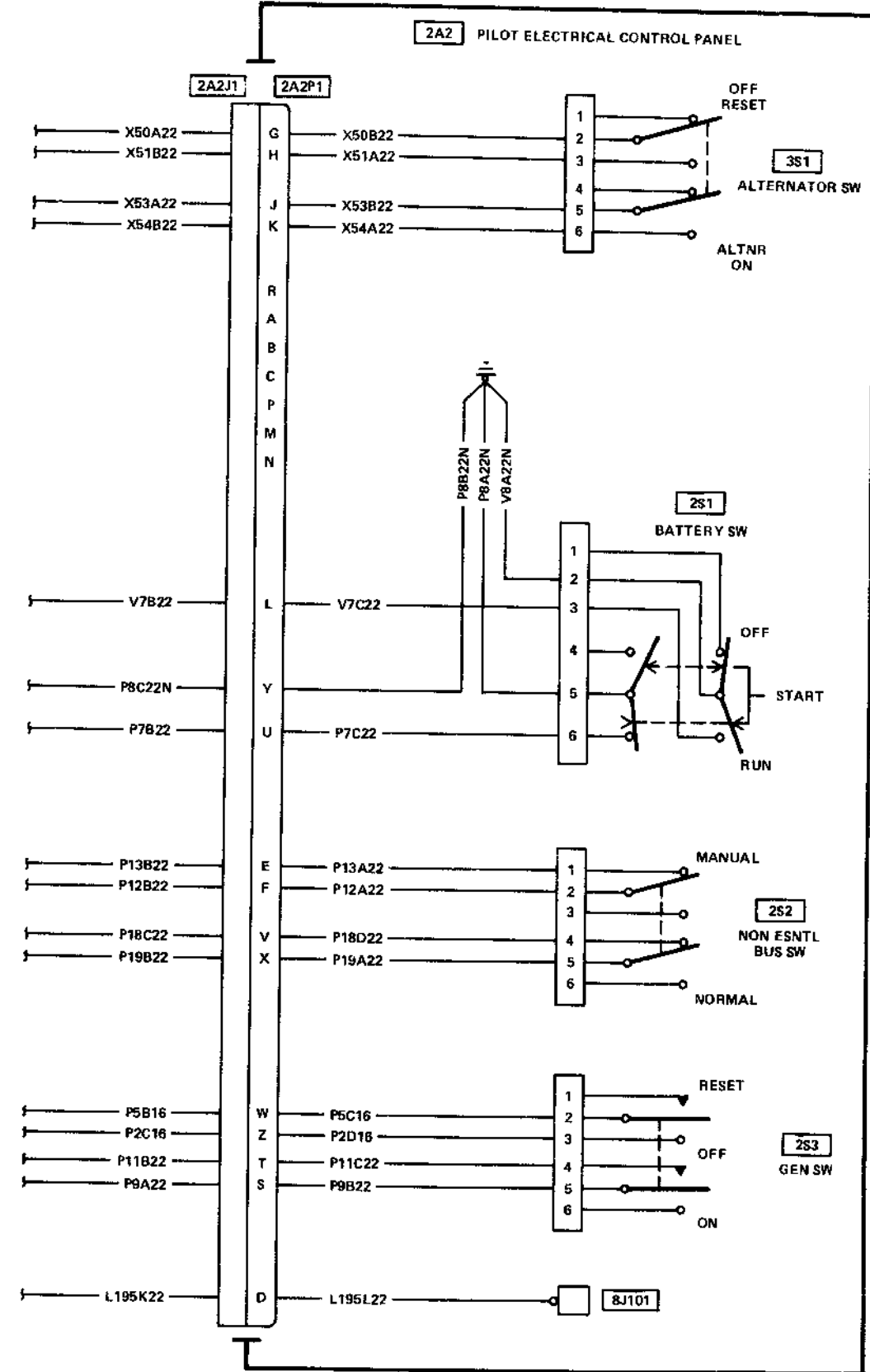
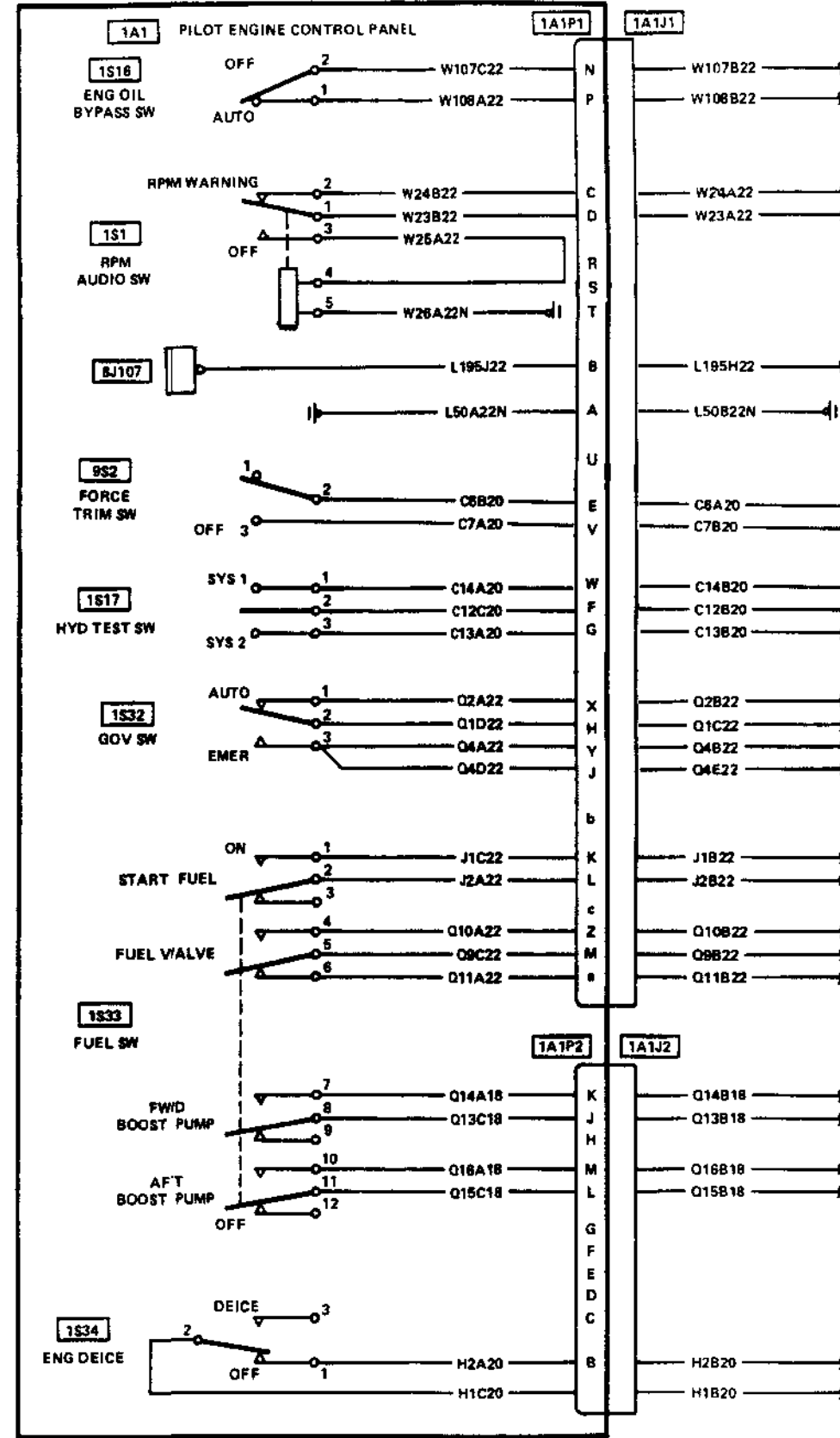

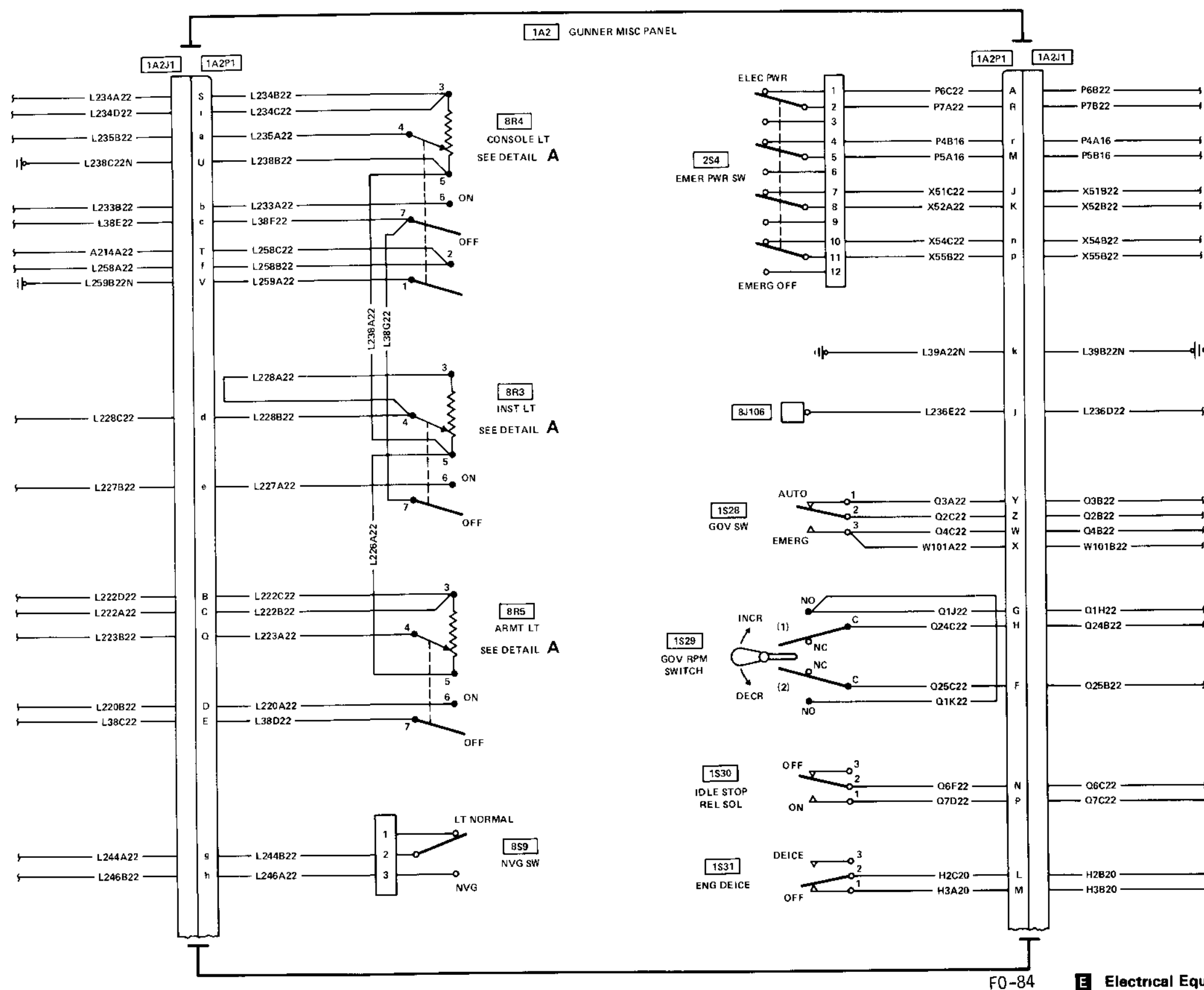

NOTE  
 Where Sheet 1 is referenced see F0-80  
 Where Sheet 2 is referenced see F0-81  
 Where Sheet 3 is referenced see F0-82.  
 Where Sheet 4 is referenced see F0-83  
 Where Sheet 6 is referenced see F0-85  
 Where Sheet 7 is referenced see F0-86  
 Where Sheet 8 is referenced see F0-87  
 Where Sheet 9 is referenced see F0-88  
 Where Sheet 10 is referenced see F0-89  
 Where Sheet 11 is referenced see F0-90

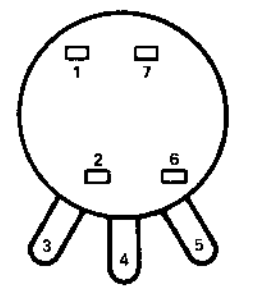

VIEW LOOKING AT REAR OF 110-046 ( ) RESISTOR  
 DETAIL A

NOTE Where Sheet 1 is referenced see FO 80  
 Where Sheet 2 is referenced see FO 81  
 Where Sheet 3 is referenced see FO 82  
 Where Sheet 4 is referenced see FO 83  
 Where Sheet 5 is referenced see FO 84  
 Where Sheet 7 is referenced see FO 86  
 Where Sheet 8 is referenced see FO 87  
 Where Sheet 9 is referenced see FO 88  
 Where Sheet 10 is referenced see FO 89  
 Where Sheet 11 is referenced see FO 90

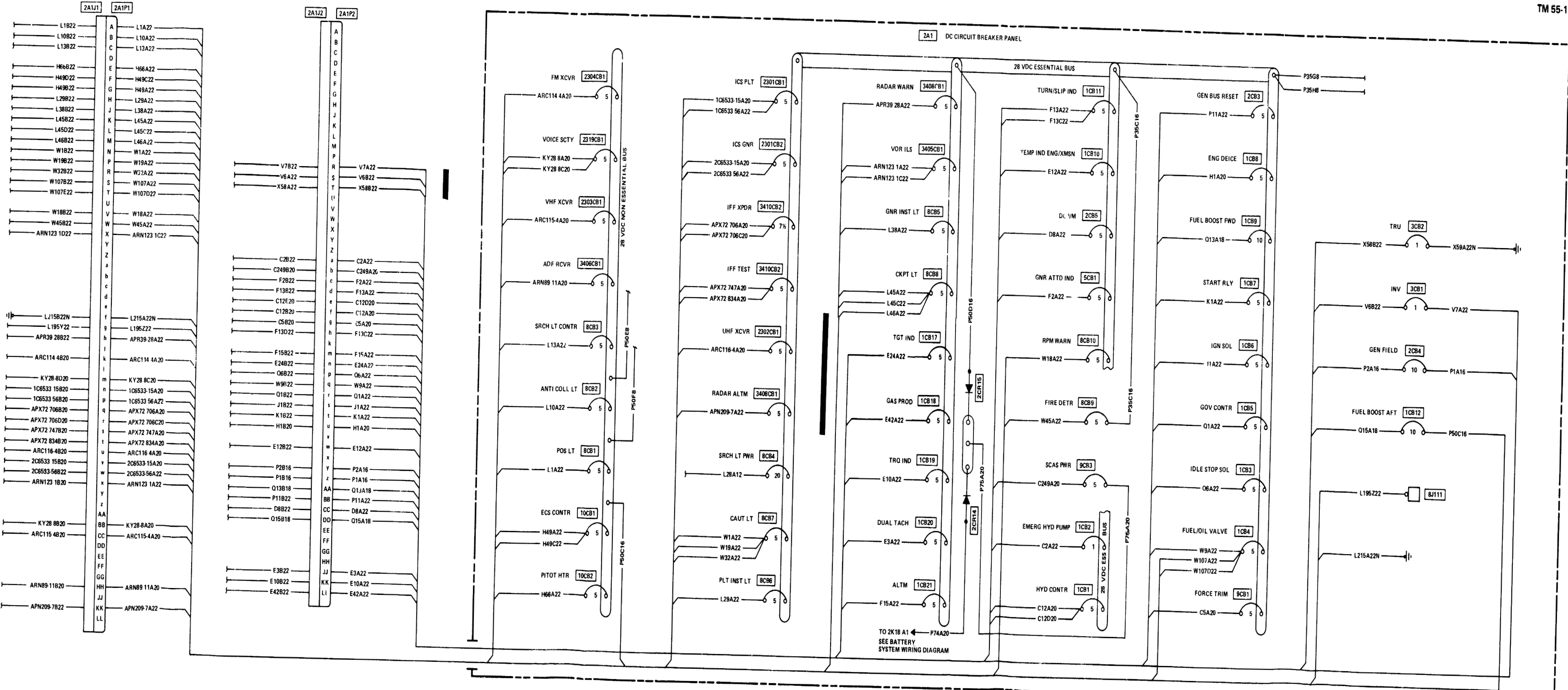



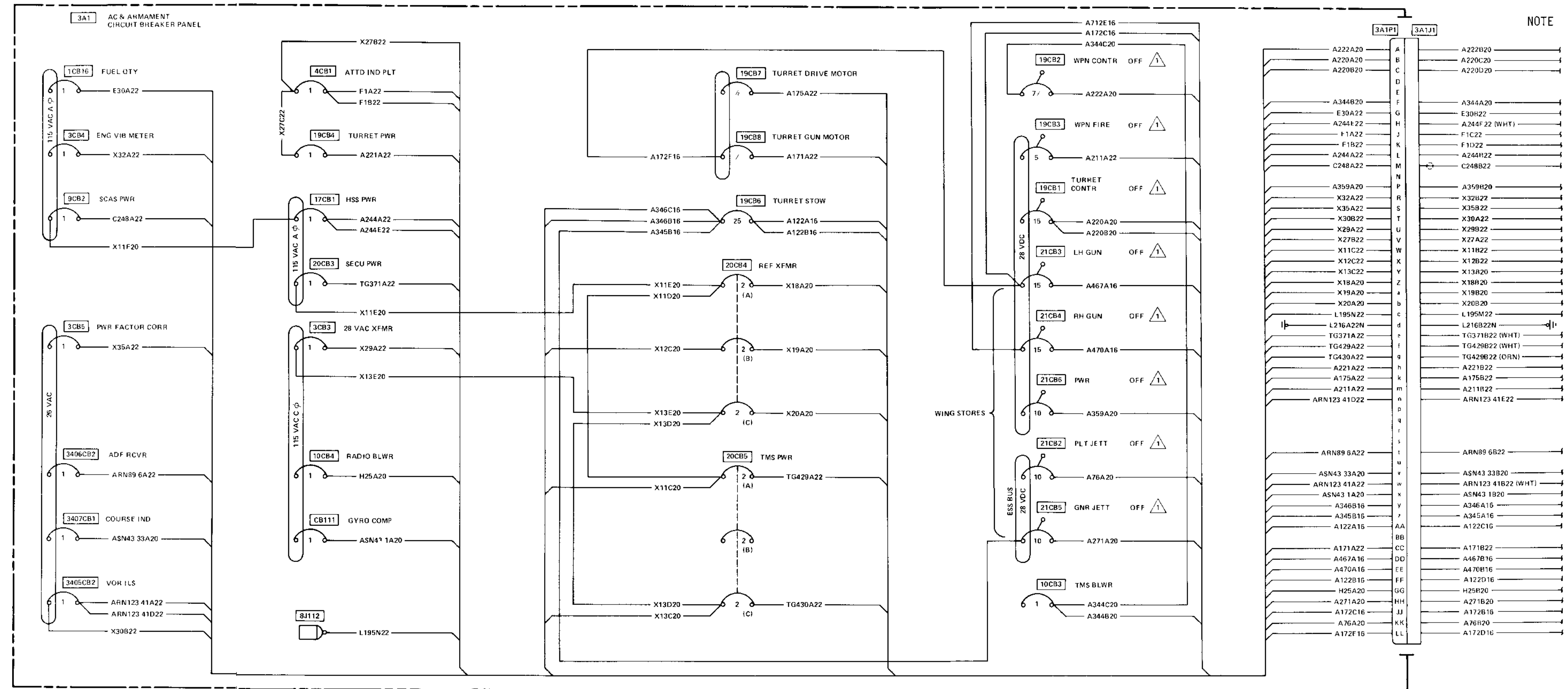

**NOTE**

Where Sheet 1 is referenced see F0-80  
 Where Sheet 2 is referenced see F0-81  
 Where Sheet 3 is referenced see F0-82  
 Where Sheet 4 is referenced see F0-83  
 Where Sheet 5 is referenced see F0-84  
 Where Sheet 6 is referenced see F0-85  
 Where Sheet 8 is referenced see F0-87  
 Where Sheet 9 is referenced see F0-88  
 Where Sheet 10 is referenced see F0-89  
 Where Sheet 11 is referenced see F0-90

**NOTE**

CIRCUIT BREAKER IS SWITCH TYPE WITH OFF (OPEN) IN DOWN POSITION

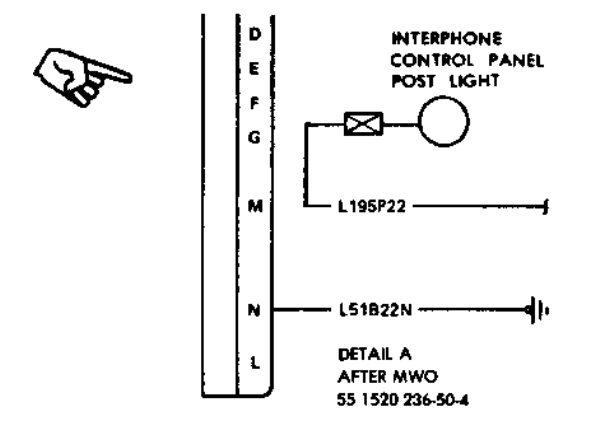

**NOTE** Where Sheet 1 is referenced see FO-80  
 Where Sheet 2 is referenced see FO-81  
 Where Sheet 3 is referenced see FO-82  
 Where Sheet 4 is referenced see FO-83  
 Where Sheet 5 is referenced see FO-84  
 Where Sheet 6 is referenced see FO-85  
 Where Sheet 7 is referenced see FO-86  
 Where Sheet 9 is referenced see FO-88  
 Where Sheet 10 is referenced see FO-89  
 Where Sheet 11 is referenced see FO-90

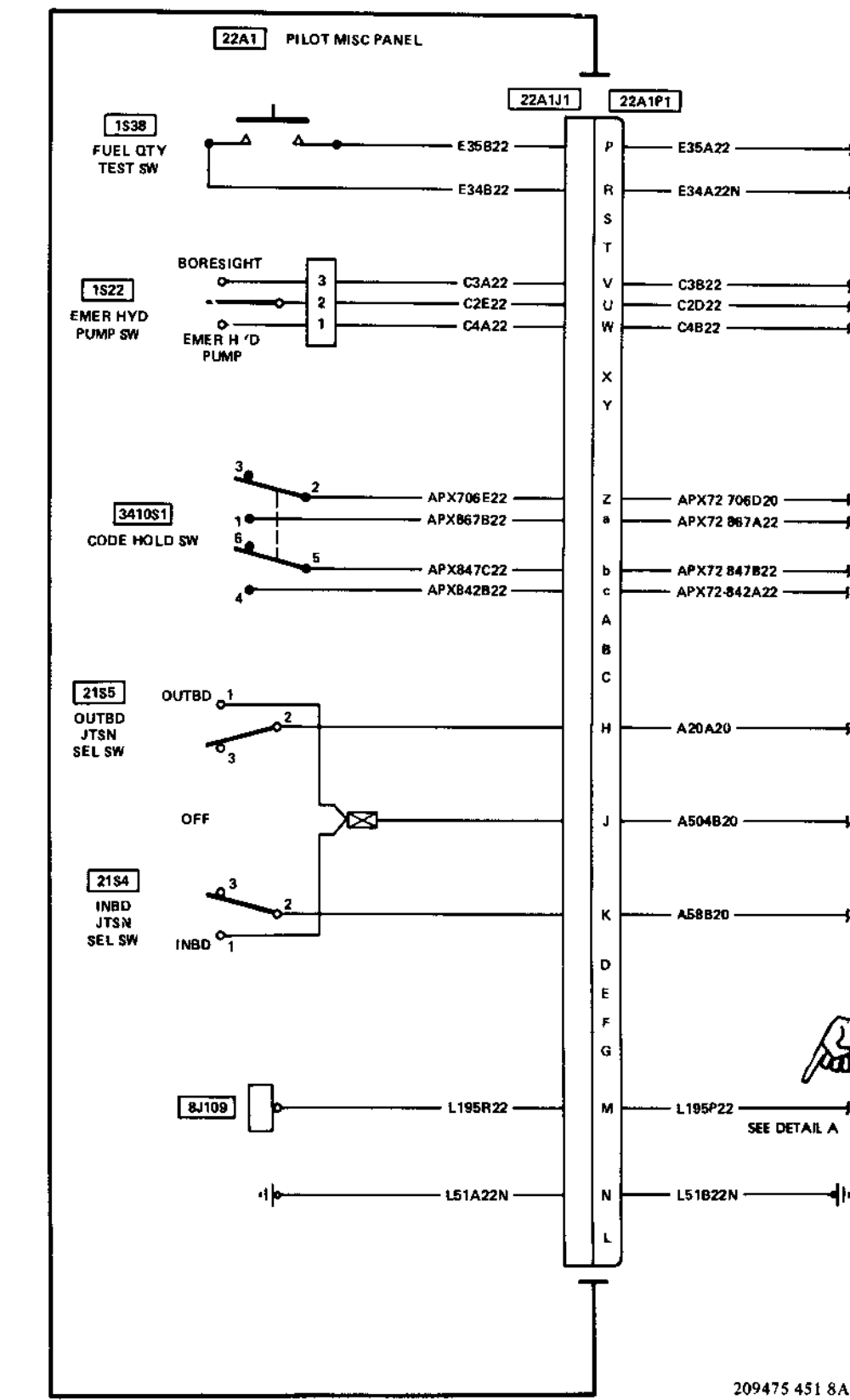
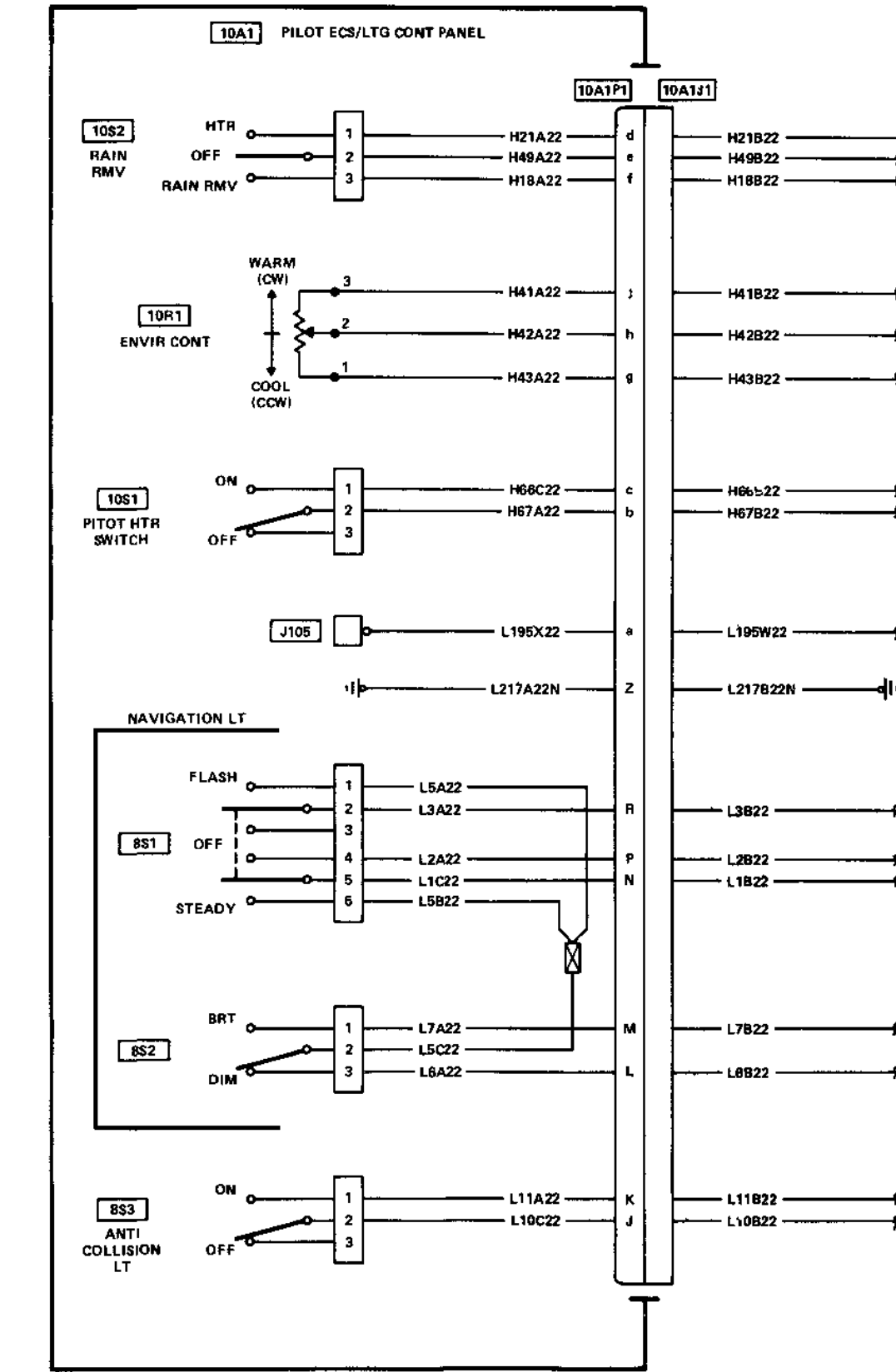
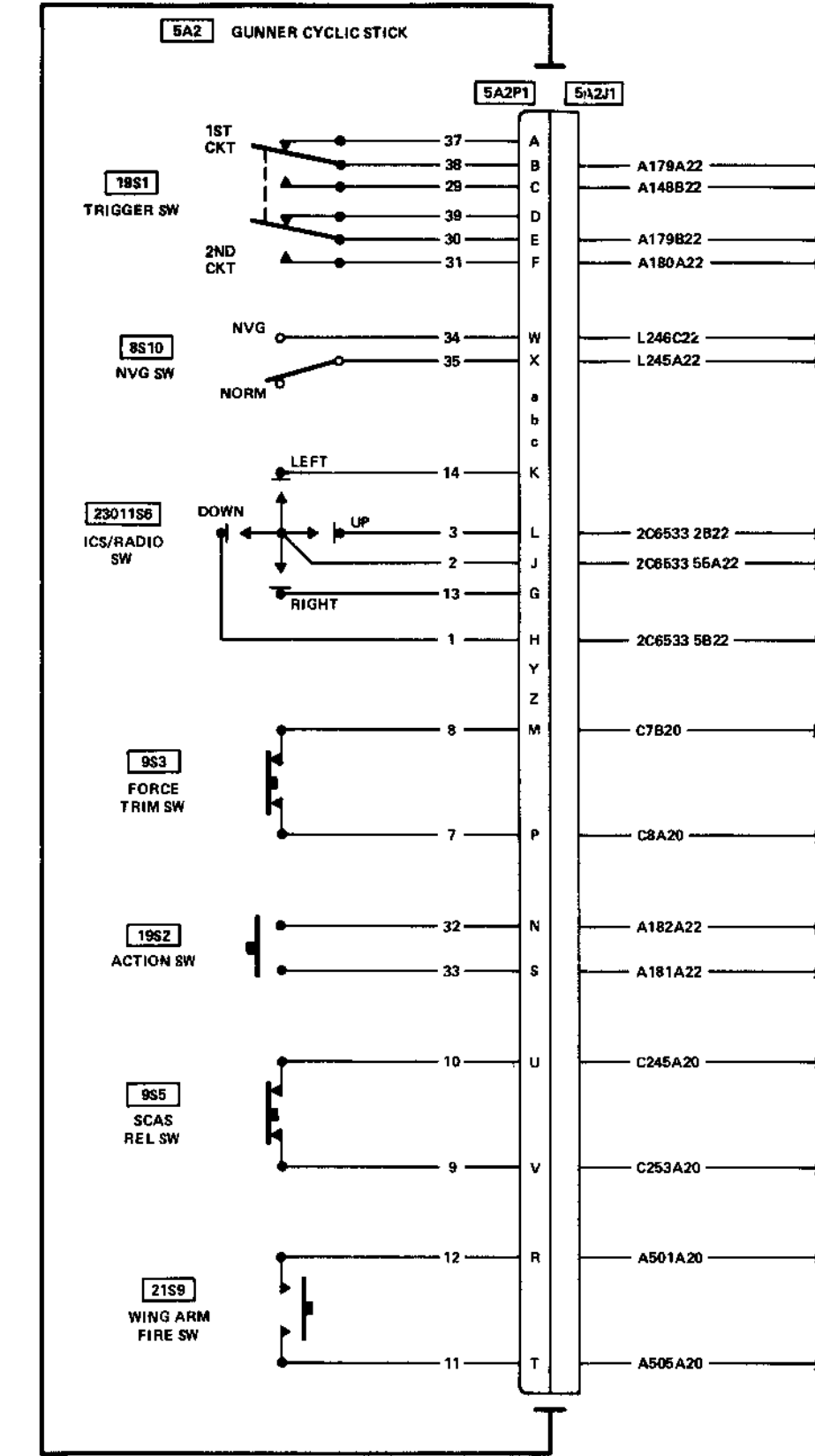
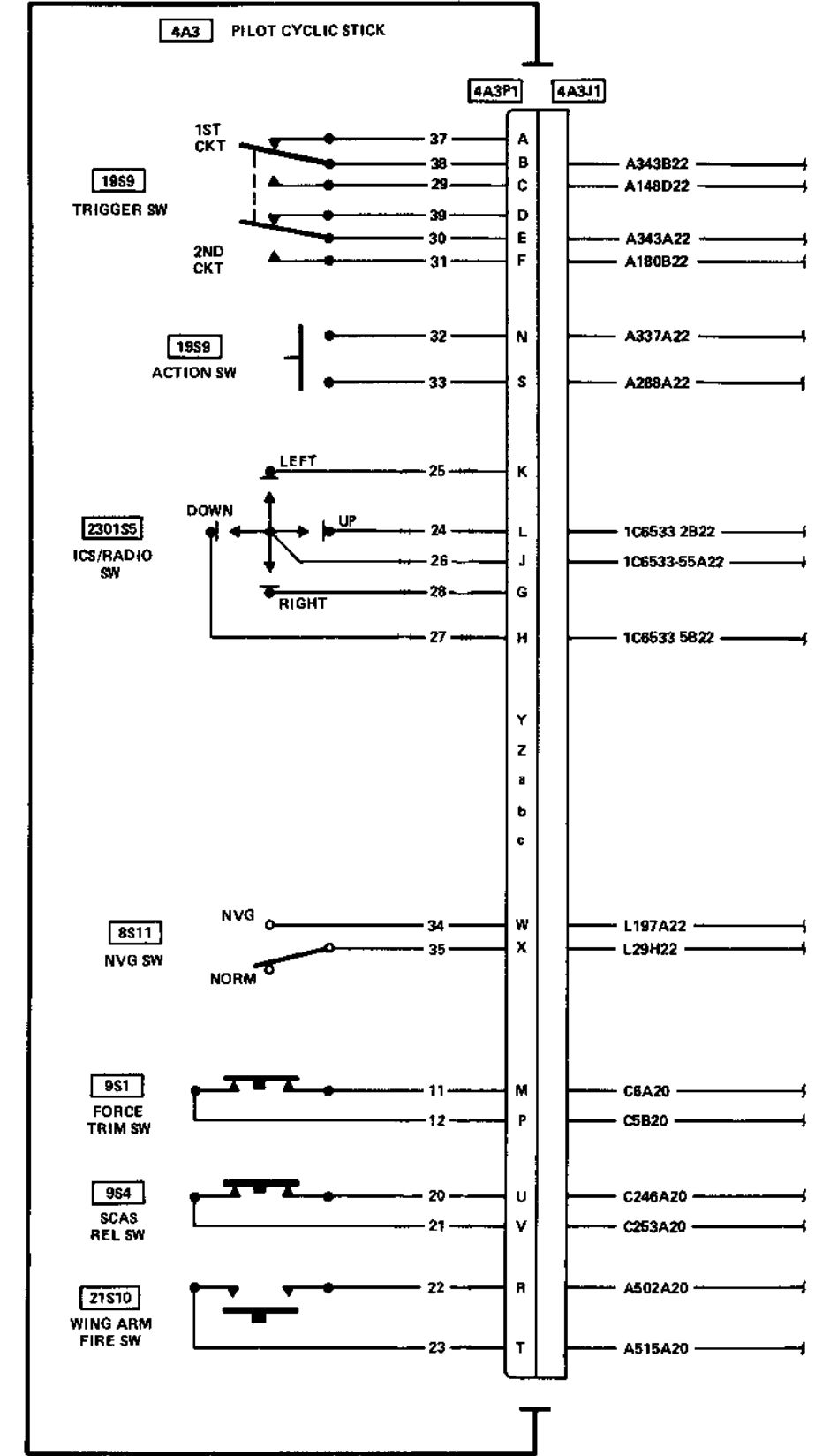

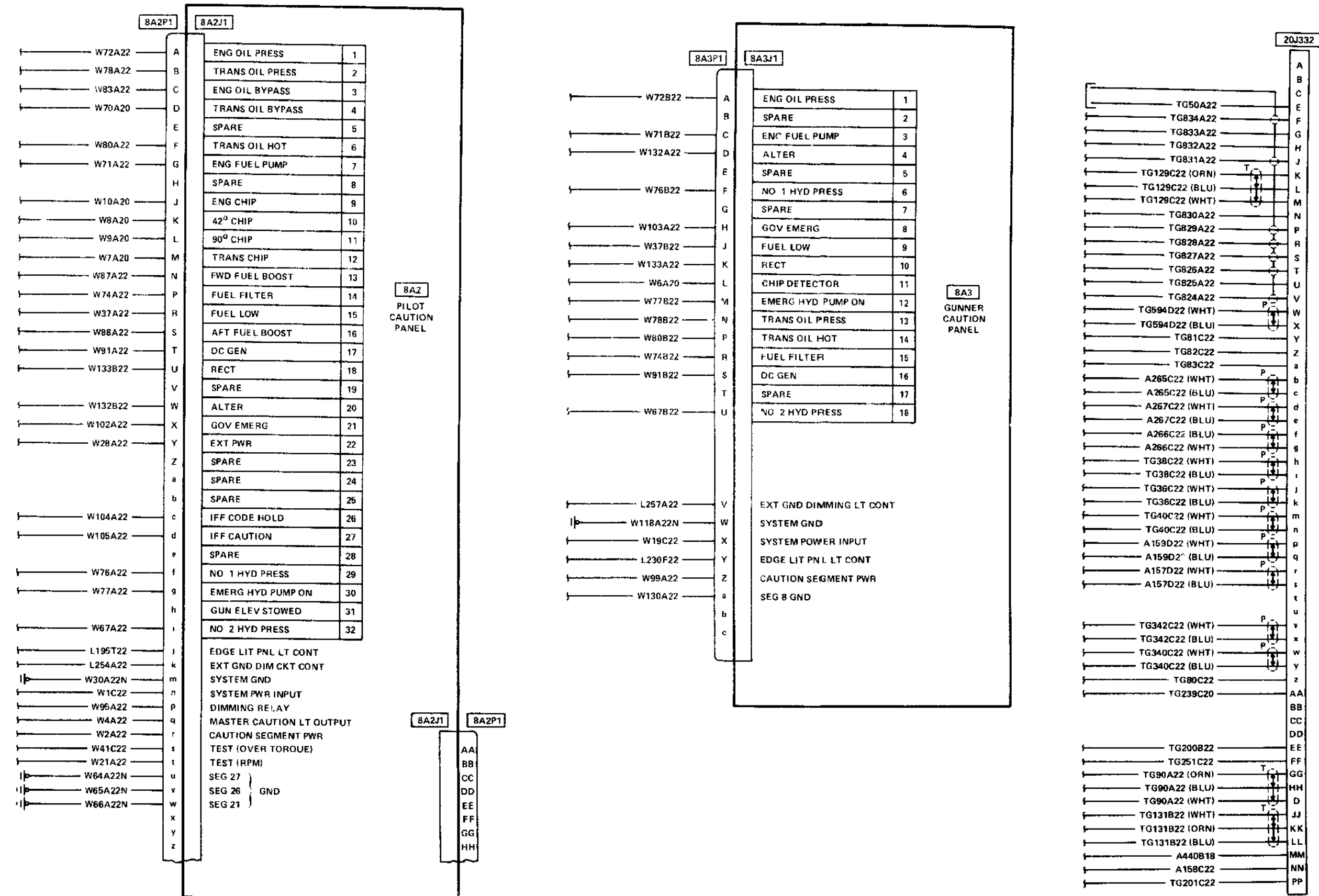

NOTE Where Sheet 1 is referenced see FO 80  
 Where Sheet 2 is referenced see FO 81  
 Where Sheet 3 is referenced see FO 82  
 Where Sheet 4 is referenced see FO 83  
 Where Sheet 5 is referenced see FO 84  
 Where Sheet 6 is referenced see FO 85  
 Where Sheet 7 is referenced see FO 86  
 Where Sheet 8 is referenced see FO 87  
 Where Sheet 10 is referenced see FO 89  
 Where Sheet 11 is referenced see FO 90

NOTE Where Sheet 1 is referenced see FO-80  
 Where Sheet 2 is referenced see FO-81  
 Where Sheet 3 is referenced see FO-82  
 Where Sheet 4 is referenced see FO-83  
 Where Sheet 5 is referenced see FO-84  
 Where Sheet 6 is referenced see FO-85  
 Where Sheet 7 is referenced see FO-86  
 Where Sheet 8 is referenced see FO-87  
 Where Sheet 9 is referenced see FO-88  
 Where Sheet 11 is referenced see FO-90

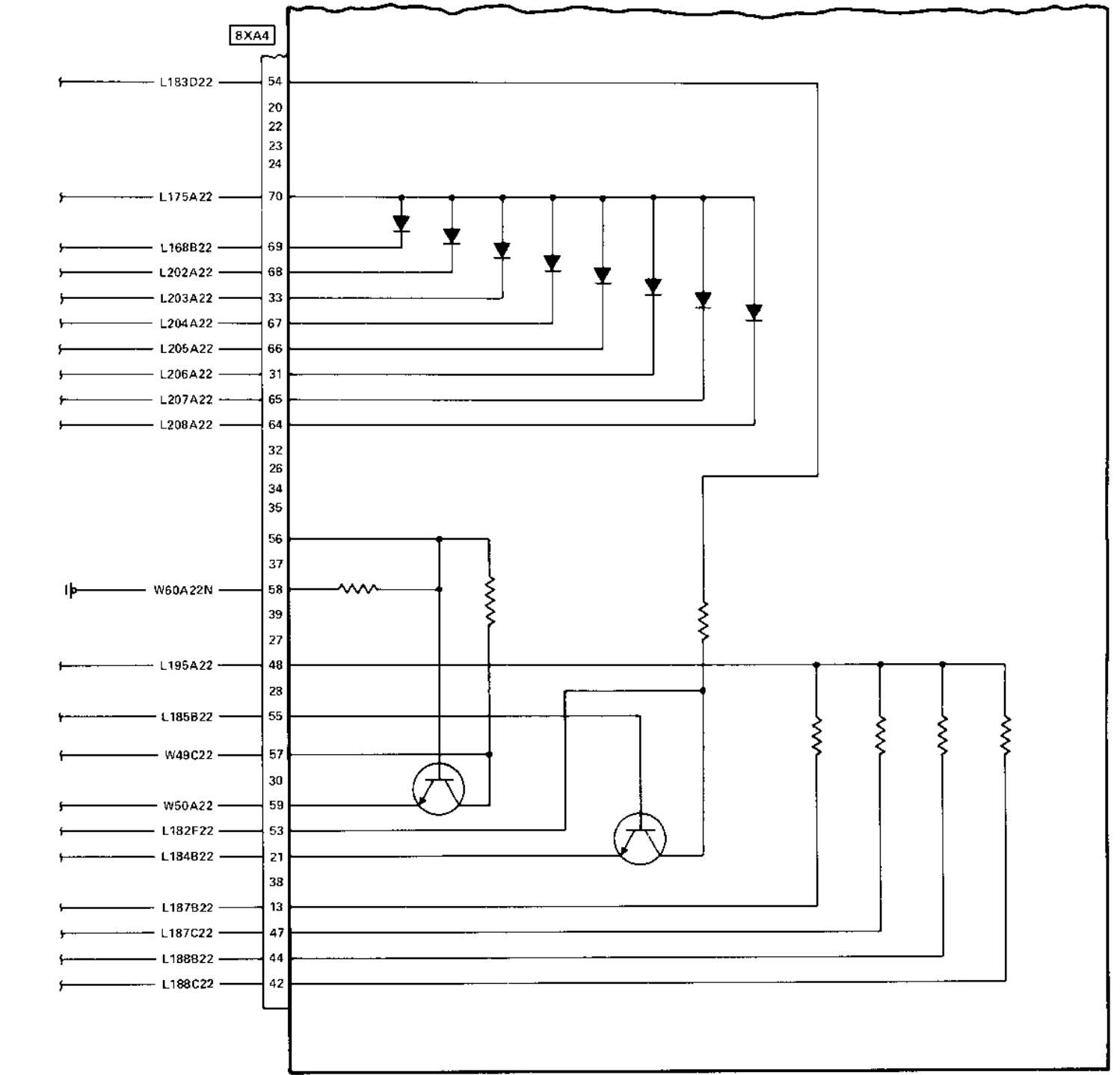
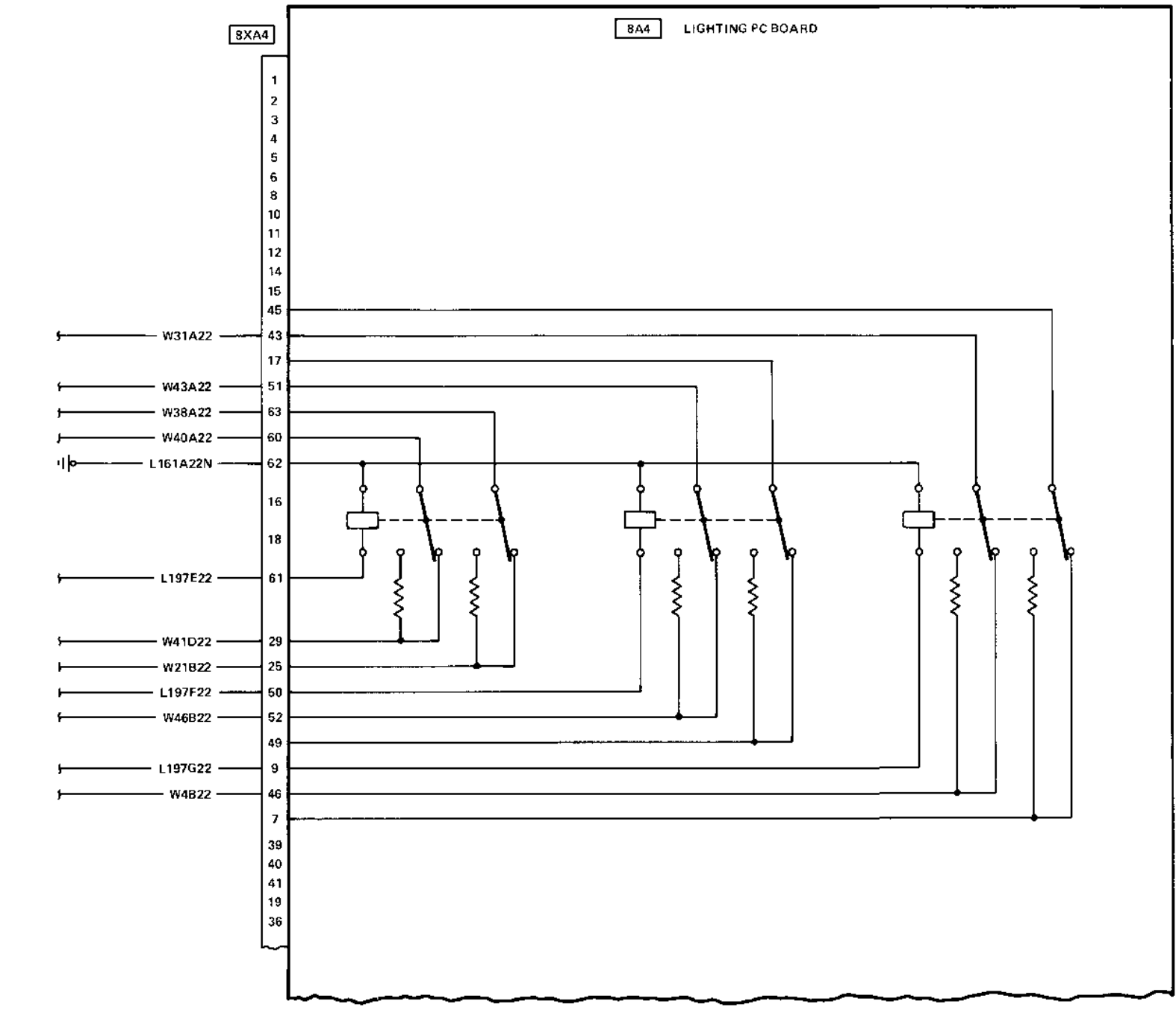

NOTE Where Sheet 1 is referenced see F0-80  
 Where Sheet 2 is referenced see F0-81  
 Where Sheet 3 is referenced see F0-82  
 Where Sheet 4 is referenced see F0-83  
 Where Sheet 5 is referenced see F0-84  
 Where Sheet 6 is referenced see F0-85  
 Where Sheet 7 is referenced see F0-86  
 Where Sheet 8 is referenced see F0-87  
 Where Sheet 9 is referenced see F0-88  
 Where Sheet 10 is referenced see F0-89

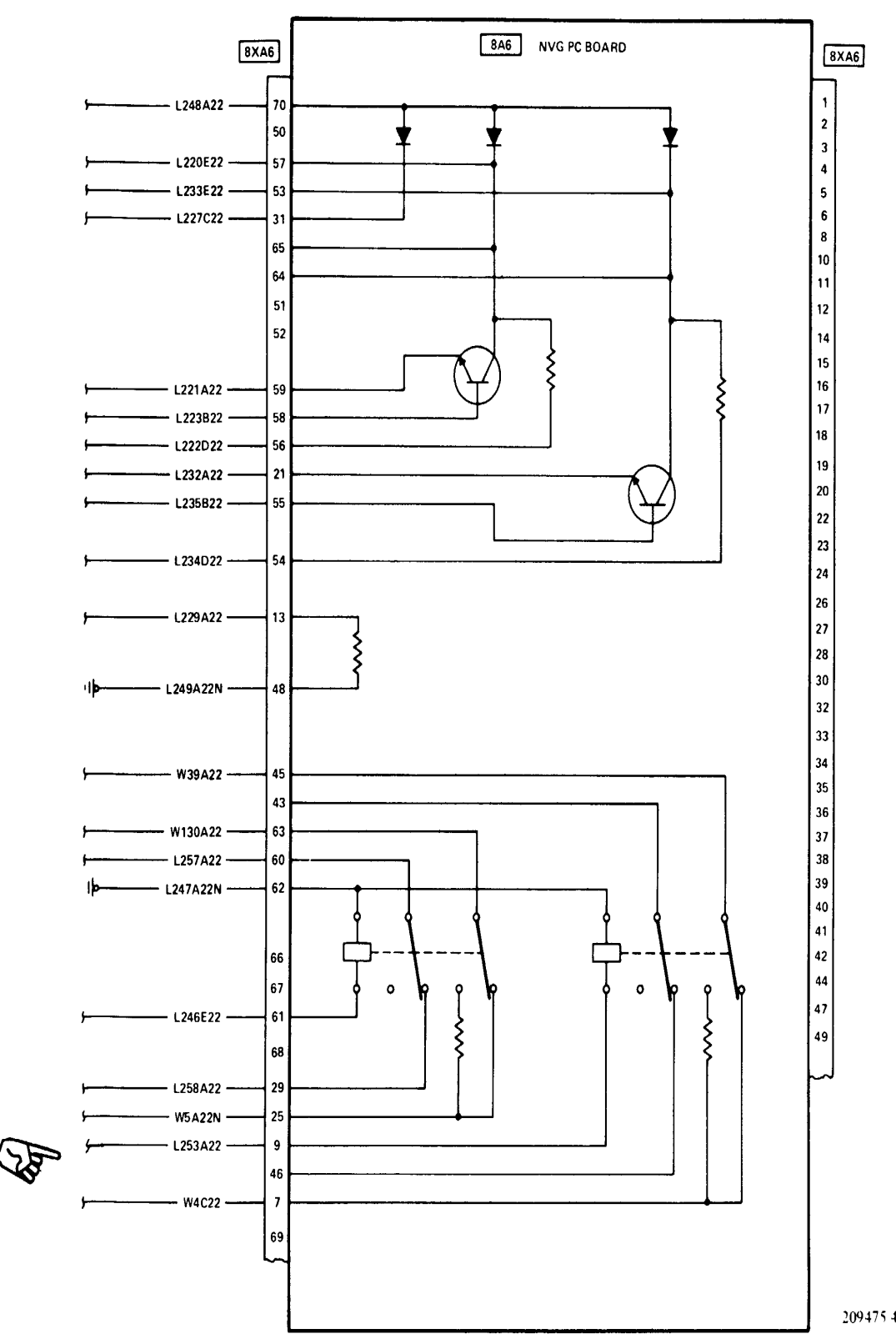
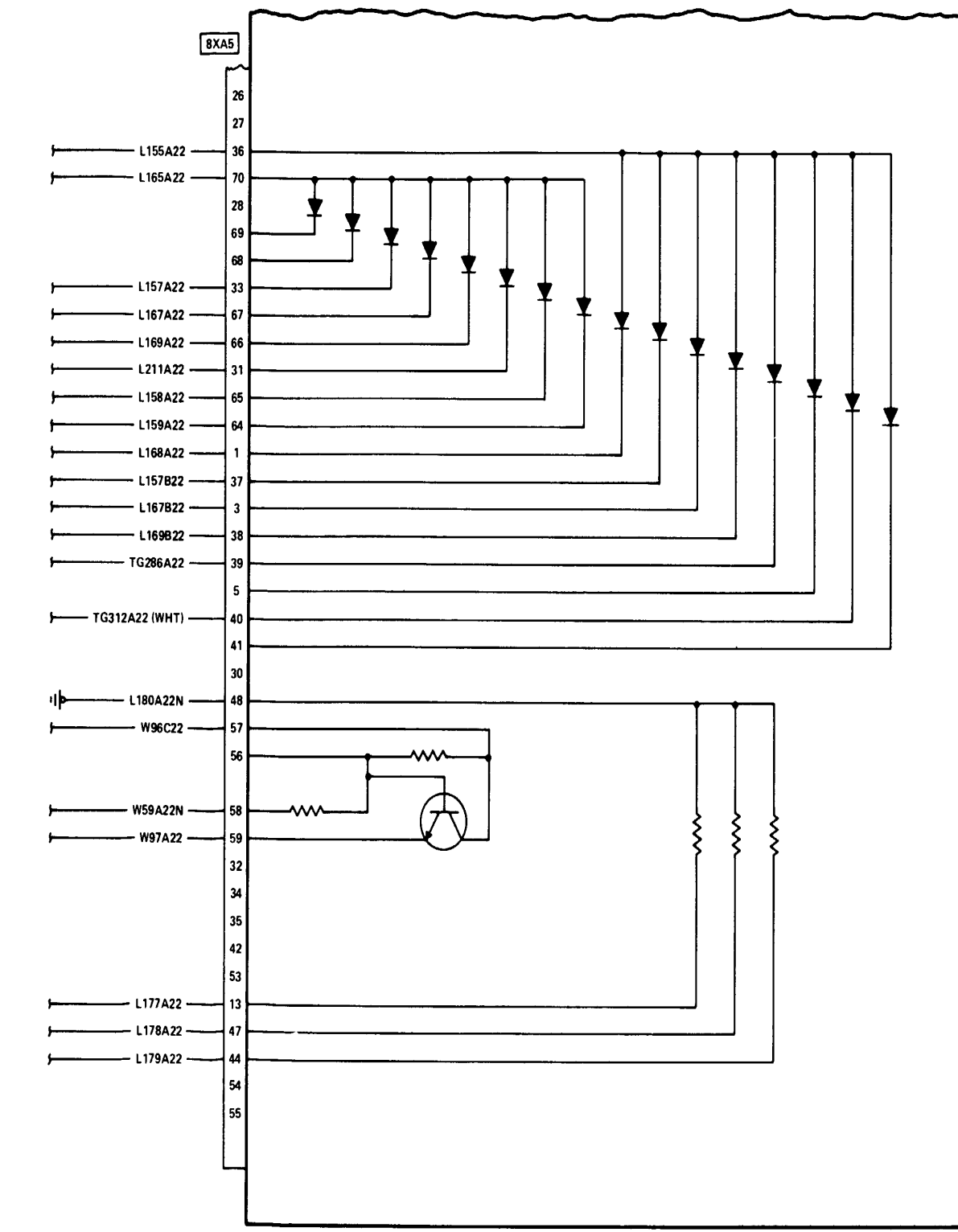
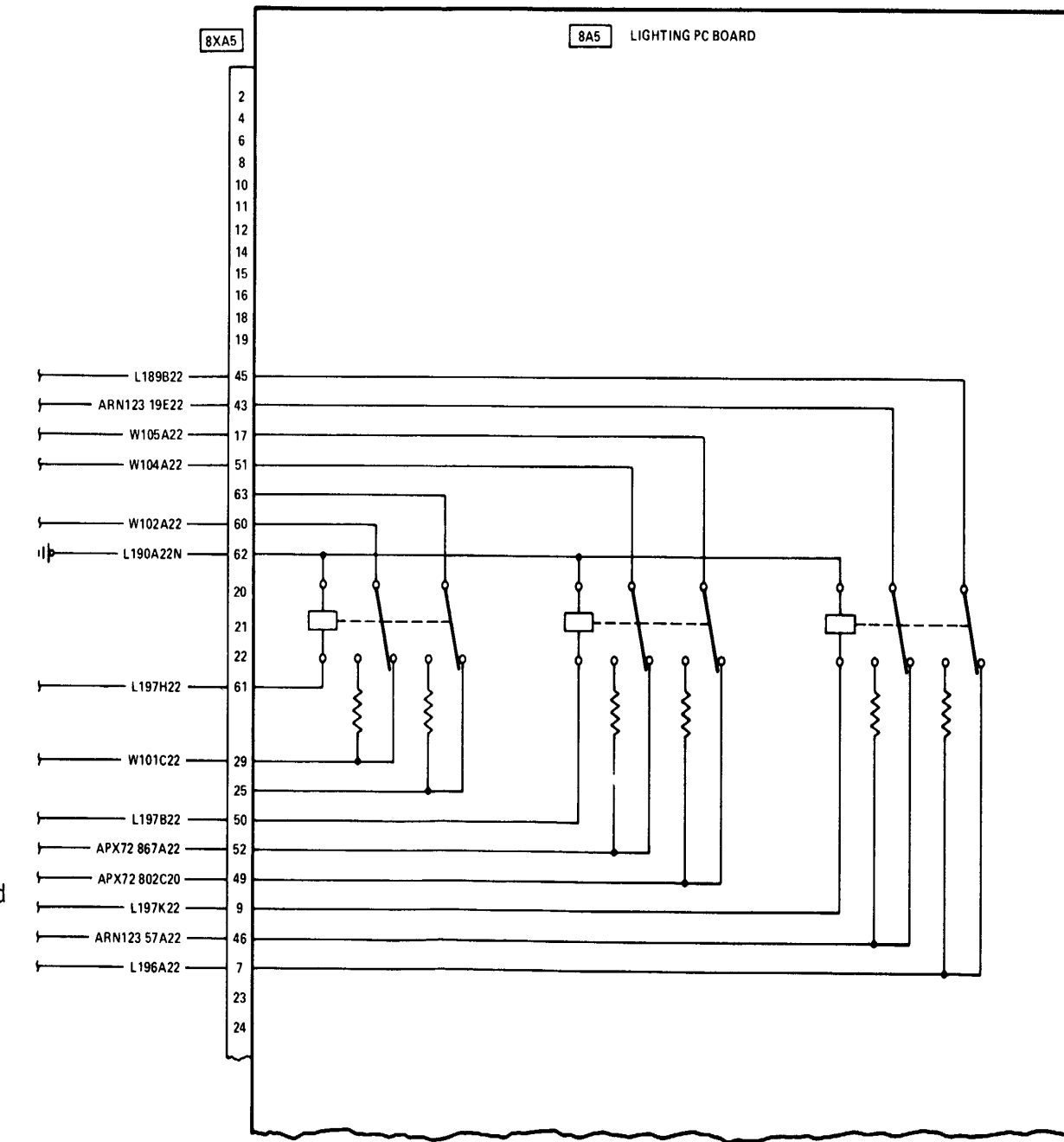

F0-90 Electrical Equipment Component Replacement

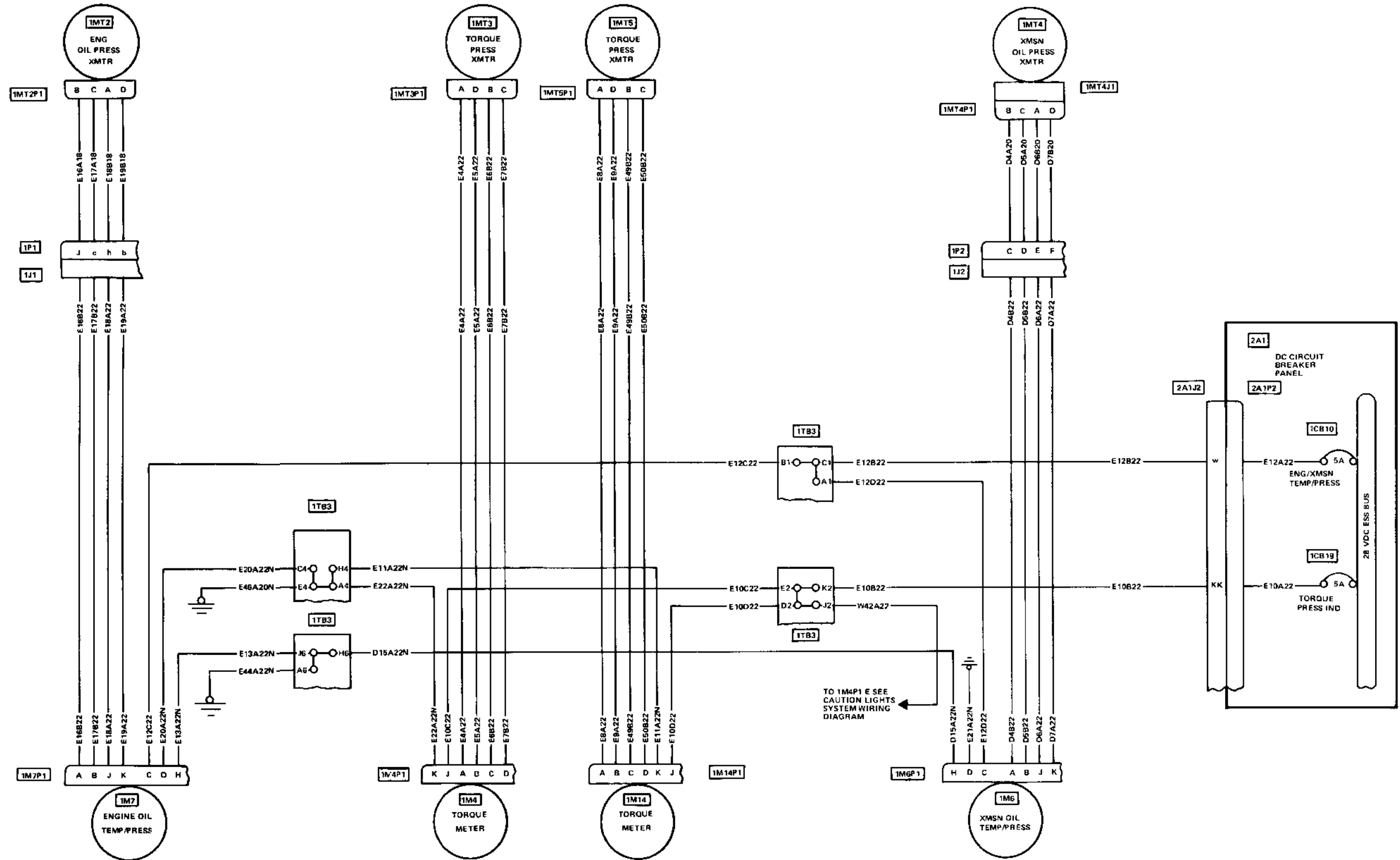

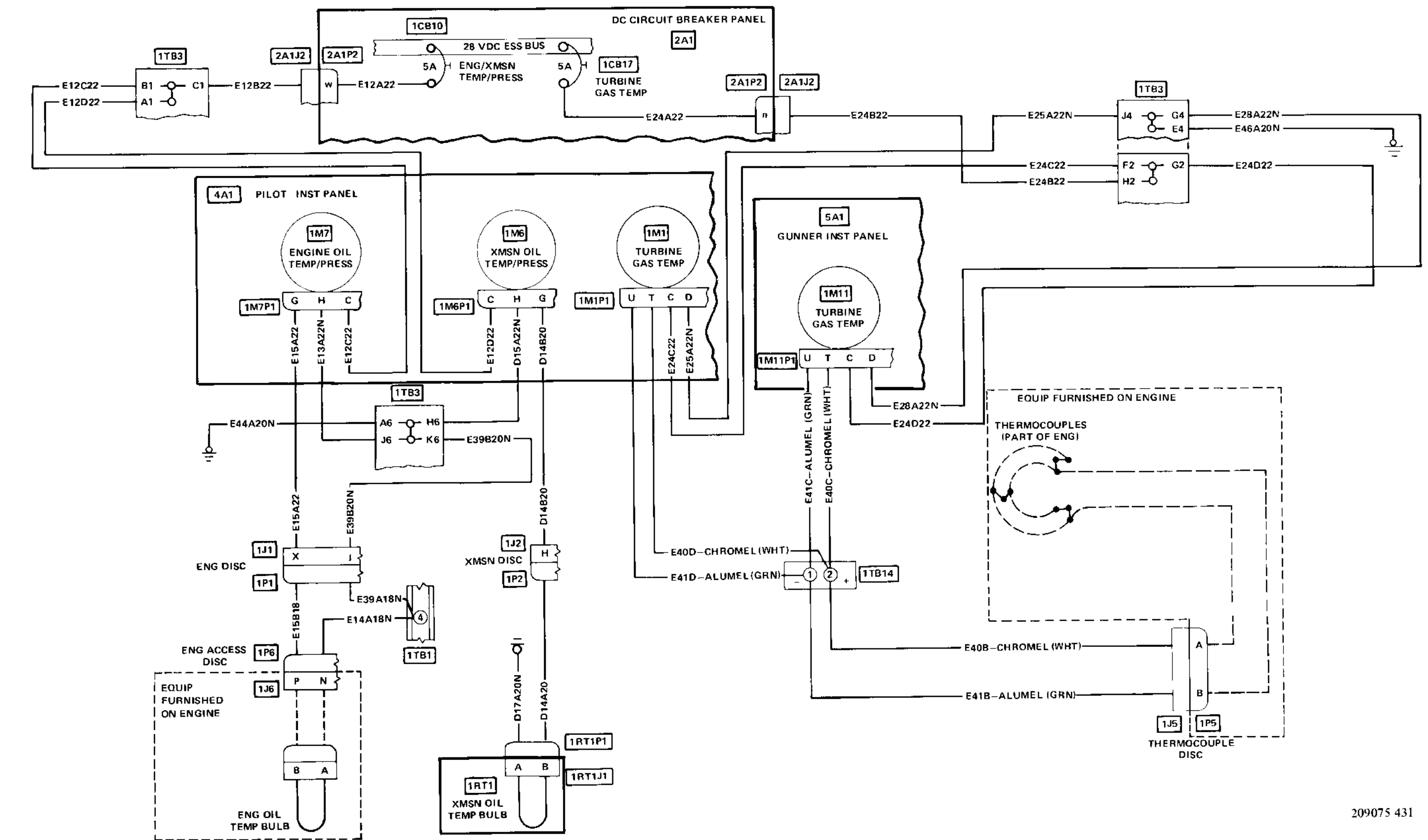

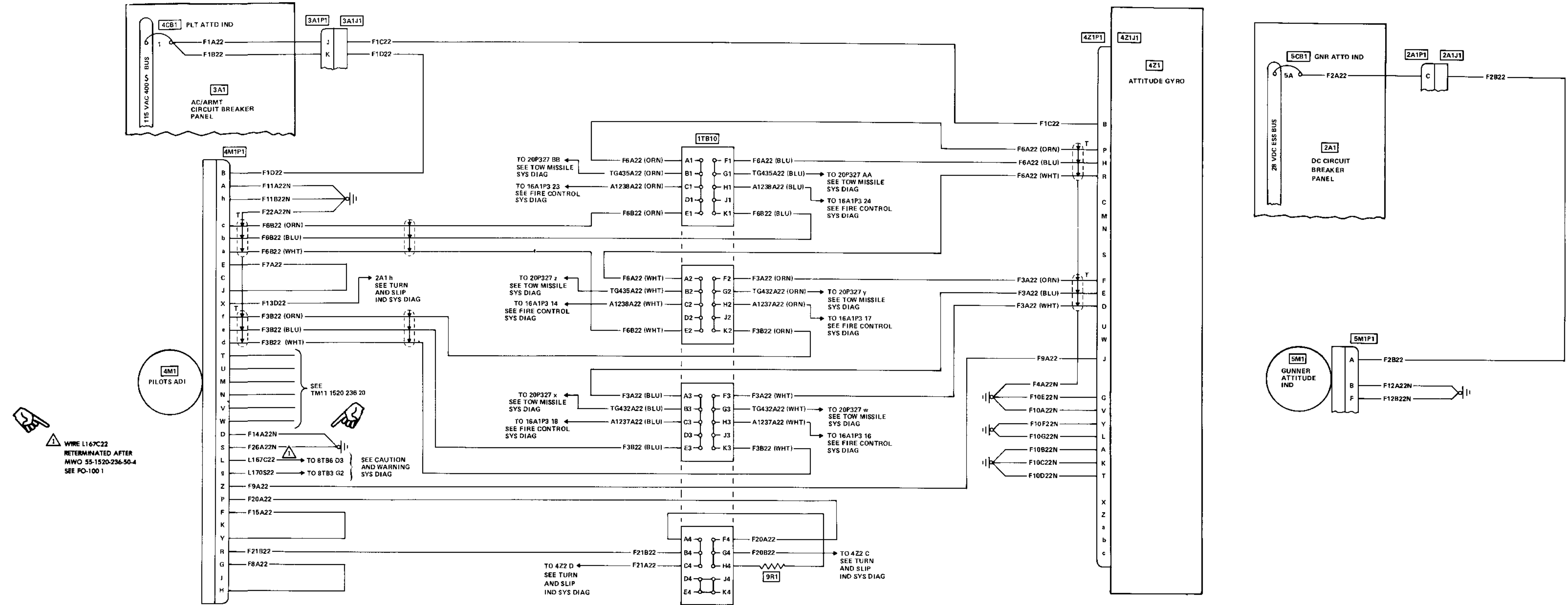



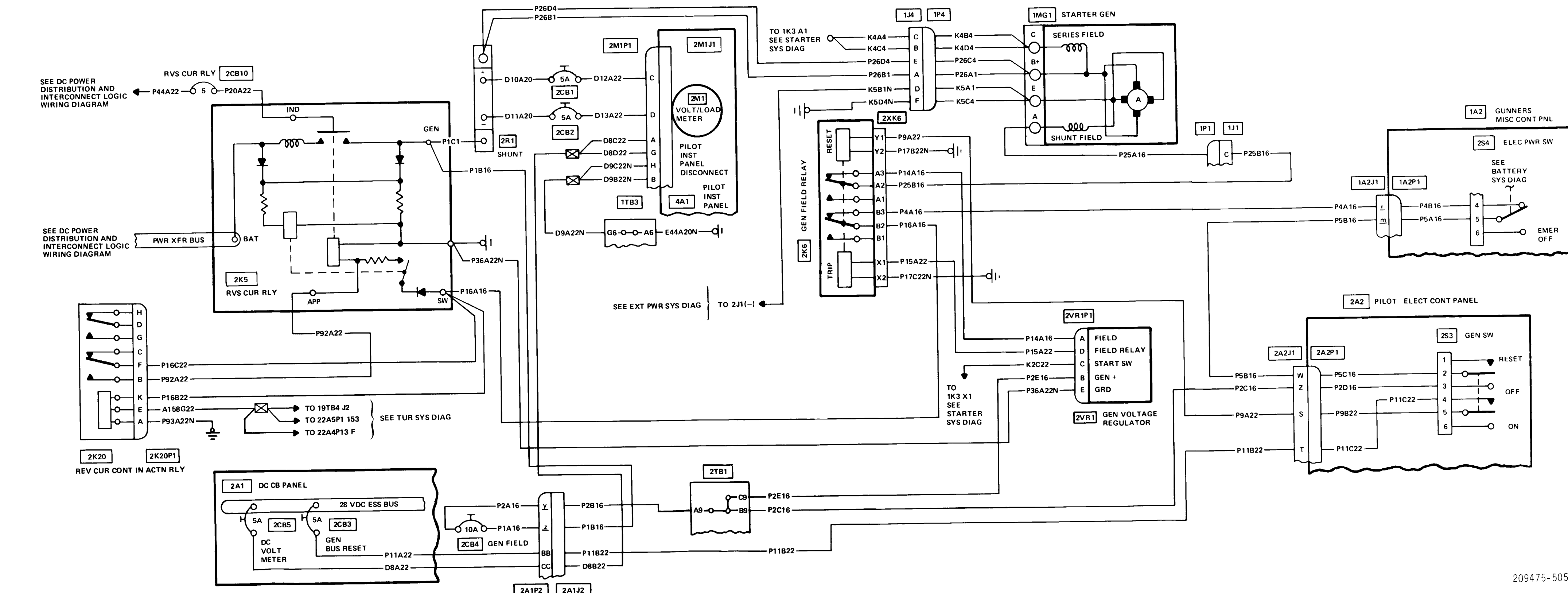

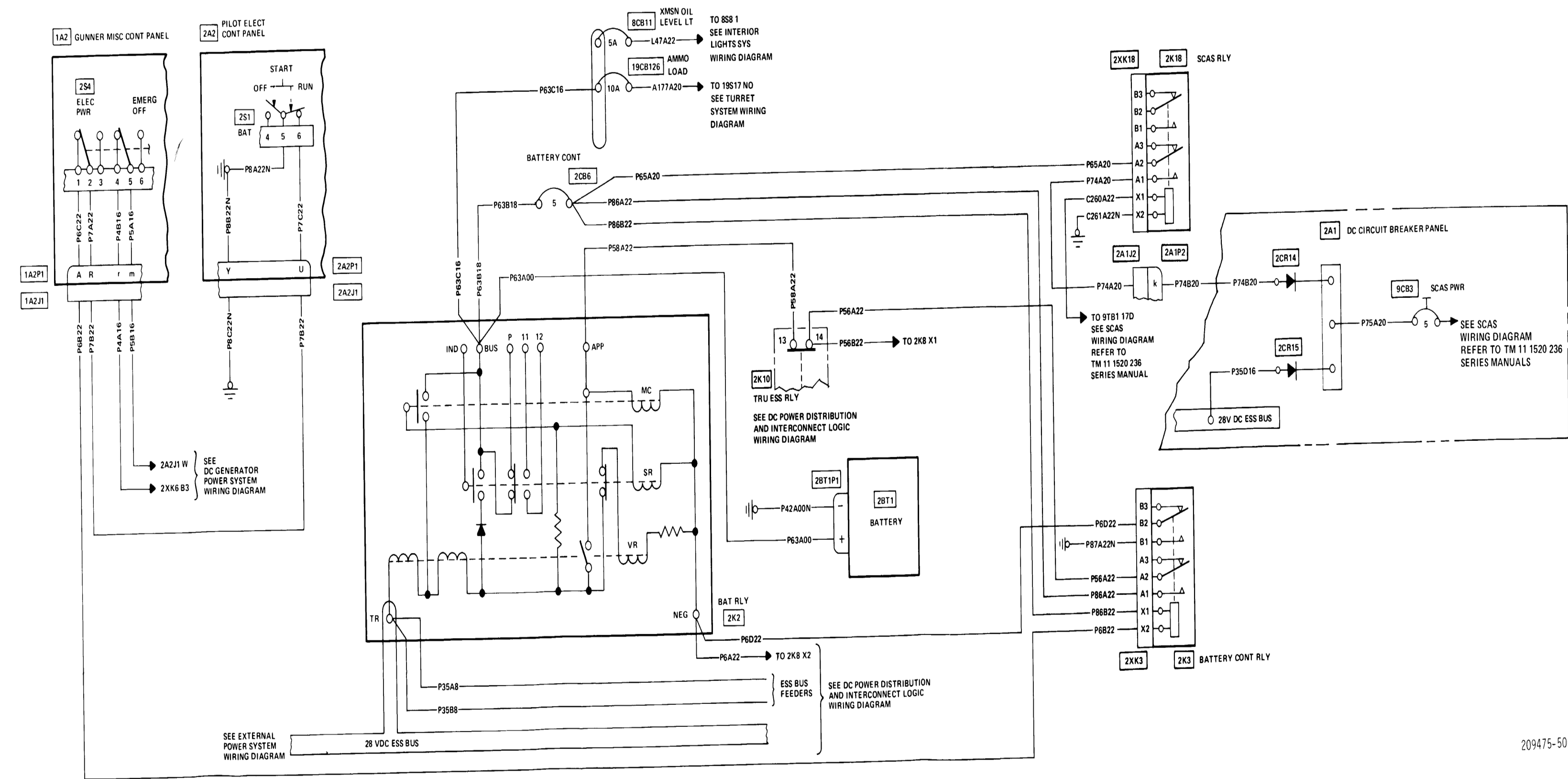

209475-506

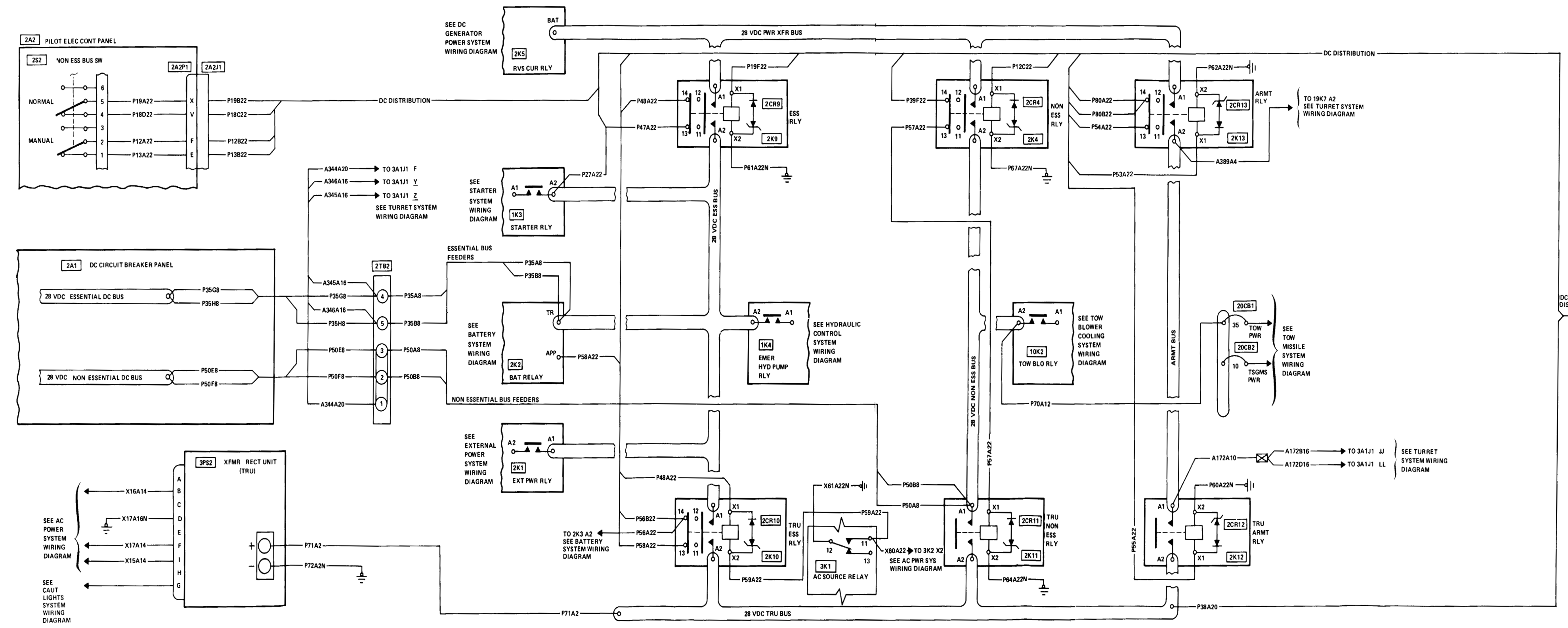

NOTE Where Sheet 2 is referenced see FO-97

- P12B22
- P12C22
- P13B22
- P18C22
- P19B22
- P19F22
- P27A22
- P38A20
- P39F22
- P47A22
- P53A22
- P54A22
- P55A22
- P56B22
- P80A22
- P80B22

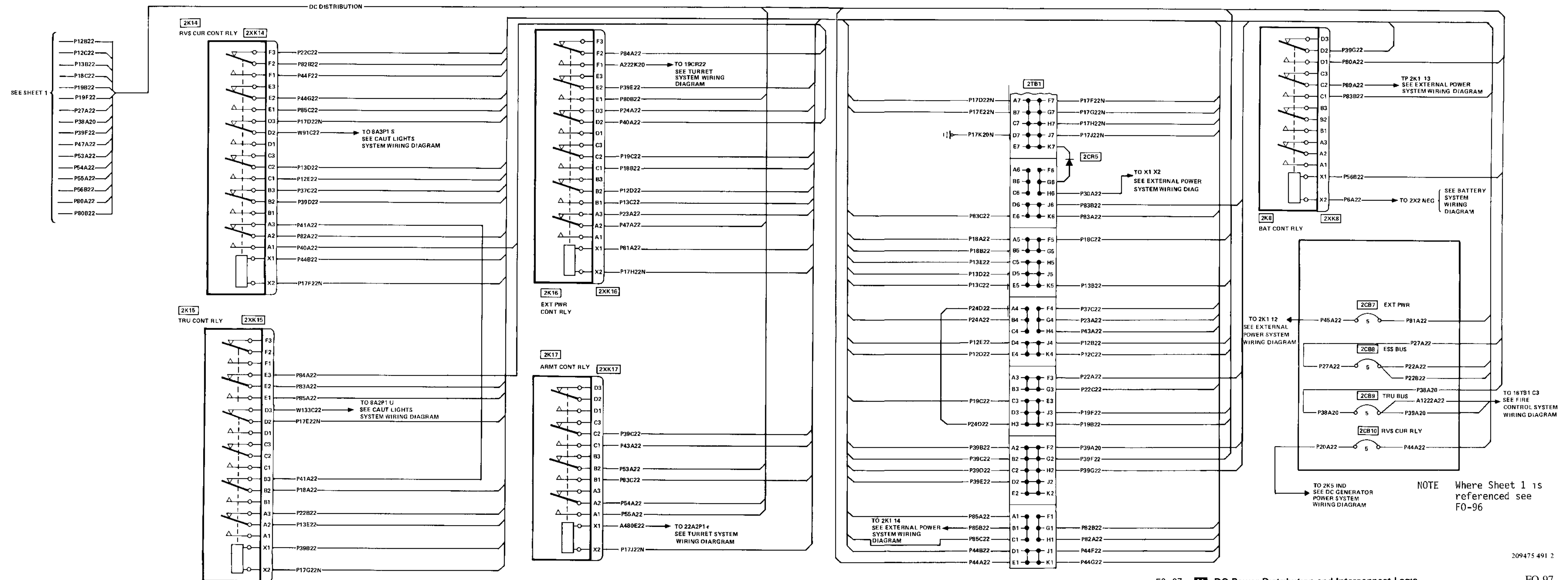

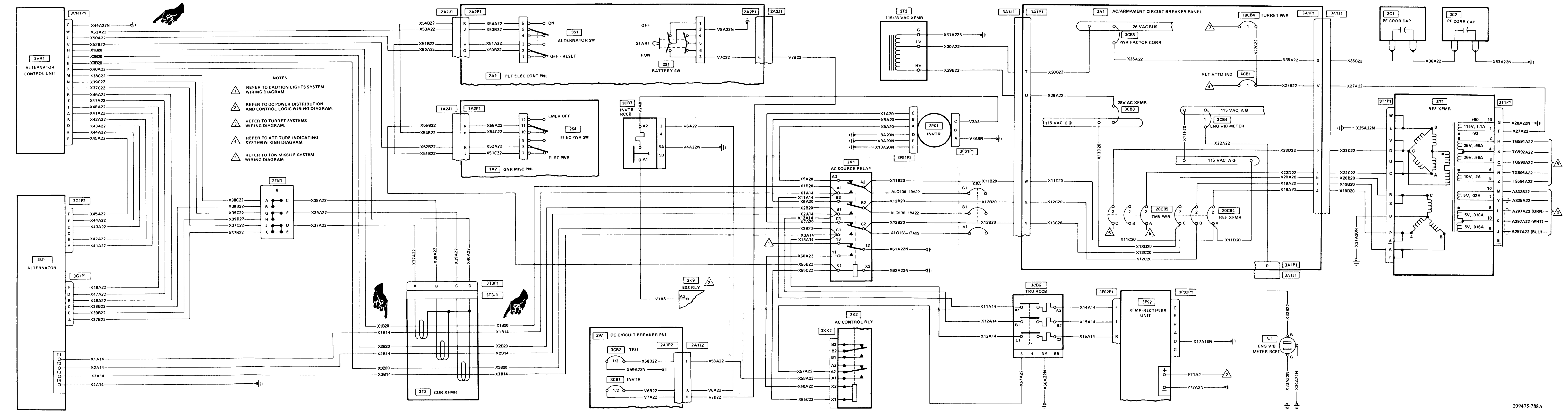

FO-98 AC Power system

209475-788A

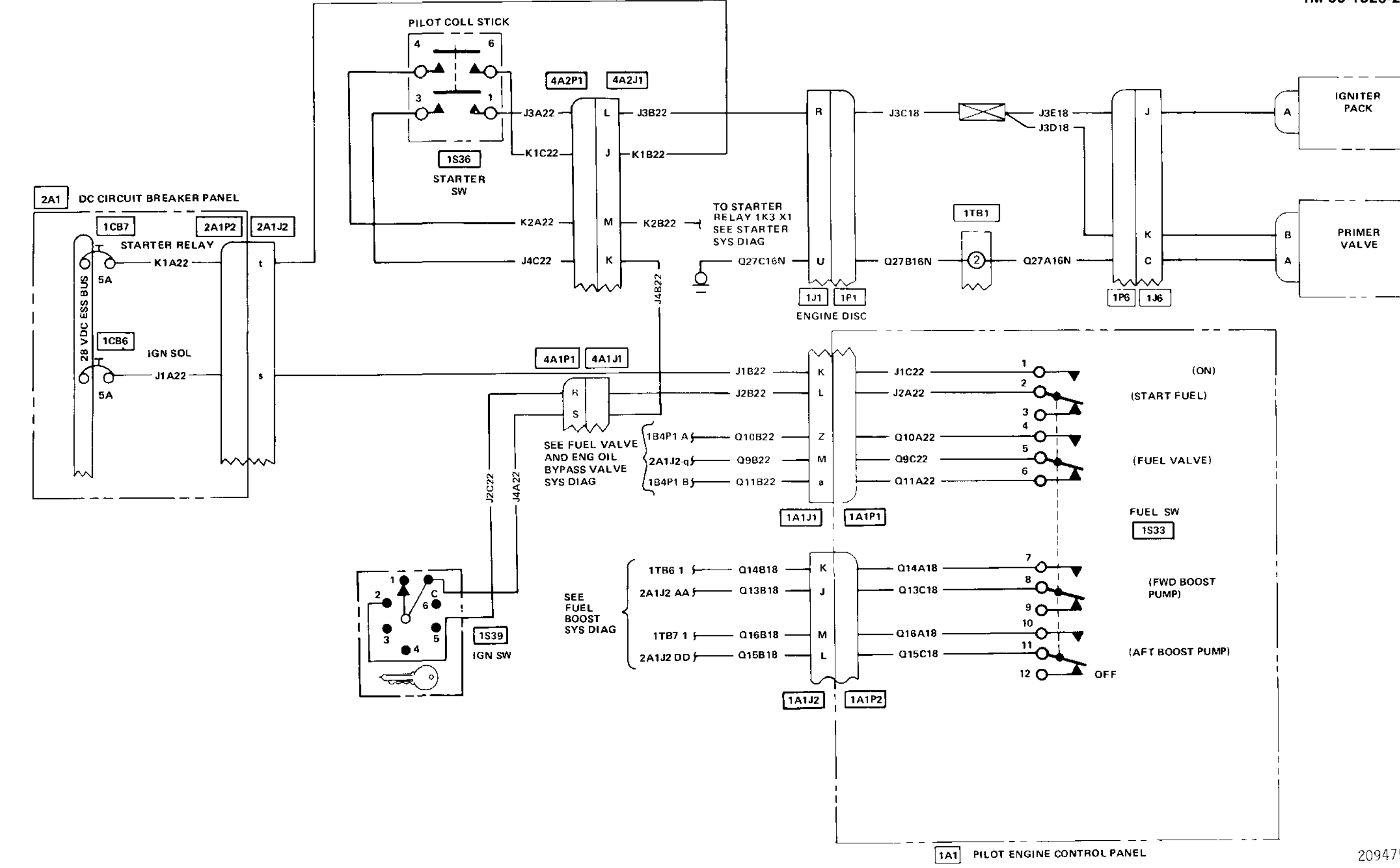

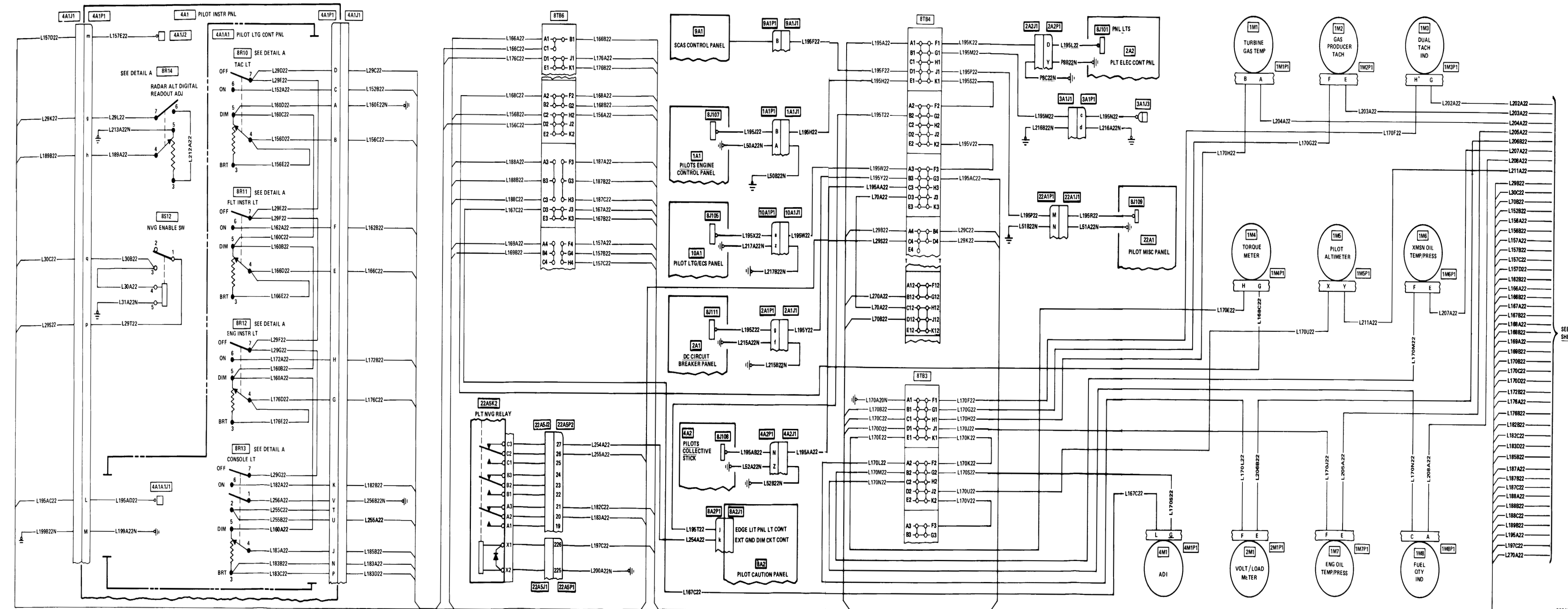

NOTE Where Sheet 2 is referenced see FO-101  
 Where Sheet 3 is referenced see FO-102  
 Where Sheet 4 is referenced see FO-103

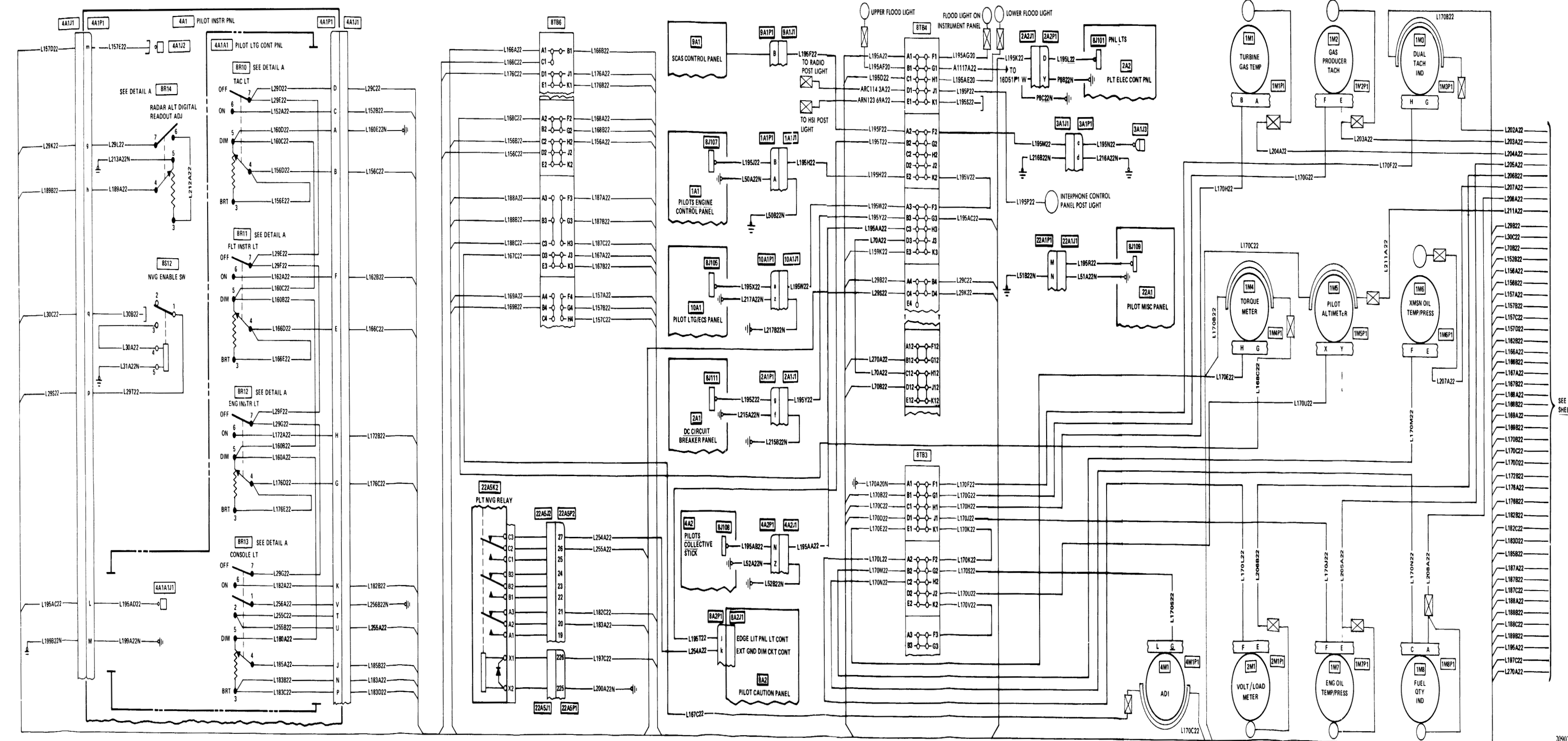

NOTE Where Sheet 2 is referenced see FO-101 1  
 Where Sheet 3 is referenced see FO-102 1.  
 Where Sheet 4 is referenced see FO-103



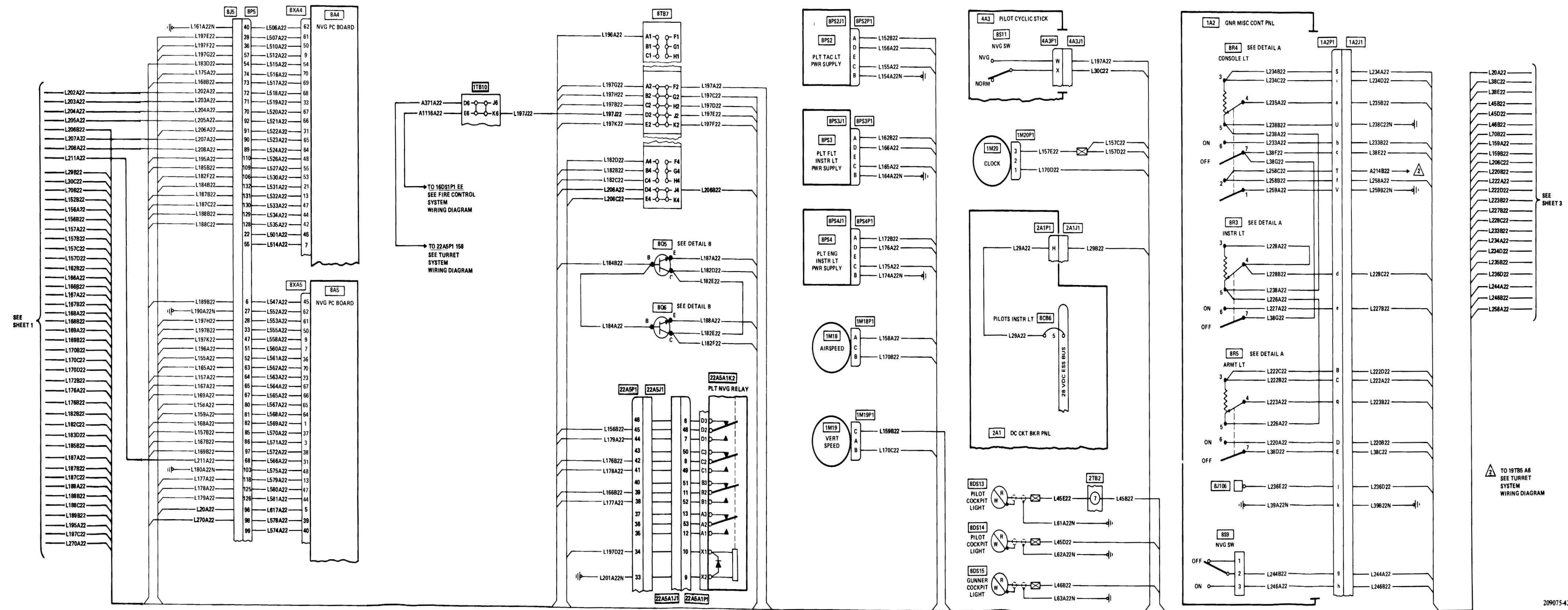

SEE SHEET 1

TO 16D51P1 EE  
SEE FIRE CONTROL  
SYSTEM  
WIRING DIAGRAM

TO 22AS1P1 158  
SEE TURRET  
SYSTEM  
WIRING DIAGRAM

SEE DETAIL B

SEE DETAIL B

NOTE Where Sheet 1 is referenced see FO-100  
 Where Sheet 3 is referenced see FO-102  
 Where Sheet 4 is referenced see FO-103.

SEE SHEET 3

TO 19TR6 A6  
SEE TURRET  
SYSTEM  
WIRING DIAGRAM

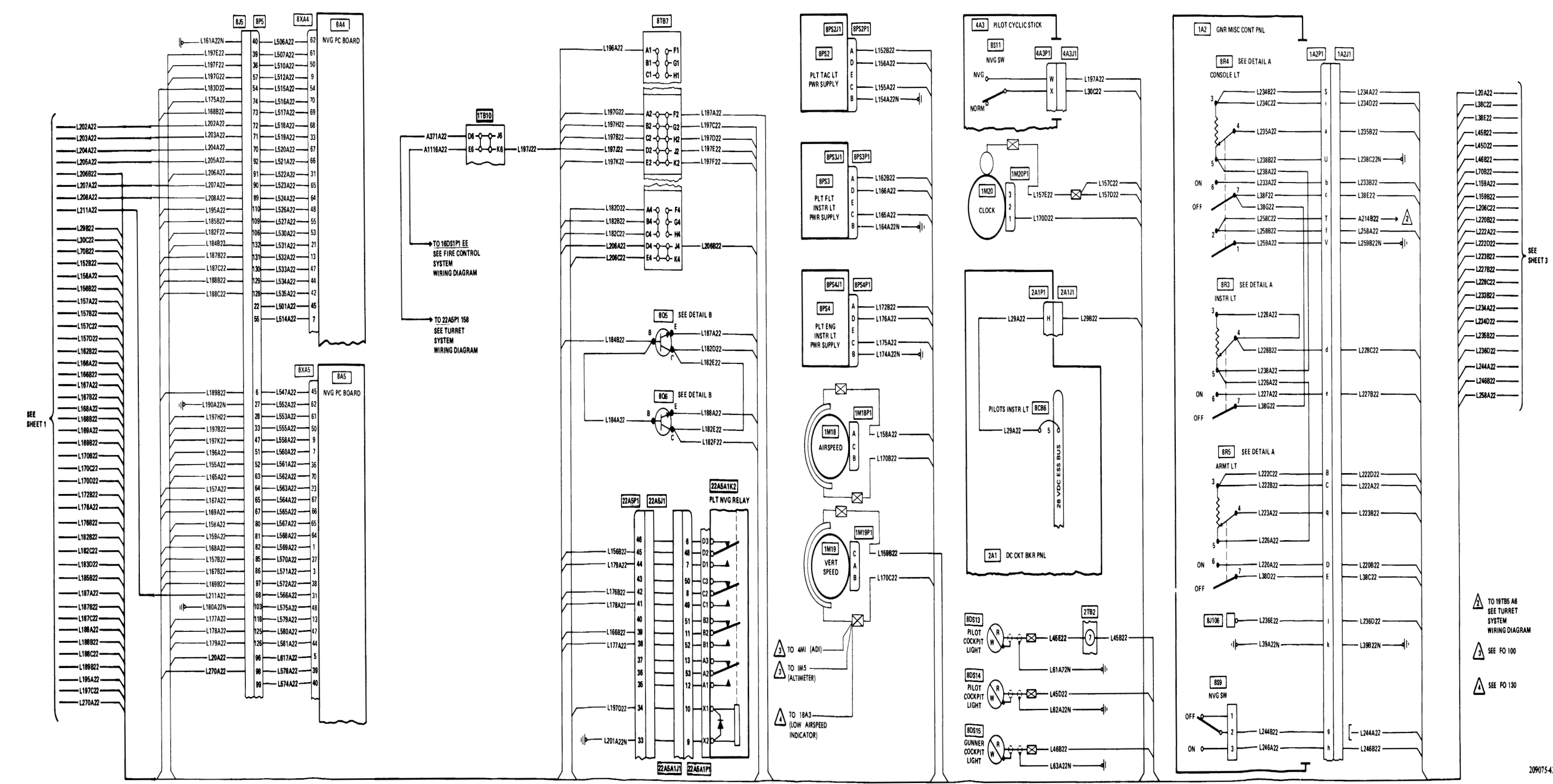

NOTE Where Sheet 1 is referenced see FO-100 1  
 Where Sheet 3 is referenced see FO-102 1  
 Where Sheet 4 is referenced see FO-103.

FO-101 1 Interior Lights System (After WMO 55-1520-236-50-4)  
 Change 5 FO-101.1

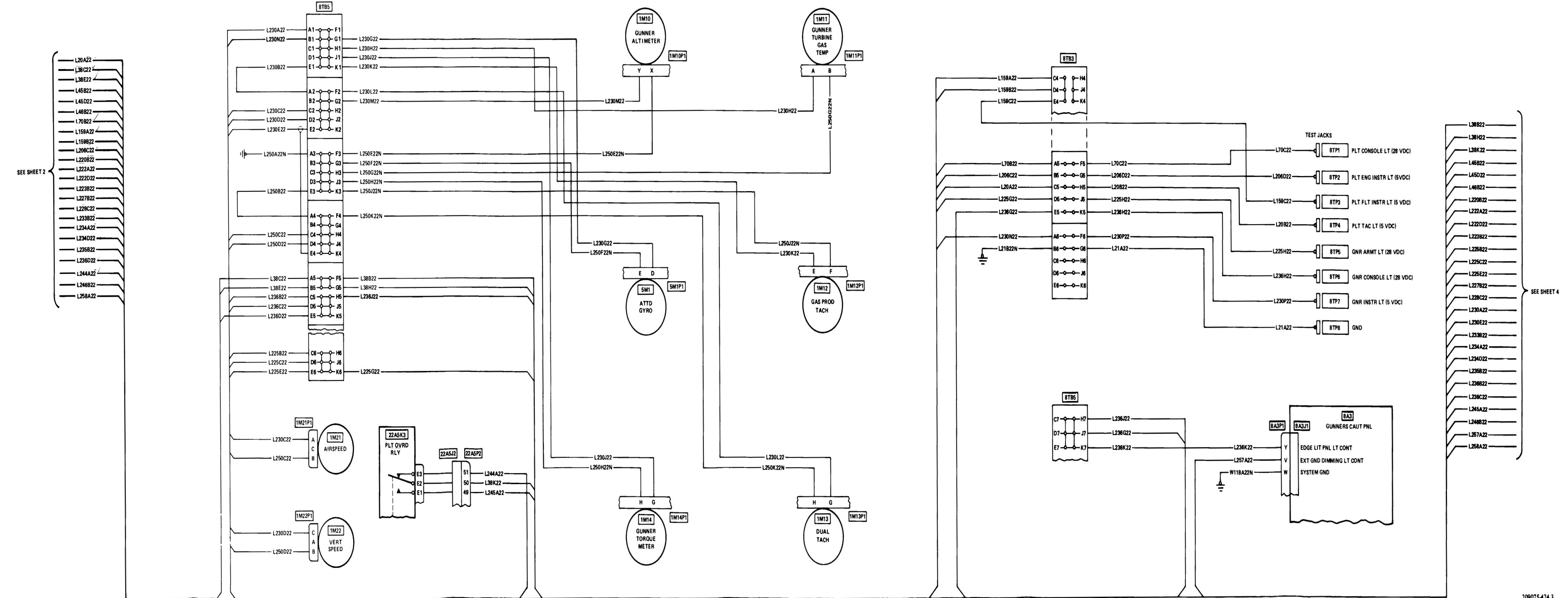

SEE SHEET 2

SEE SHEET 4

NOTE Where Sheet 1 is referenced see FO-100.  
 Where Sheet 2 is referenced see FO-101  
 Where Sheet 4 is referenced see FO-103

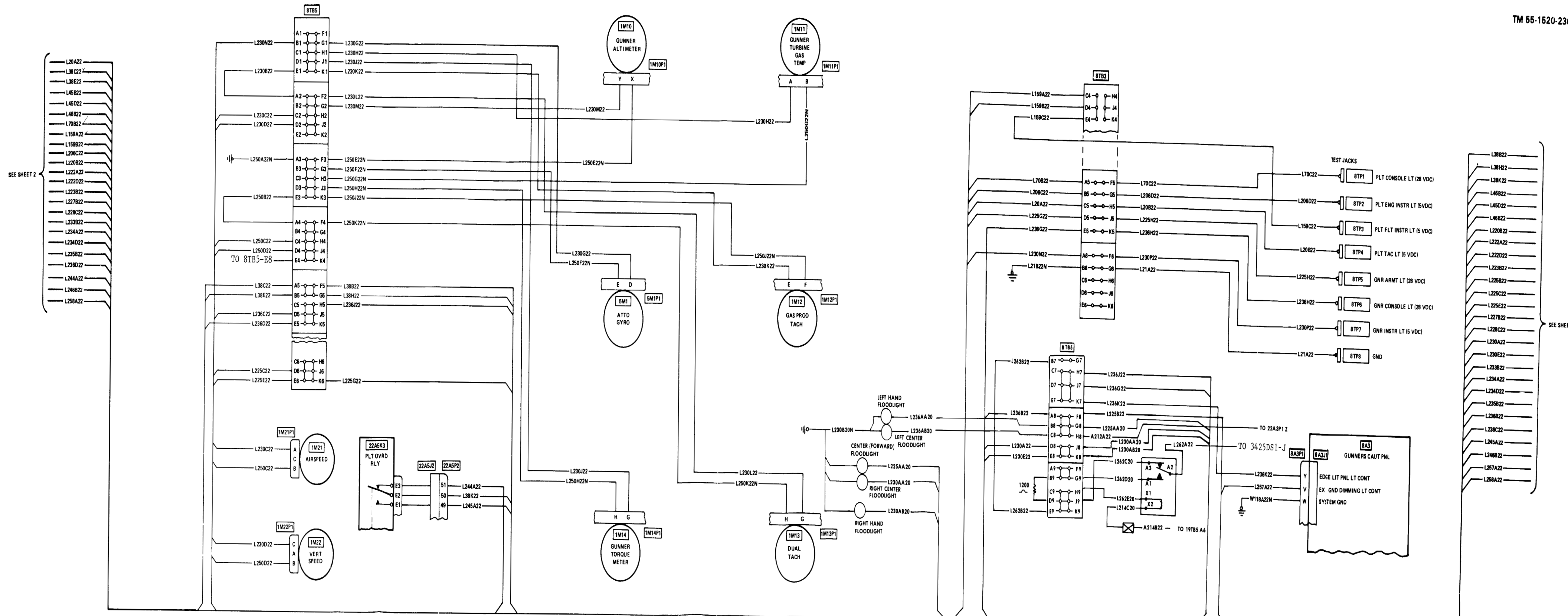

109075-424 3

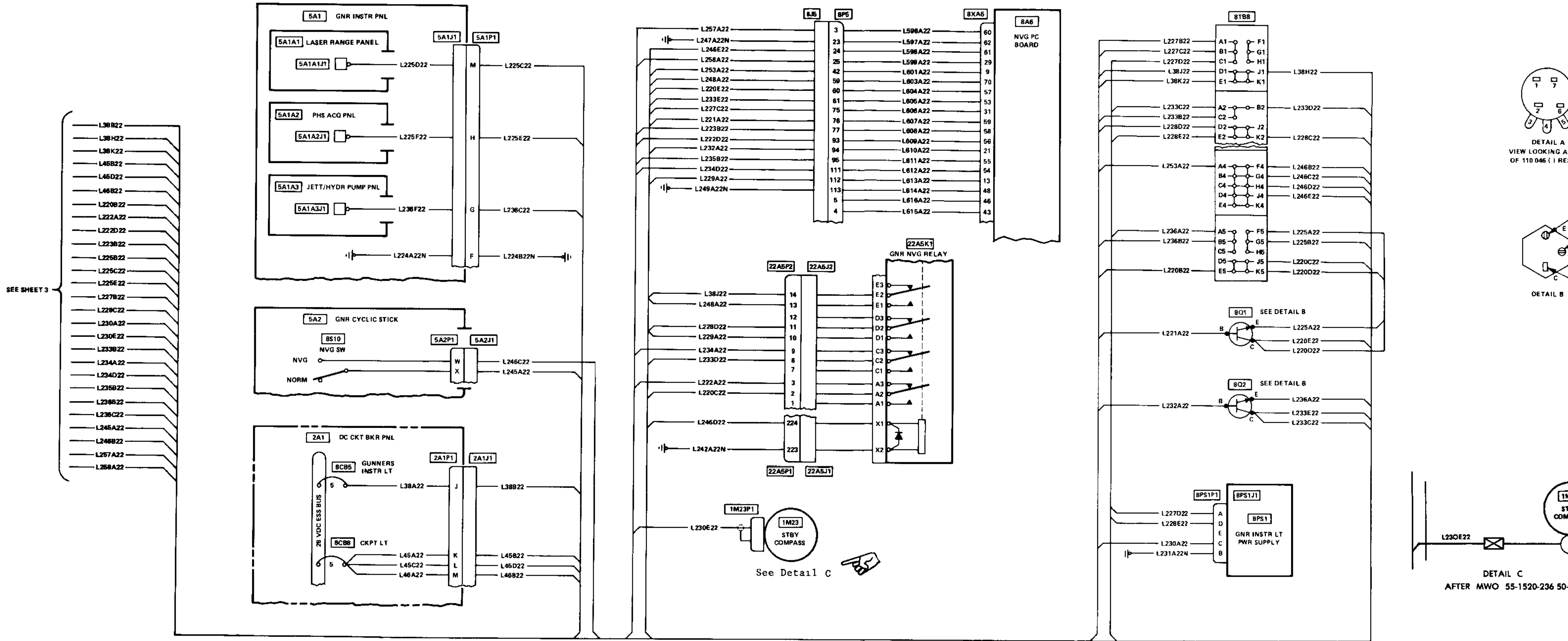

NOTE Where Sheet 1 is referenced see FO-100  
 Where Sheet 2 is referenced see FO-101  
 Where Sheet 3 is referenced see FO-102

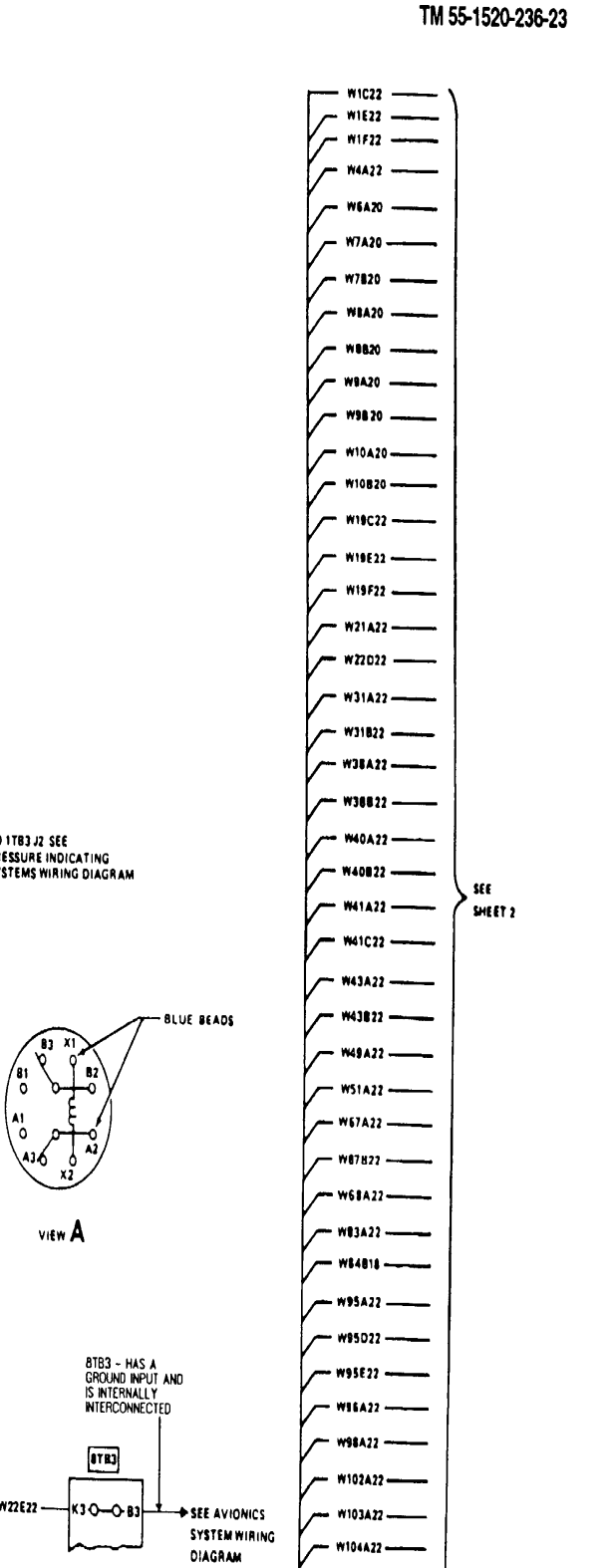
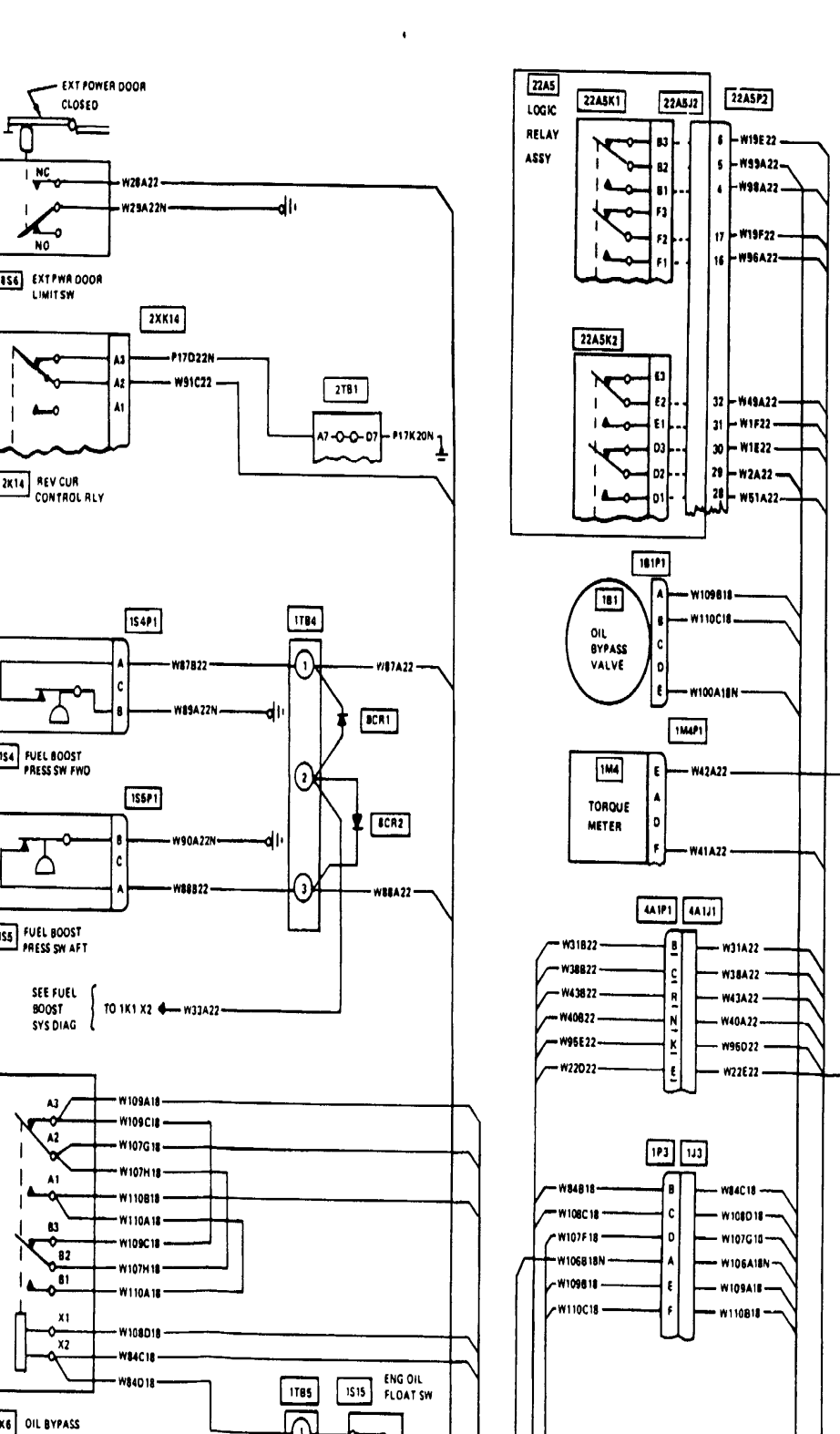
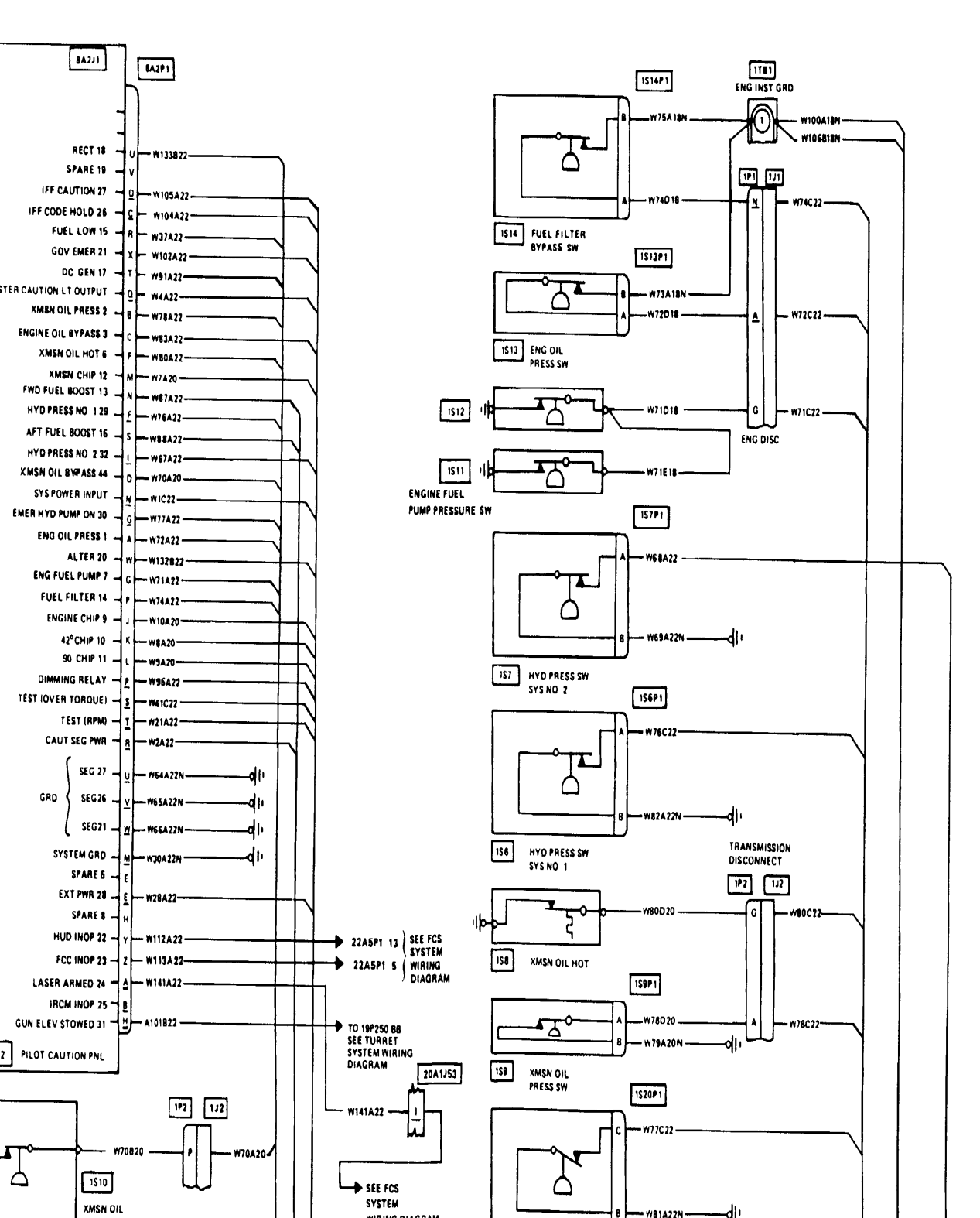
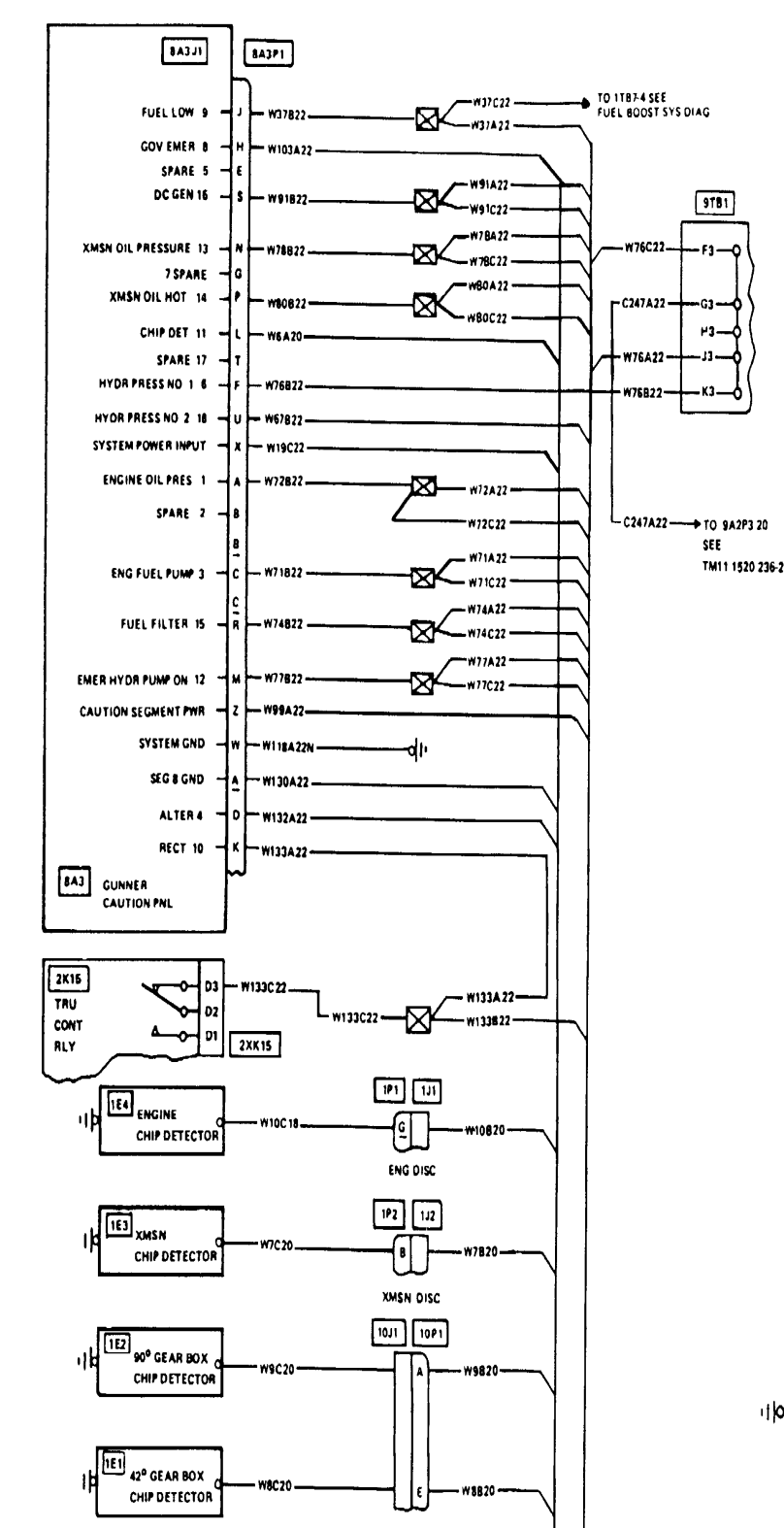
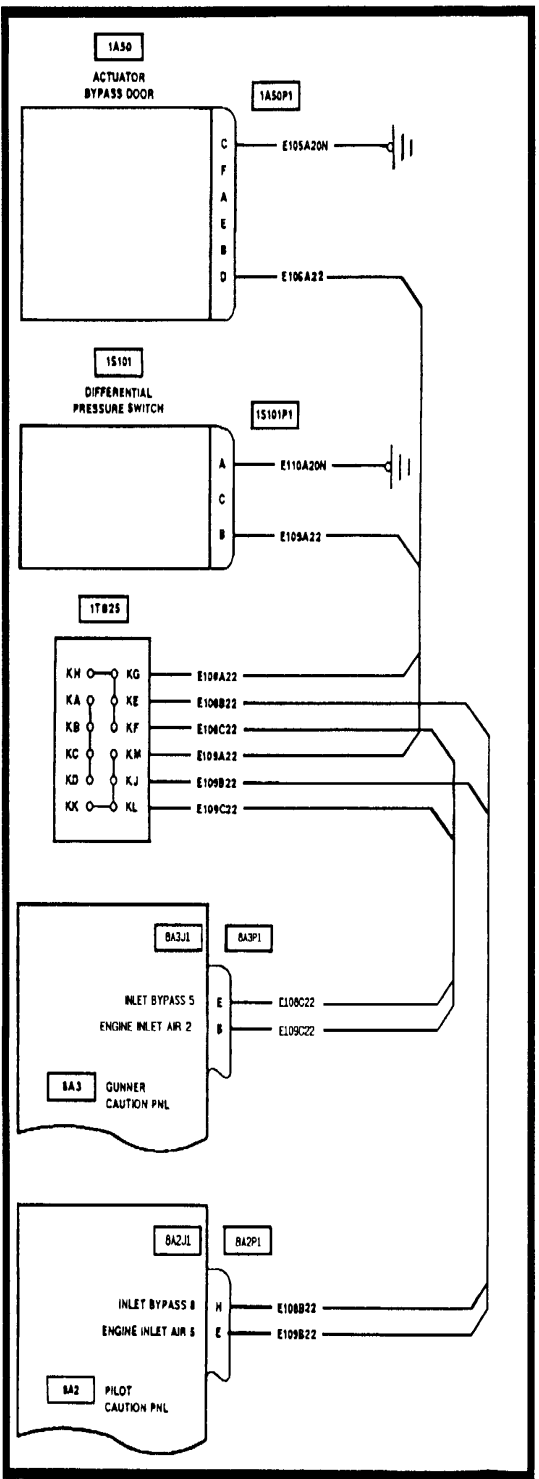

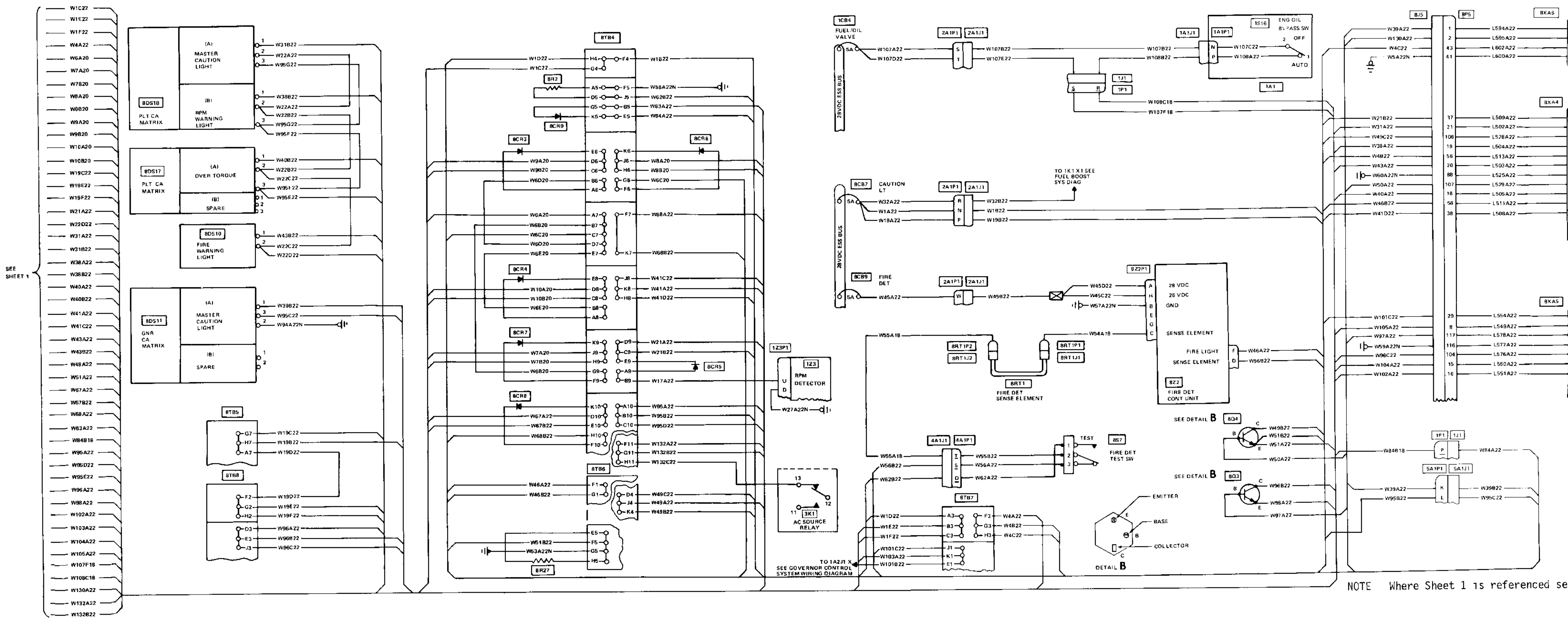

SEE SHEET 1

NOTE Where Sheet 1 is referenced see

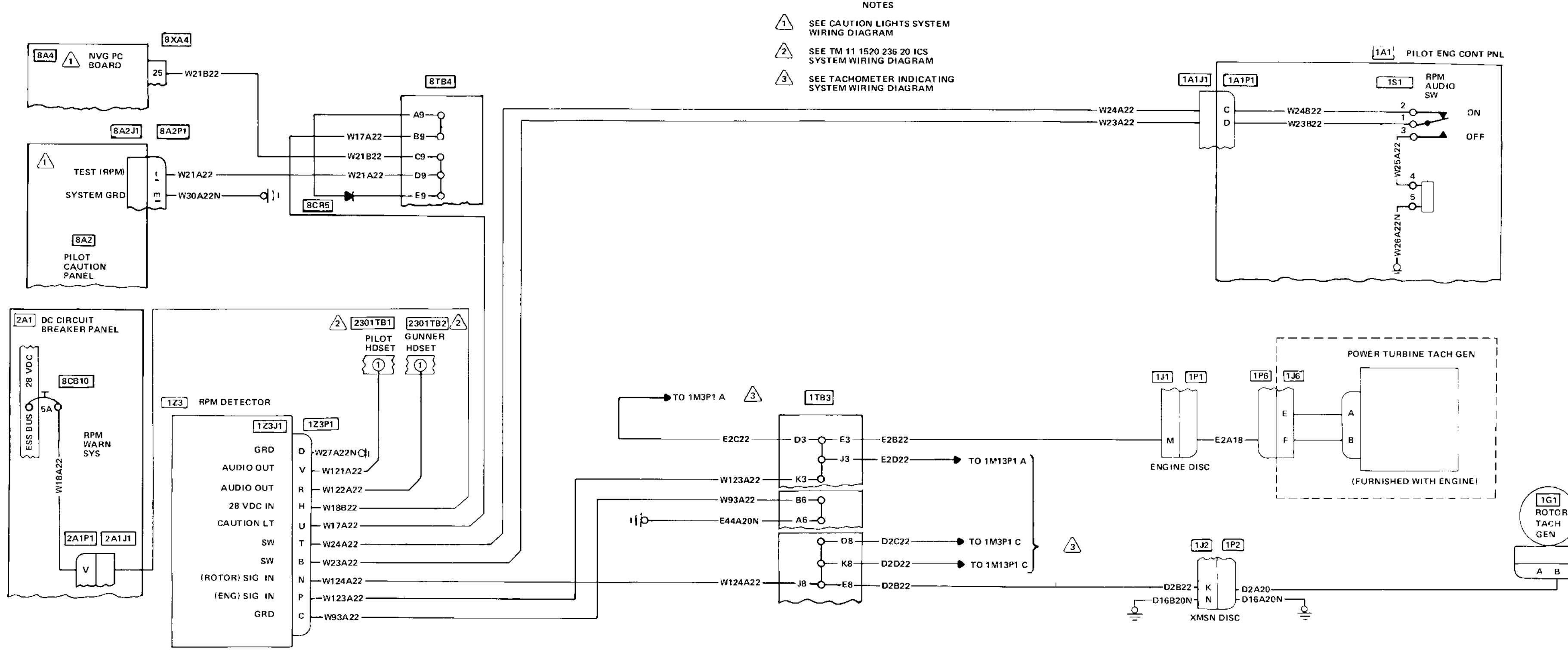

- NOTES
- 1 SEE CAUTION LIGHTS SYSTEM WIRING DIAGRAM
  - 2 SEE TM 11 1520 236 20 ICS SYSTEM WIRING DIAGRAM
  - 3 SEE TACHOMETER INDICATING SYSTEM WIRING DIAGRAM



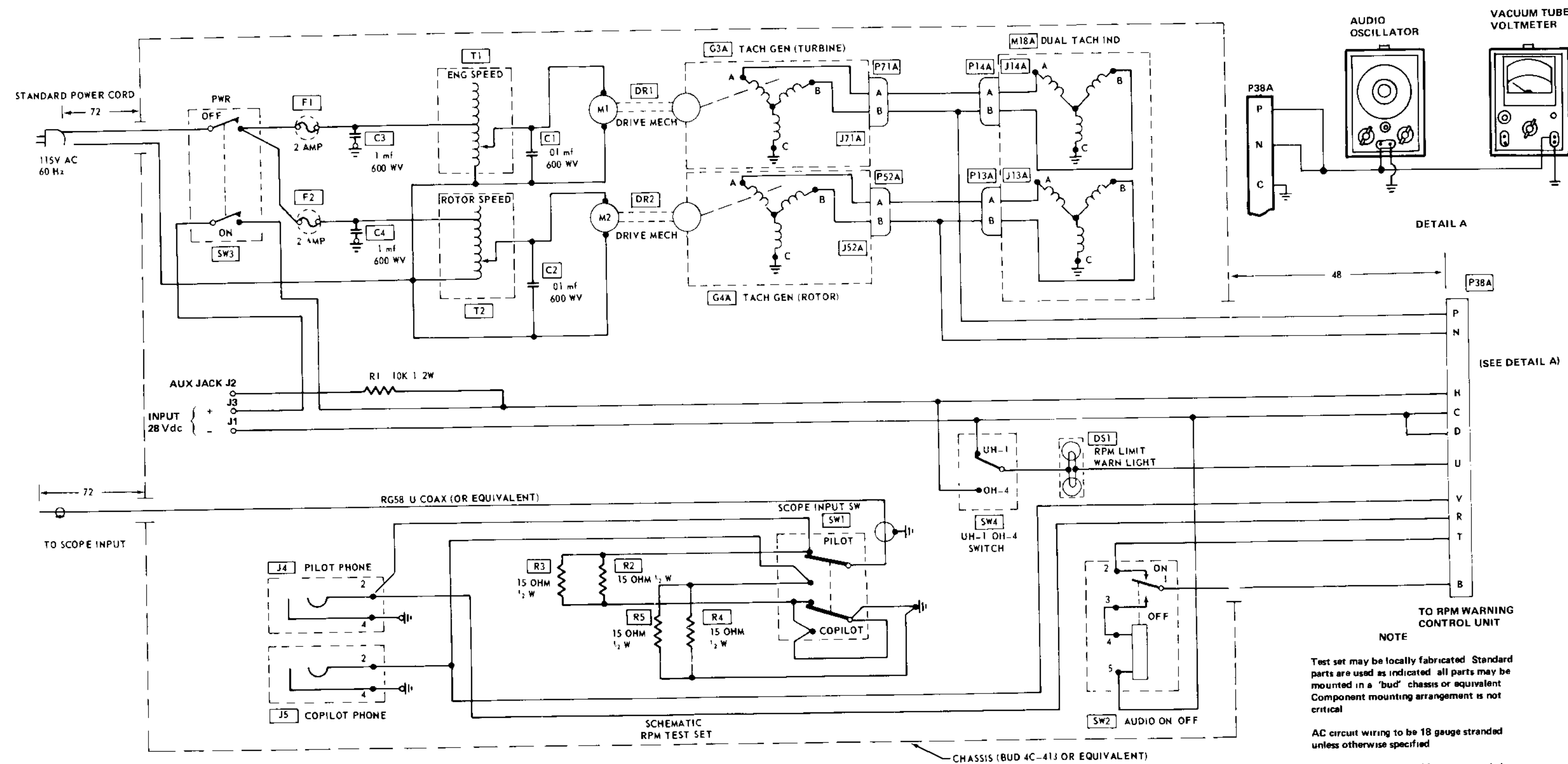

NOTE  
 Test set may be locally fabricated. Standard parts are used as indicated. All parts may be mounted in a 'bud' chassis or equivalent. Component mounting arrangement is not critical.  
 AC circuit wiring to be 18 gauge stranded unless otherwise specified.  
 DC circuit wiring to be 22 gauge stranded unless otherwise specified.

FREQ HZ	VRMS	ENG RPM	RO
66.5	19.5	6200	
69.0	20.0	6400	
73.5	22.0	6800	
76.0	22.5	7000	

ID CODE	NOMENCLATURE	
C1 C2	Line Filter 01 mf 600 WV	(
C3 C4	Line Filter 1 mf 600 WV	(
DR1 DR2	Rubber Flex Tube	R
DS1	Korry Light (033 0861 001)	(
F1 F2	Fuse Holder	H
G3A	Tach Generator (MIL G26611)	T
G4A	Tach Generator (MIL G26611)	T
J1 J2 J3	Banana Jack	S
J4 J5	Phone Jack	0
M1 M2	Tach Gen Drive Motor - Dayton Mod 2M037 - Ball Bearing 1/4 Shaft 1/10 HP 8000 RPM 115Vac 60 Hz	
M18A	Dual Tach Indicator - GE 8DJ67-BC Sub 1	(
P13A	Plug Dual Tach Indicator	M
P14A	Plug Dual Tach Indicator	M
P38A	Plug Eng RPM Warning Control	M
P52A	Plug Tach Generator	M
P71A	Plug Tach Generator	M
R1	Resistor 10K OHM 1/2W Carbon	(
R2 R3	Resistor 15 OHM 1/2W Carbon	(
R4 R5	Resistor 15 OHM 1/2W Carbon	(
SW1	Switch Scope Input	M
SW2	Switch Audio On/Off (Micro)	5
SW3	Switch Power On/Off	M
T1 T2	Speed Control - Power Stat Superior Electric Co (0 140Vac 60 Hz)	T

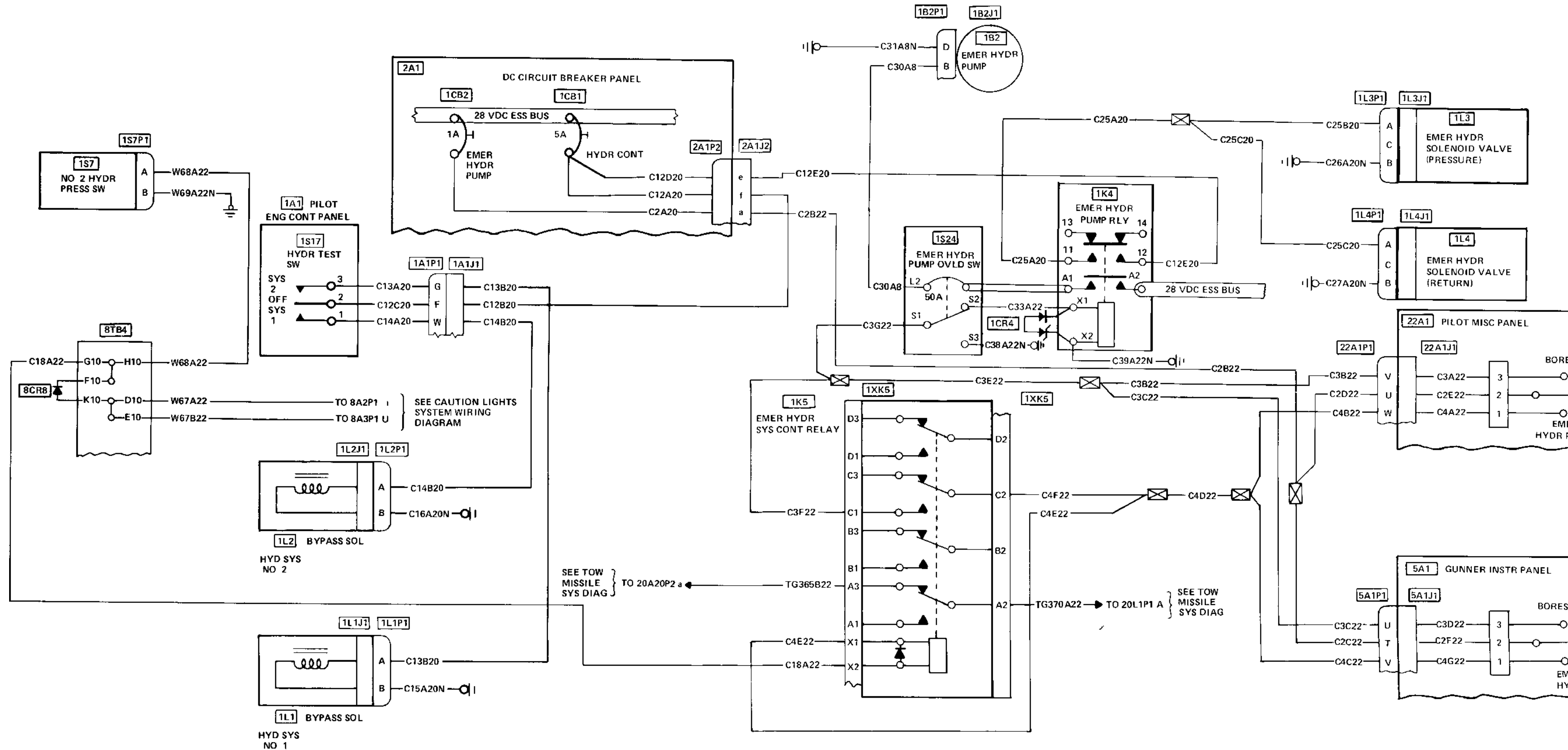



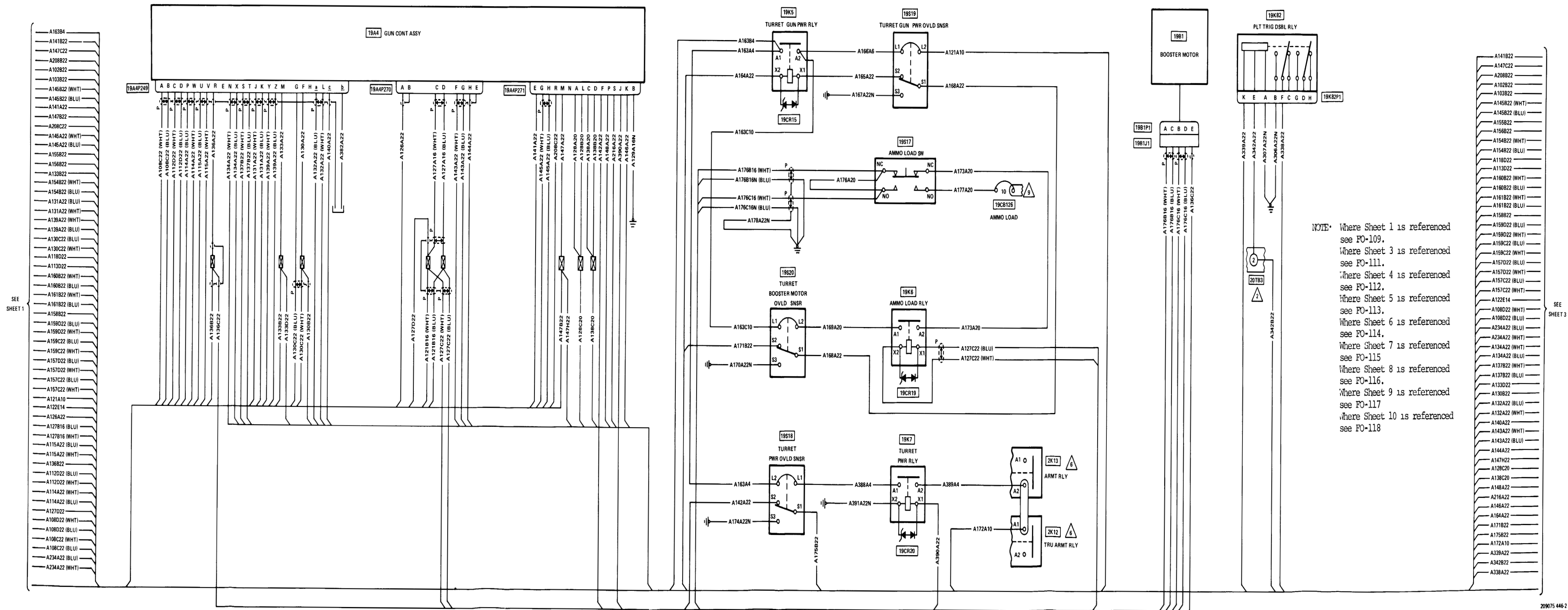

- A16384
- A14182Z
- A20882Z
- A10282Z
- A10382Z
- A14582Z (WHT)
- A141A2Z
- A14782Z
- A208C2Z
- A145A2Z (WHT)
- A145A2Z (BLU)
- A15882Z
- A13382Z
- A15482Z (WHT)
- A15482Z (BLU)
- A131A2Z (WHT)
- A138A2Z (BLU)
- A130C2Z (BLU)
- A11802Z
- A11802Z
- A19382Z (WHT)
- A16982Z (BLU)
- A16182Z (WHT)
- A16182Z (BLU)
- A15882Z
- A15902Z (BLU)
- A15902Z (WHT)
- A158C2Z (BLU)
- A158C2Z (WHT)
- A15702Z (BLU)
- A15702Z (WHT)
- A157C2Z (BLU)
- A157C2Z (WHT)
- A171A10
- A122E14
- A126A2Z
- A127816 (BLU)
- A127816 (WHT)
- A115A2Z (BLU)
- A115A2Z (WHT)
- A13682Z
- A112202Z (BLU)
- A112202Z (WHT)
- A114A2Z (WHT)
- A114A2Z (BLU)
- A12702Z
- A10802Z (WHT)
- A10802Z (BLU)
- A108C2Z (WHT)
- A108C2Z (BLU)
- A234A2Z (BLU)
- A234A2Z (WHT)

SEE SHEET 1

- A14182Z
- A147C2Z
- A20882Z
- A10282Z
- A10382Z
- A14582Z (WHT)
- A14582Z (BLU)
- A15882Z
- A15882Z
- A15482Z (WHT)
- A15482Z (BLU)
- A11802Z
- A11302Z
- A16082Z (BLU)
- A16182Z (WHT)
- A16182Z (BLU)
- A15882Z
- A15902Z (BLU)
- A15902Z (WHT)
- A158C2Z (BLU)
- A15702Z (BLU)
- A15702Z (WHT)
- A157C2Z (BLU)
- A122E14
- A10802Z (WHT)
- A10802Z (BLU)
- A234A2Z (BLU)
- A234A2Z (WHT)
- A134A2Z (WHT)
- A134A2Z (BLU)
- A13782Z (WHT)
- A13782Z (BLU)
- A13302Z
- A132A2Z (BLU)
- A13082Z
- A140A2Z
- A143A2Z (WHT)
- A143A2Z (BLU)
- A144A2Z
- A147H2Z
- A128C20
- A138C20
- A148A2Z
- A216A2Z
- A146A2Z
- A164A2Z
- A17182Z
- A172A10
- A339A2Z
- A34282Z
- A338A2Z

SEE SHEET 3

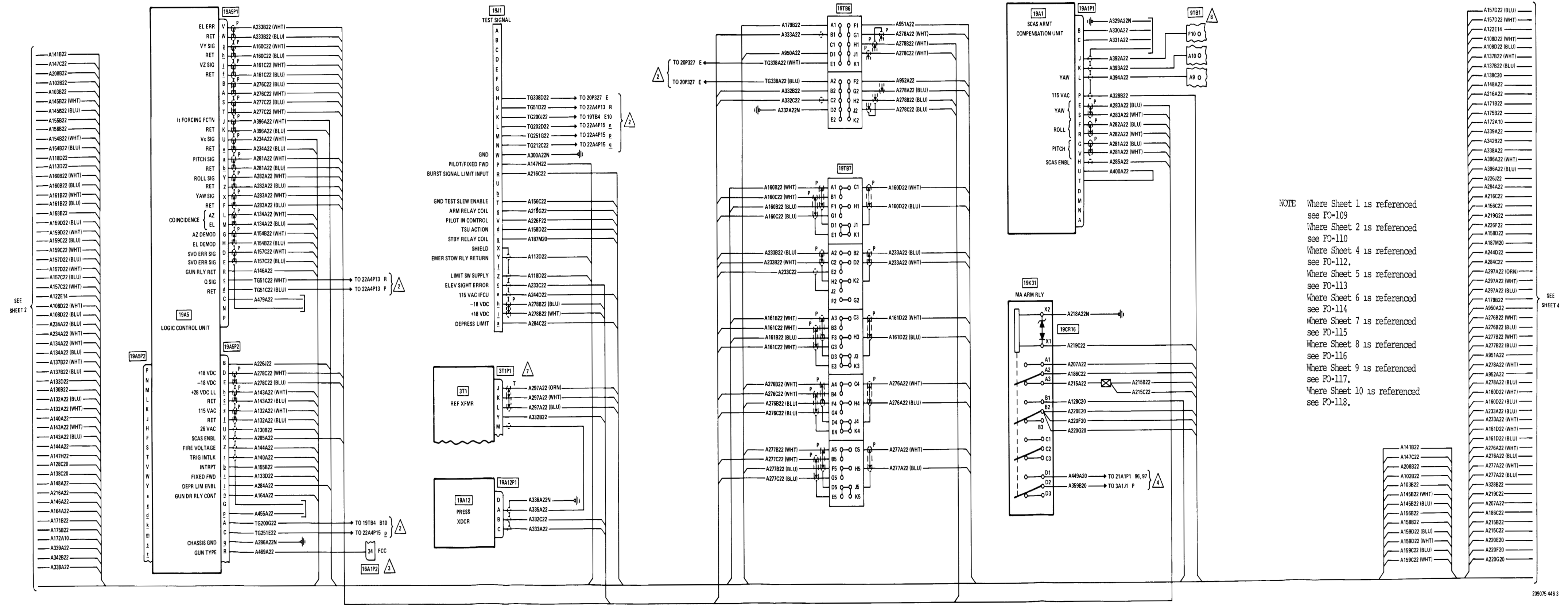

SEE SHEET 2

SEE SHEET 4

NOTE Where Sheet 1 is referenced see FO-109  
 Where Sheet 2 is referenced see FO-110  
 Where Sheet 4 is referenced see FO-112  
 Where Sheet 5 is referenced see FO-113  
 Where Sheet 6 is referenced see FO-114  
 Where Sheet 7 is referenced see FO-115  
 Where Sheet 8 is referenced see FO-116  
 Where Sheet 9 is referenced see FO-117  
 Where Sheet 10 is referenced see FO-118.

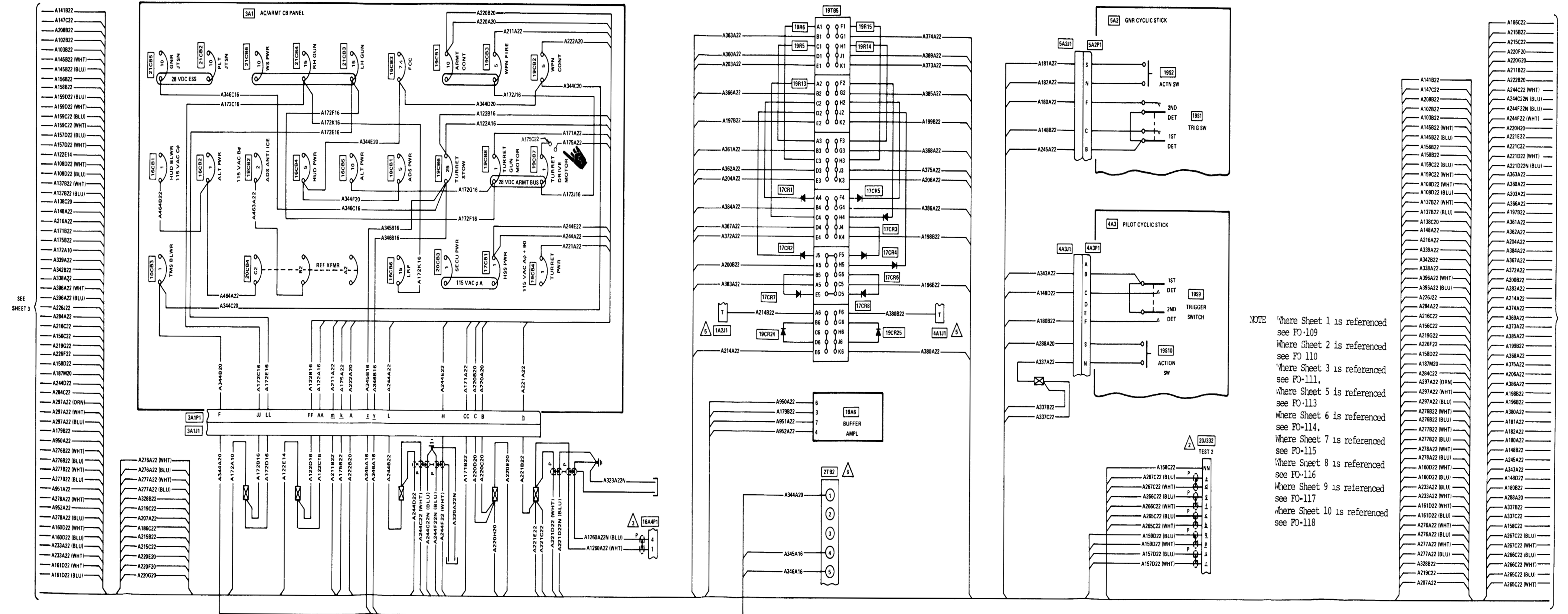

SEE SHEET 1

SEE SHEETS

NOTE Where Sheet 1 is referenced see FO-109  
 Where Sheet 2 is referenced see FO-110  
 Where Sheet 3 is referenced see FO-111,  
 where Sheet 5 is referenced see FO-113  
 Where Sheet 6 is referenced see FO-114,  
 Where Sheet 7 is referenced see FO-115  
 Where Sheet 8 is referenced see FO-116  
 Where Sheet 9 is referenced see FO-117  
 Where Sheet 10 is referenced see FO-118



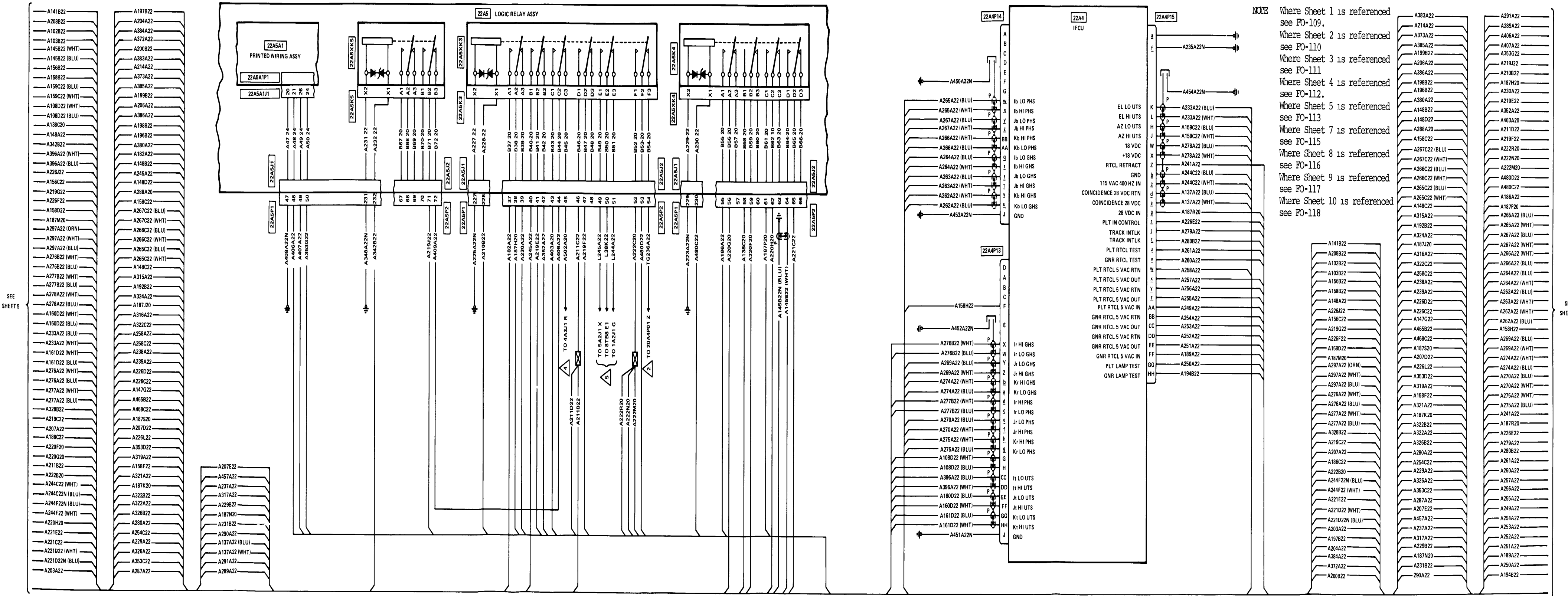

NOTE  
 Where Sheet 1 is referenced  
 see FO-109.  
 Where Sheet 2 is referenced  
 see FO-110.  
 Where Sheet 3 is referenced  
 see FO-111.  
 Where Sheet 4 is referenced  
 see FO-112.  
 Where Sheet 5 is referenced  
 see FO-113.  
 Where Sheet 7 is referenced  
 see FO-115.  
 Where Sheet 8 is referenced  
 see FO-116.  
 Where Sheet 9 is referenced  
 see FO-117.  
 Where Sheet 10 is referenced  
 see FO-118.

SEE SHEET 5

SEE SHEET 7



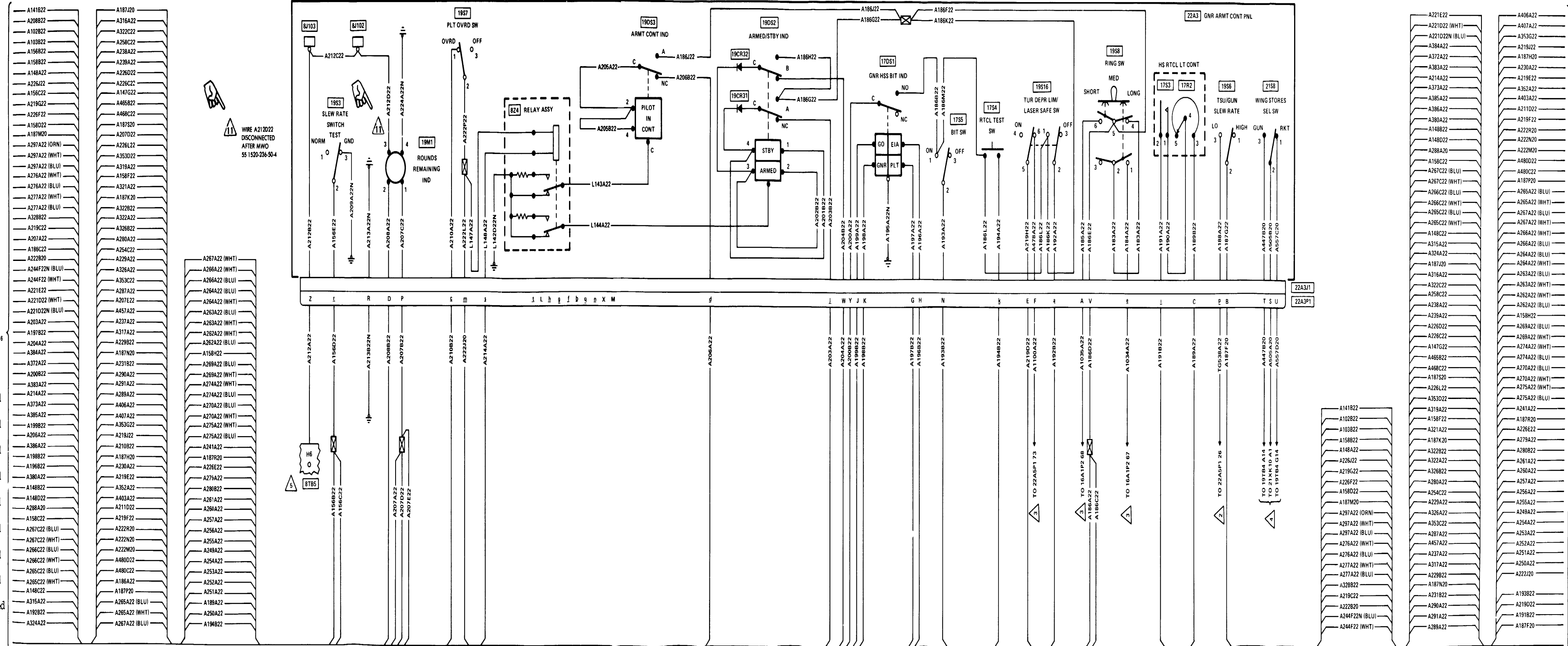

NOTE Where Sheet 1 is referenced see FO-109,  
 Where Sheet 2 is referenced see FO-110  
 Where Sheet 3 is referenced see FO-111  
 Where Sheet 4 is referenced see FO-112  
 Where Sheet 5 is referenced see FO-113,  
 Where Sheet 6 is referenced see FO-114  
 Where Sheet 8 is referenced see FO-116  
 Where Sheet 9 is referenced see FO-117  
 Where Sheet 10 is referenced see FO-118,

A1416Z2	A18720	A2674Z2 (WHT)
A2082Z2	A3164Z2	A2684Z2 (WHT)
A1028Z2	A322CZ2	A2684Z2 (BLU)
A1028Z2	A298CZ2	A2684Z2 (BLU)
A1568Z2	A2384Z2	A2684Z2 (BLU)
A1568Z2	A2384Z2	A2684Z2 (BLU)
A1484Z2	A268CZ2	A2684Z2 (BLU)
A2264Z2	A468CZ2	A2684Z2 (BLU)
A156CZ2	A19720	A2684Z2 (BLU)
A219CZ2	A468CZ2	A2684Z2 (BLU)
A226CZ2	A19720	A2684Z2 (BLU)
A180CZ2	A2070Z2	A2684Z2 (BLU)
A18740	A2361Z2	A2684Z2 (BLU)
A2514Z2 (ORNI)	A3530Z2	A2684Z2 (BLU)
A2514Z2 (WHT)	A3184Z2	A2684Z2 (BLU)
A276A2Z2 (BLU)	A158FZ2	A2684Z2 (BLU)
A276A2Z2 (WHT)	A3214Z2	A2684Z2 (BLU)
A277A2Z2 (BLU)	A18720	A2684Z2 (BLU)
A277A2Z2 (WHT)	A3228Z2	A2684Z2 (BLU)
A278A2Z2 (BLU)	A3228Z2	A2684Z2 (BLU)
A278A2Z2 (WHT)	A3228Z2	A2684Z2 (BLU)
A279CZ2	A3288Z2	A2684Z2 (BLU)
A2074Z2	A2804Z2	A2684Z2 (BLU)
A186CZ2	A2804Z2	A2684Z2 (BLU)
A2228Z0	A254CZ2	A2684Z2 (BLU)
A244FZ2N (BLU)	A2684Z2	A2684Z2 (BLU)
A244FZ2 (WHT)	A363CZ2	A2684Z2 (BLU)
A2210Z2 (WHT)	A2674Z2	A2684Z2 (BLU)
A2210Z2 (BLU)	A2070Z2	A2684Z2 (BLU)
A203A2Z	A4574Z2	A2684Z2 (BLU)
A1918Z2	A2374Z2	A2684Z2 (BLU)
A204A2Z	A298CZ2	A2684Z2 (BLU)
A384A2Z	A18720	A2684Z2 (BLU)
A372A2Z	A2318Z2	A2684Z2 (BLU)
A208Z2	A2984Z2	A2684Z2 (BLU)
A383A2Z	A2914Z2	A2684Z2 (BLU)
A214A2Z	A2884Z2	A2684Z2 (BLU)
A373A2Z	A4064Z2	A2684Z2 (BLU)
A385A2Z	A4074Z2	A2684Z2 (BLU)
A1998Z2	A3530Z2	A2684Z2 (BLU)
A206A2Z	A219Z2	A2684Z2 (BLU)
A386A2Z	A2108Z2	A2684Z2 (BLU)
A1988Z2	A18720	A2684Z2 (BLU)
A1968Z2	A230A2Z	A2684Z2 (BLU)
A380A2Z	A219E2Z	A2684Z2 (BLU)
A1488Z2	A3524Z2	A2684Z2 (BLU)
A1480Z2	A4034Z2	A2684Z2 (BLU)
A288A20	A2110Z2	A2684Z2 (BLU)
A158CZ2	A219FZ2	A2684Z2 (BLU)
A267CZ2 (BLU)	A222R20	A2684Z2 (BLU)
A267CZ2 (WHT)	A222N20	A2684Z2 (BLU)
A266CZ2 (BLU)	A222M20	A2684Z2 (BLU)
A266CZ2 (WHT)	A480DZ2	A2684Z2 (BLU)
A265CZ2 (BLU)	A480CZ2	A2684Z2 (BLU)
A265CZ2 (WHT)	A1864Z2	A2684Z2 (BLU)
A148CZ2	A187P20	A2684Z2 (BLU)
A315A2Z	A265A2Z (BLU)	A2684Z2 (BLU)
A1928Z2	A265A2Z (WHT)	A2684Z2 (BLU)
A324A2Z	A267A2Z (BLU)	A2684Z2 (BLU)

SEE SHEET 6

SEE SHEET 8

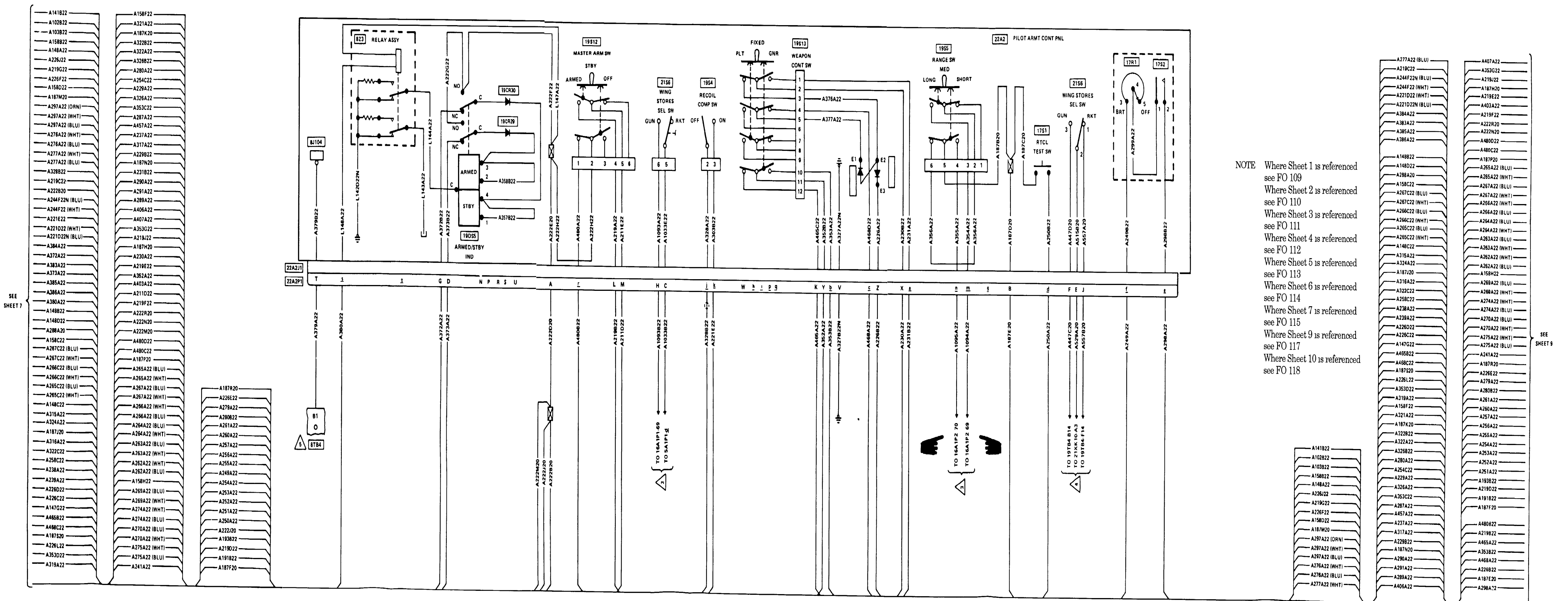

A1410Z2	A158F22
A1020Z2	A321A22
A1030Z2	A187K20
A1580Z2	A3220Z2
A148A22	A327A22
A226Z22	A3280Z2
A219G22	A280A22
A226F22	A254C22
A158C22	A229A22
A187W20	A326A22
A297A22 (ORNI)	A353C22
A297A22 (WHT)	A287A22
A297A22 (BLU)	A457A22
A276A22 (WHT)	A237A22
A276A22 (BLU)	A317A22
A277A22 (WHT)	A2290Z2
A277A22 (BLU)	A187N20
A3280Z2	A2310Z2
A219C22	A290A22
A2220Z20	A291A22
A244F22N (BLU)	A289A22
A244F22 (WHT)	A406A22
A221E22	A407A22
A2210Z2 (WHT)	A353G22
A2210Z2 (BLU)	A218Z22
A38A22	A187H20
A377A22	A230A22
A383A22	A219E22
A373A22	A158H22
A385A22	A362A22
A386A22	A403A22
A380A22	A2110Z2
A1480Z2	A219F22
A1480Z2	A222R20
A280A20	A222N20
A158C22	A480C22
A287C22 (BLU)	A187P20
A287C22 (WHT)	A285A22 (BLU)
A286C22 (BLU)	A285A22 (WHT)
A285C22 (BLU)	A267A22 (BLU)
A285C22 (WHT)	A267A22 (WHT)
A148C22	A266A22 (WHT)
A315A22	A286A22 (BLU)
A324A22	A2800Z2
A187J20	A281A22
A316A22	A290A22
A323C22	A257A22
A258C22	A256A22
A258A22	A255A22
A258Z22	A248A22
A258Z22	A254A22
A258Z22	A253A22
A1410Z2	A252A22
A465Z22	A251A22
A480Z22	A250A22
A187R20	A222J20
A226L22	A1930Z2
A353D22	A219D22
A319A22	A1918Z2
	A187T20

A187R20
A228E22
A279A22
A2800Z2
A281A22
A290A22
A257A22
A256A22
A255A22
A248A22
A254A22
A253A22
A252A22
A251A22
A250A22
A222J20
A1930Z2
A219D22
A1918Z2
A187T20

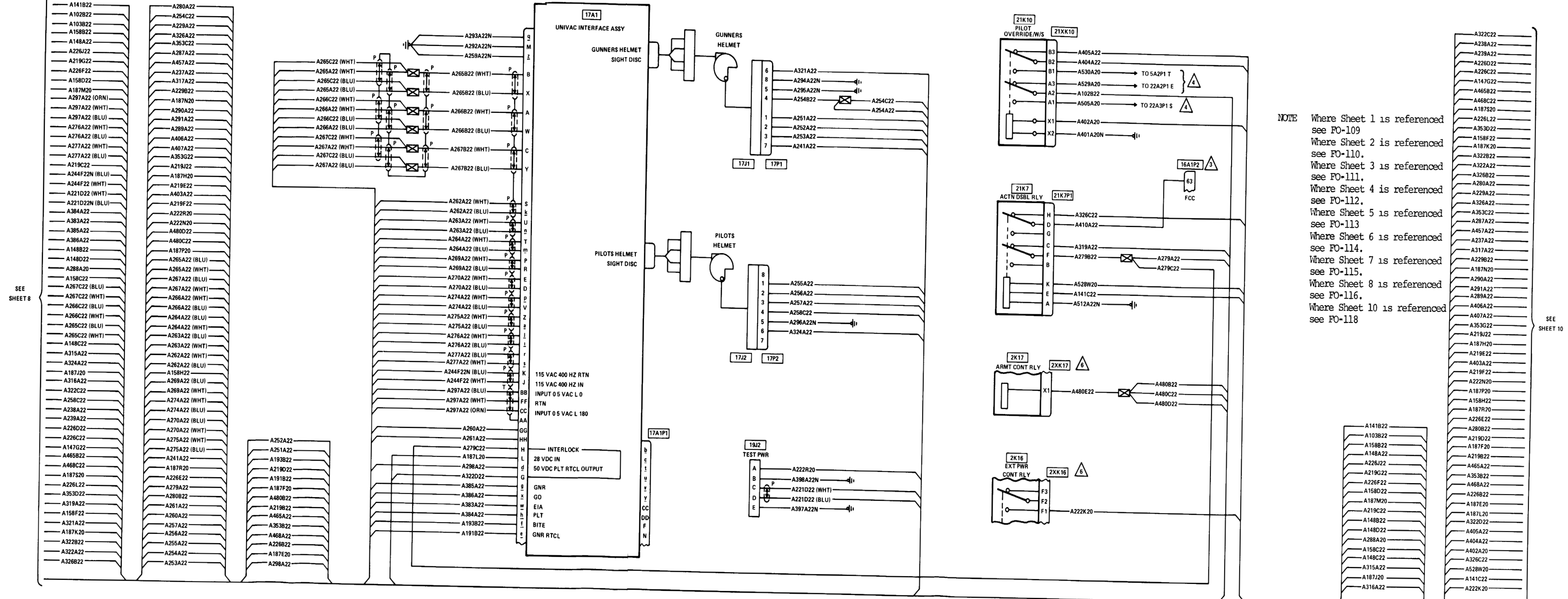

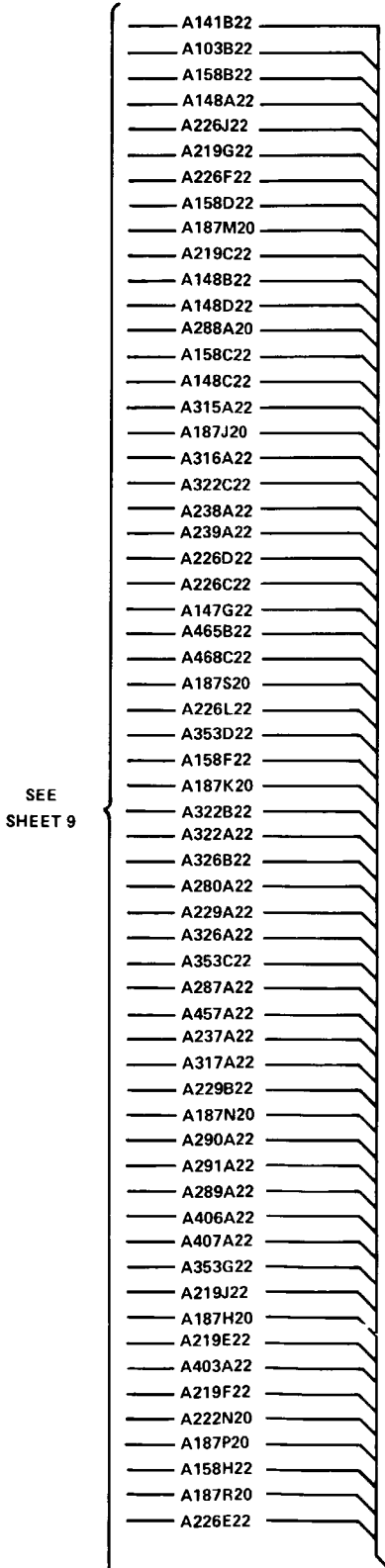

SEE SHEET 9

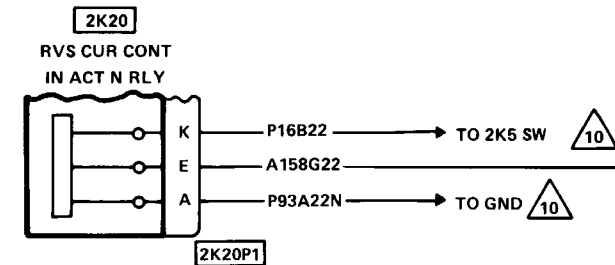

NOTE Where Sheet 1 is referenced see FO-109  
 Where Sheet 2 is referenced see FO-110  
 Where Sheet 3 is referenced see FO-111  
 Where Sheet 4 is referenced see FO-112.  
 Where Sheet 5 is referenced see FO-113  
 Where Sheet 6 is referenced see FO-114  
 Where Sheet 7 is referenced see FO-115  
 Where Sheet 8 is referenced see FO-116.  
 Where Sheet 9 is referenced see FO-117

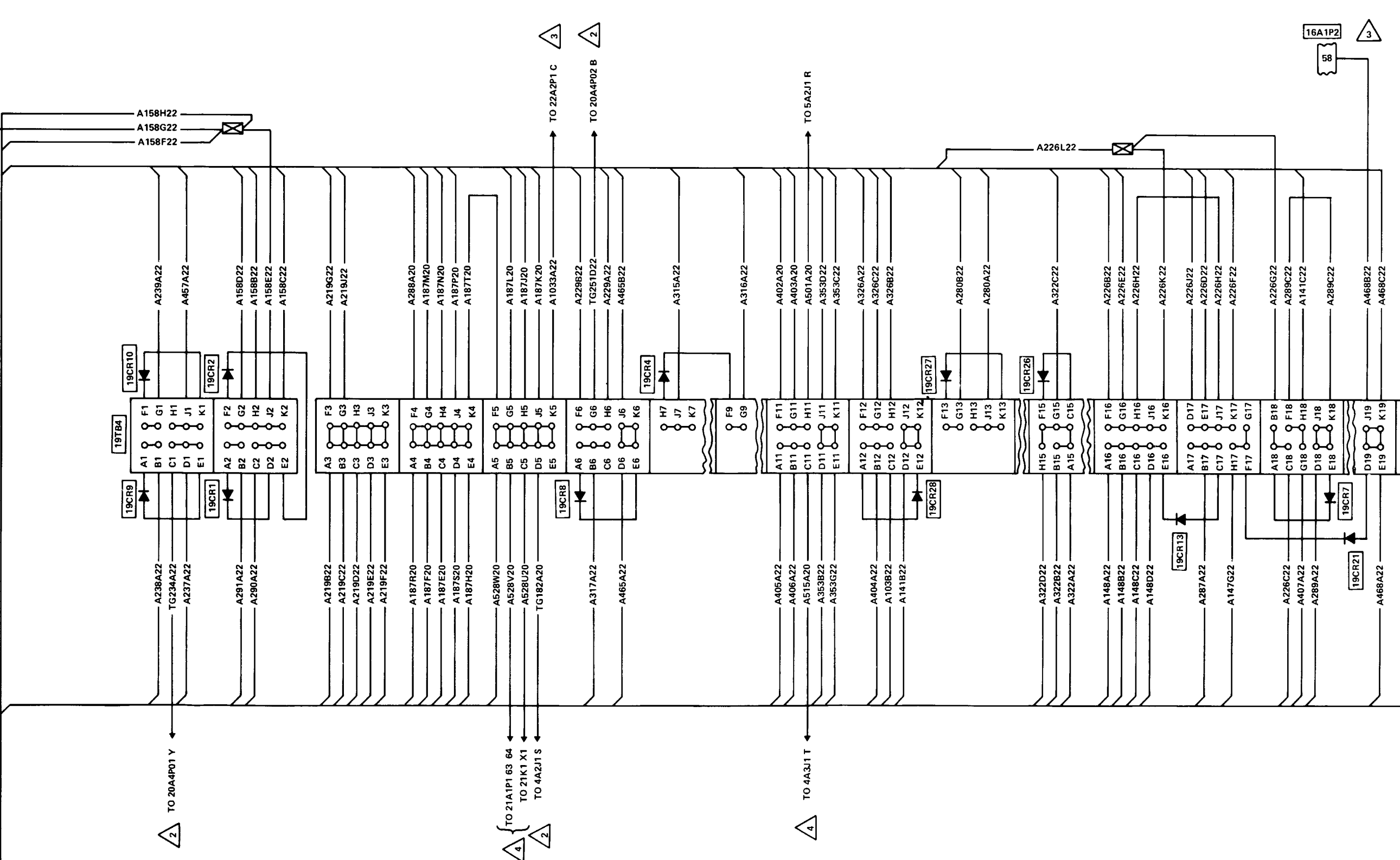
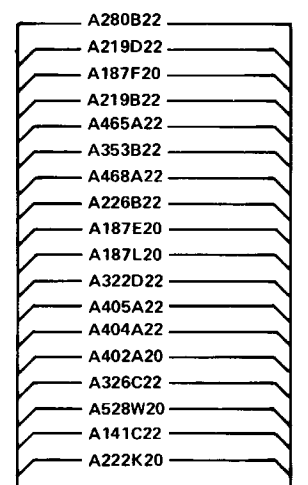

NOTE. Where Sheet 2 is referenced see FO-120  
 Where Sheet 3 is referenced see FO-121,  
 where Sheet 4 is referenced see FO-122,  
 where Sheet 5 is referenced see FO-123,  
 where Sheet 6 is referenced see FO-124  
 Where Sheet 7 is referenced see FO-125  
 Where Sheet 8 is referenced see FO-126  
 Where Sheet 9 is referenced see FO-127  
 Where Sheet 10 is referenced see FO-128  
 Where Sheet 11 is referenced see FO-129

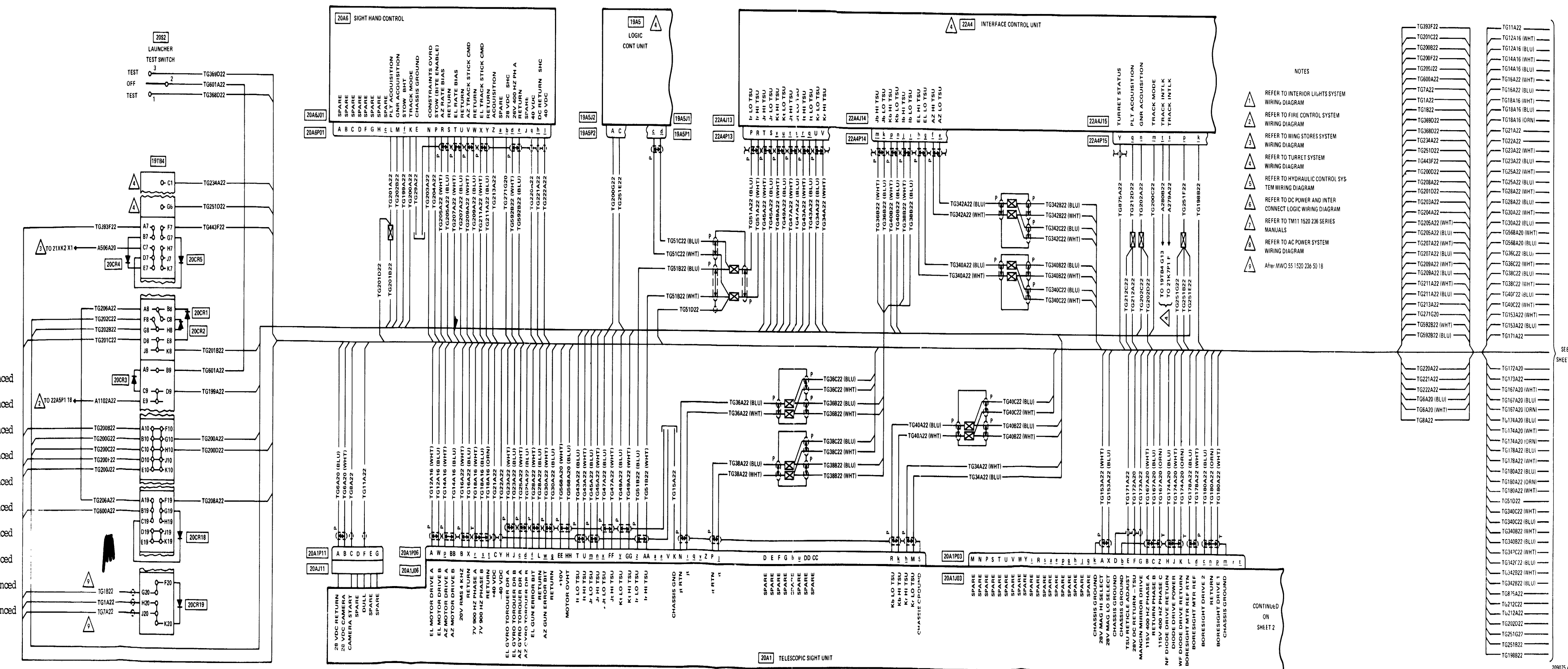

- NOTES
- △ REFER TO INTERIOR LIGHTS SYSTEM WIRING DIAGRAM
  - △ REFER TO FIRE CONTROL SYSTEM WIRING DIAGRAM
  - △ REFER TO WING STORES SYSTEM WIRING DIAGRAM
  - △ REFER TO TURRET SYSTEM WIRING DIAGRAM
  - △ REFER TO HYDRAULIC CONTROL SYSTEM WIRING DIAGRAM
  - △ REFER TO DC POWER AND INTERCONNECT LOGIC WIRING DIAGRAMS
  - △ REFER TO TM11 1520 236 SERIES MANUALS
  - △ REFER TO AC POWER SYSTEM WIRING DIAGRAM
- After MW2 55 1520 236 5/18

TG0102Z	TG0112Z
TG0112Z	TG0122Z
TG0122Z	TG0132Z
TG0132Z	TG0142Z
TG0142Z	TG0152Z
TG0152Z	TG0162Z
TG0162Z	TG0172Z
TG0172Z	TG0182Z
TG0182Z	TG0192Z
TG0192Z	TG0202Z
TG0202Z	TG0212Z
TG0212Z	TG0222Z
TG0222Z	TG0232Z
TG0232Z	TG0242Z
TG0242Z	TG0252Z
TG0252Z	TG0262Z
TG0262Z	TG0272Z
TG0272Z	TG0282Z
TG0282Z	TG0292Z
TG0292Z	TG0302Z
TG0302Z	TG0312Z
TG0312Z	TG0322Z
TG0322Z	TG0332Z
TG0332Z	TG0342Z
TG0342Z	TG0352Z
TG0352Z	TG0362Z
TG0362Z	TG0372Z
TG0372Z	TG0382Z
TG0382Z	TG0392Z
TG0392Z	TG0402Z
TG0402Z	TG0412Z
TG0412Z	TG0422Z
TG0422Z	TG0432Z
TG0432Z	TG0442Z
TG0442Z	TG0452Z
TG0452Z	TG0462Z
TG0462Z	TG0472Z
TG0472Z	TG0482Z
TG0482Z	TG0492Z
TG0492Z	TG0502Z
TG0502Z	TG0512Z
TG0512Z	TG0522Z
TG0522Z	TG0532Z
TG0532Z	TG0542Z
TG0542Z	TG0552Z
TG0552Z	TG0562Z
TG0562Z	TG0572Z
TG0572Z	TG0582Z
TG0582Z	TG0592Z
TG0592Z	TG0602Z
TG0602Z	TG0612Z
TG0612Z	TG0622Z
TG0622Z	TG0632Z
TG0632Z	TG0642Z
TG0642Z	TG0652Z
TG0652Z	TG0662Z
TG0662Z	TG0672Z
TG0672Z	TG0682Z
TG0682Z	TG0692Z
TG0692Z	TG0702Z
TG0702Z	TG0712Z
TG0712Z	TG0722Z
TG0722Z	TG0732Z
TG0732Z	TG0742Z
TG0742Z	TG0752Z
TG0752Z	TG0762Z
TG0762Z	TG0772Z
TG0772Z	TG0782Z
TG0782Z	TG0792Z
TG0792Z	TG0802Z
TG0802Z	TG0812Z
TG0812Z	TG0822Z
TG0822Z	TG0832Z
TG0832Z	TG0842Z
TG0842Z	TG0852Z
TG0852Z	TG0862Z
TG0862Z	TG0872Z
TG0872Z	TG0882Z
TG0882Z	TG0892Z
TG0892Z	TG0902Z
TG0902Z	TG0912Z
TG0912Z	TG0922Z
TG0922Z	TG0932Z
TG0932Z	TG0942Z
TG0942Z	TG0952Z
TG0952Z	TG0962Z
TG0962Z	TG0972Z
TG0972Z	TG0982Z
TG0982Z	TG0992Z
TG0992Z	TG1002Z

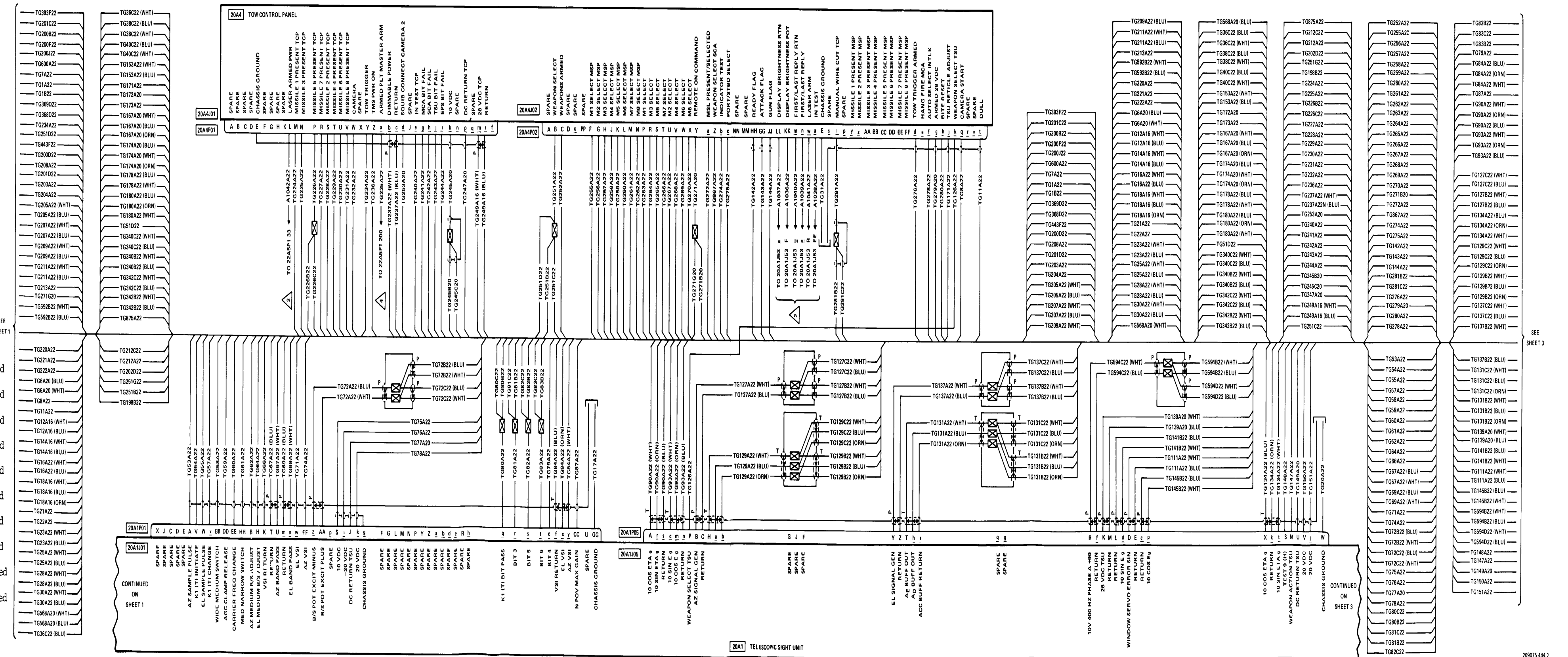

NOTE Where Sheet 1 is referenced see FO-119.  
 Where Sheet 3 is referenced see FO-121.  
 Where Sheet 4 is referenced see FO-122.  
 Where Sheet 5 is referenced see FO-123.  
 Where Sheet 6 is referenced see FO-124.  
 Where Sheet 7 is referenced see FO-125.  
 Where Sheet 8 is referenced see FO-126.  
 Where Sheet 9 is referenced see FO-127.  
 Where Sheet 10 is referenced see FO-128.  
 Where Sheet 11 is referenced see FO-129.

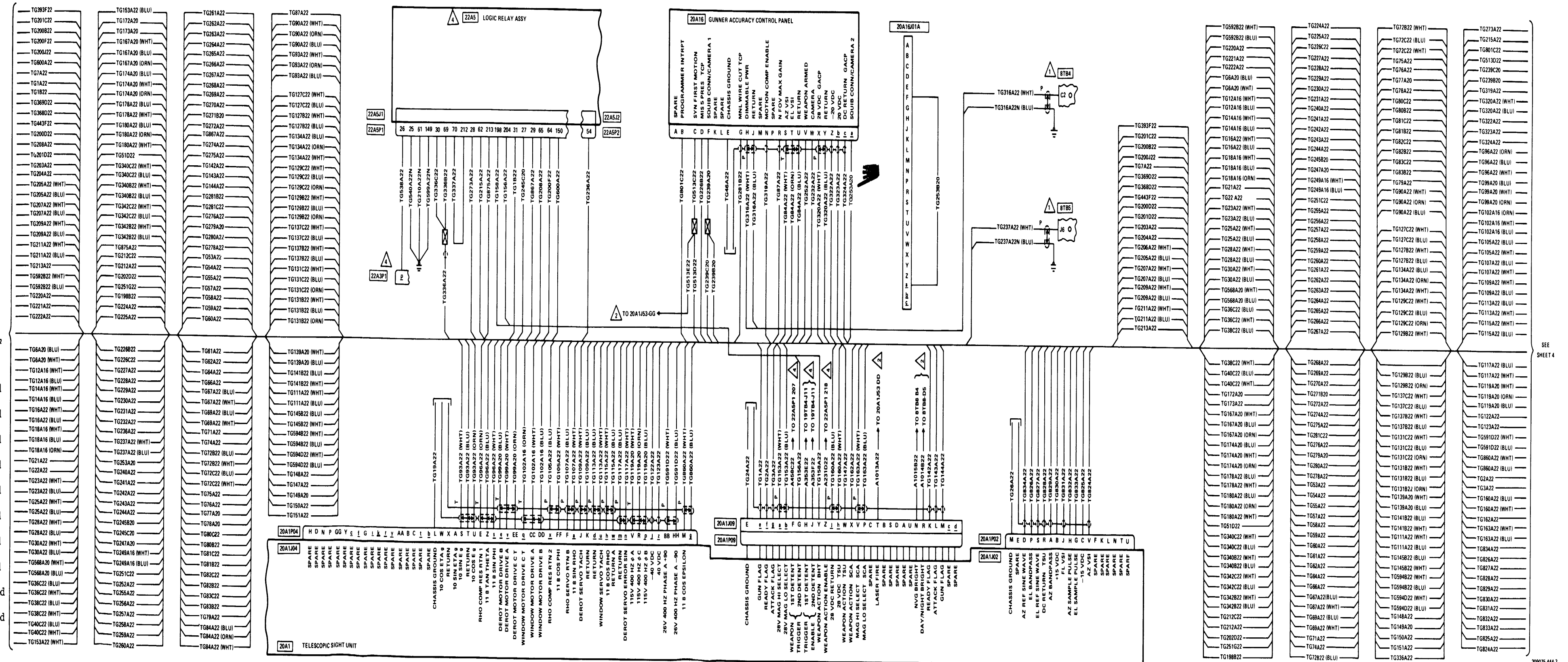

NOTE: Where Sheet 1 is referenced see FO-119, Where Sheet 2 is referenced see FO-120, Where Sheet 4 is referenced see FO-122, Where Sheet 5 is referenced see FO-123, Where Sheet 6 is referenced see FO-124, Where Sheet 7 is referenced see FO-125, Where Sheet 8 is referenced see FO-126, Where Sheet 9 is referenced see FO-127, Where Sheet 10 is referenced see FO-128, Where Sheet 11 is referenced see FO-129

SEE SHEET 2

SEE SHEET 4

20A1 TELESCOPIC SIGHT UNIT

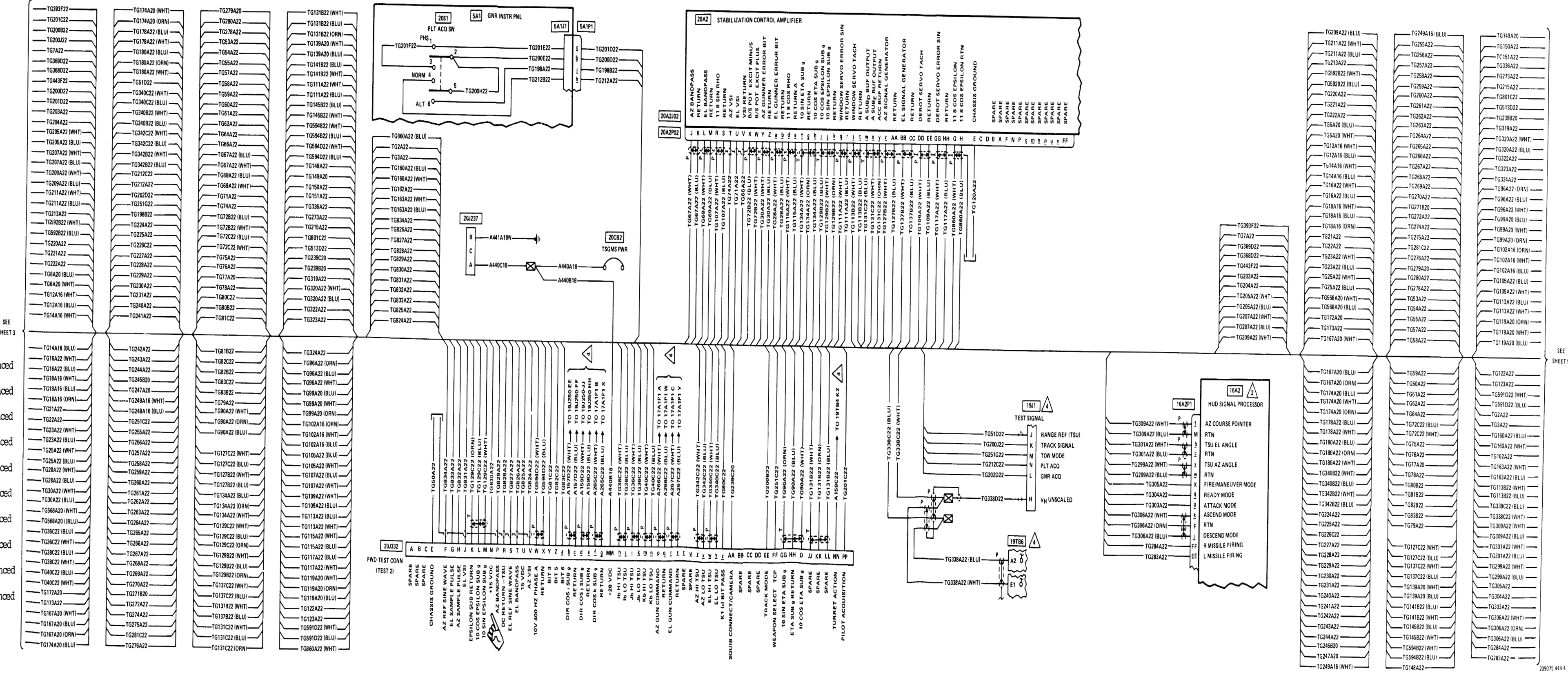

NOTE. Where Sheet 1 is referenced see PO-119, Where Sheet 2 is referenced see PO-120, Where Sheet 3 is referenced see PO-121, Where Sheet 5 is referenced see PO-123 Where Sheet 6 is referenced see PO-124 Where Sheet 7 is referenced see PO-125 Where Sheet 8 is referenced see PO-126 Where Sheet 9 is referenced see PO-127 Where Sheet 10 is referenced see PO-128 Where Sheet 11 is referenced see PO-129.



NOTE: Where Sheet 1 is referenced see FO-119  
 Where Sheet 2 is referenced see FO-120  
 Where Sheet 3 is referenced see FO-121  
 Where Sheet 4 is referenced see FO-122.  
 Where Sheet 6 is referenced see FO-124  
 Where Sheet 7 is referenced see FO-125.  
 Where Sheet 8 is referenced see FO-126.  
 Where Sheet 9 is referenced see FO-127  
 Where Sheet 10 is referenced see FO-128.  
 Where Sheet 11 is referenced see FO-129

SEE SHEET 4

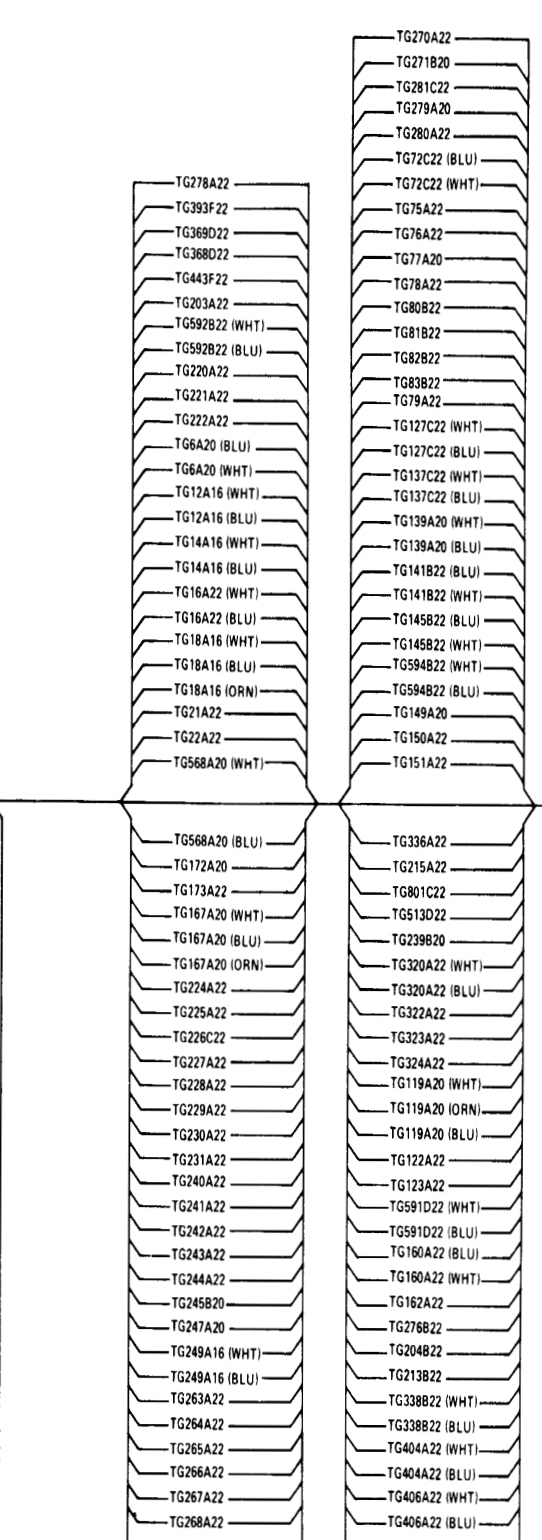
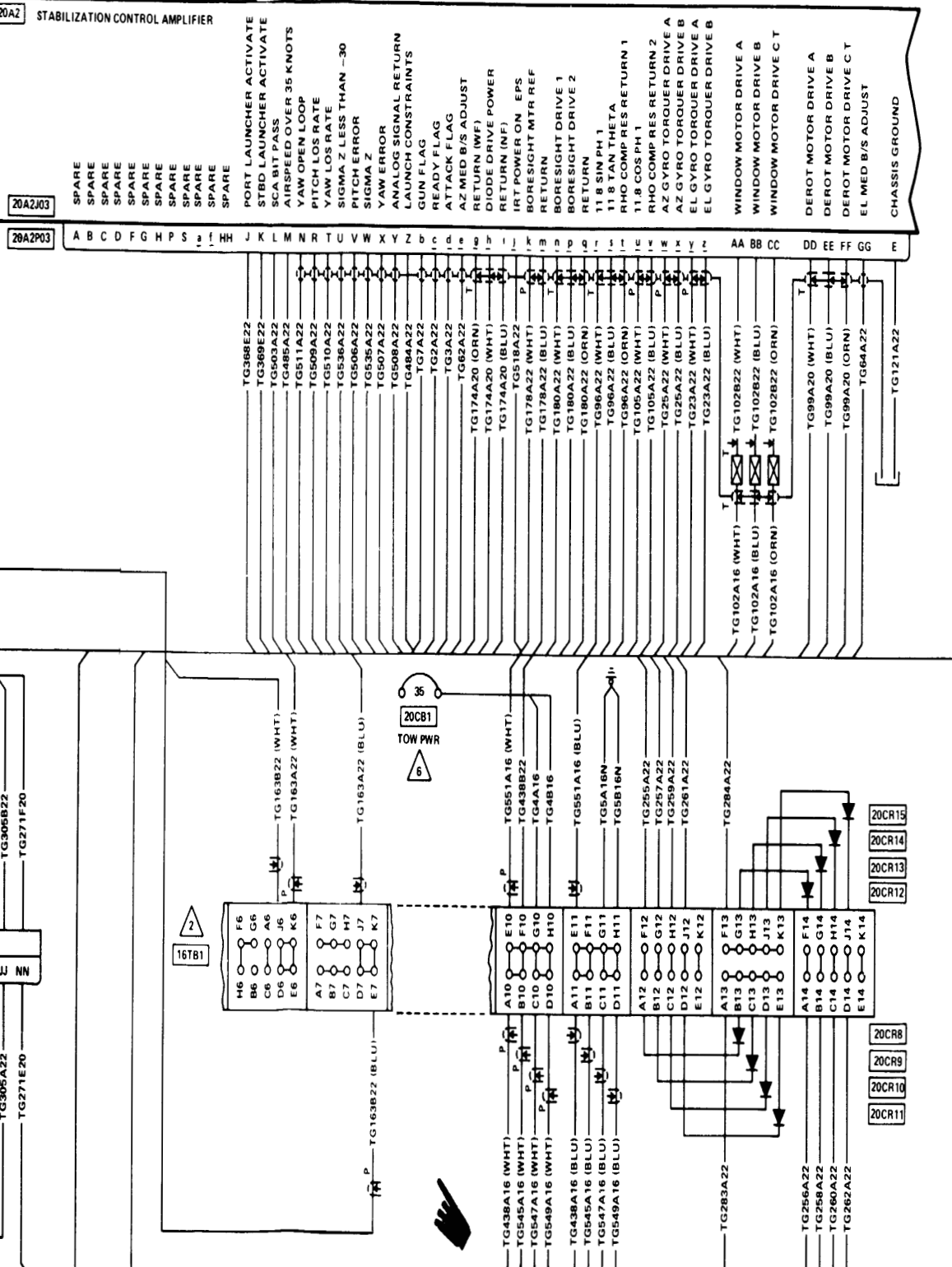
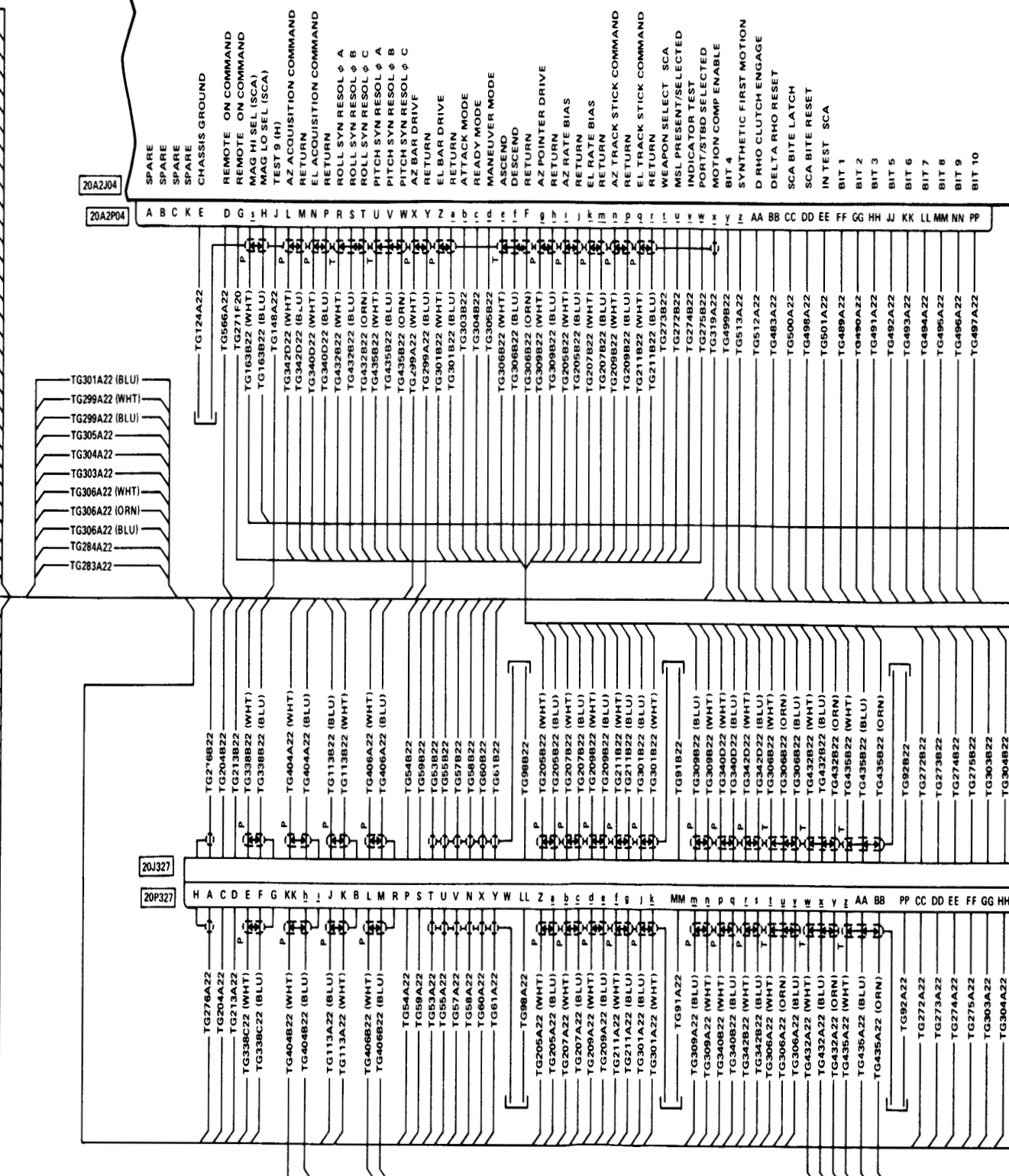
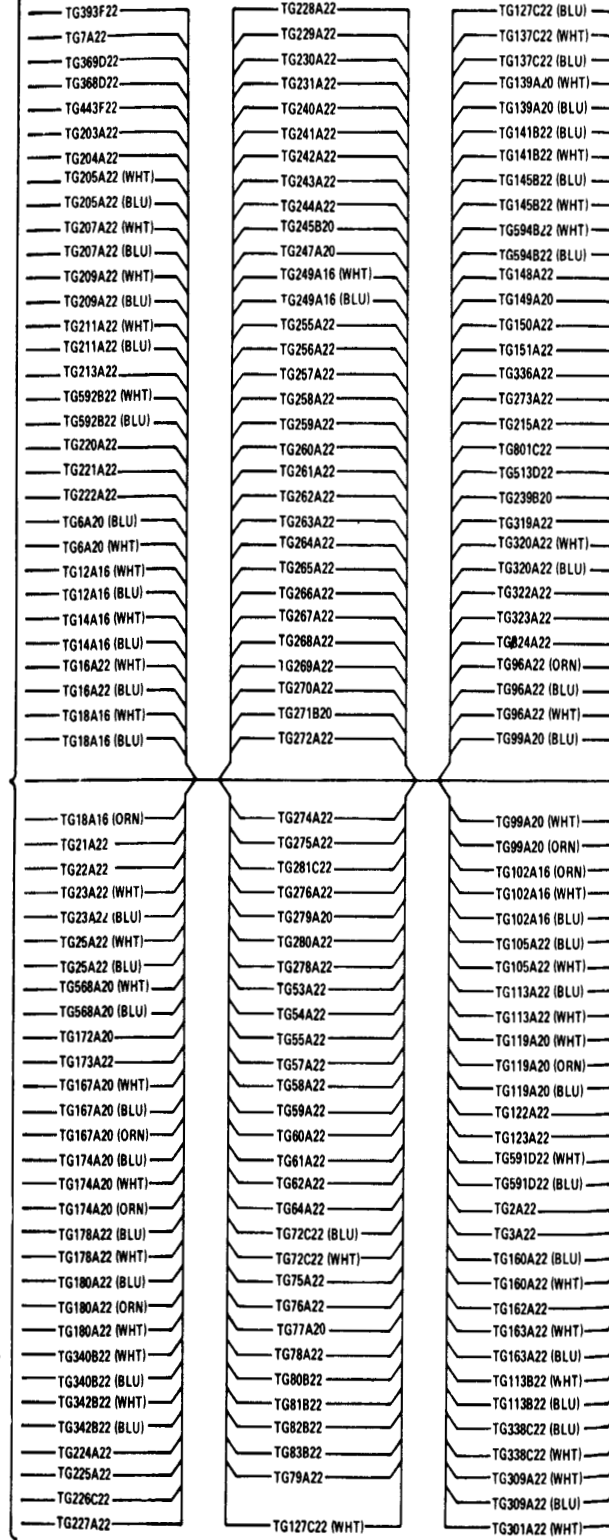

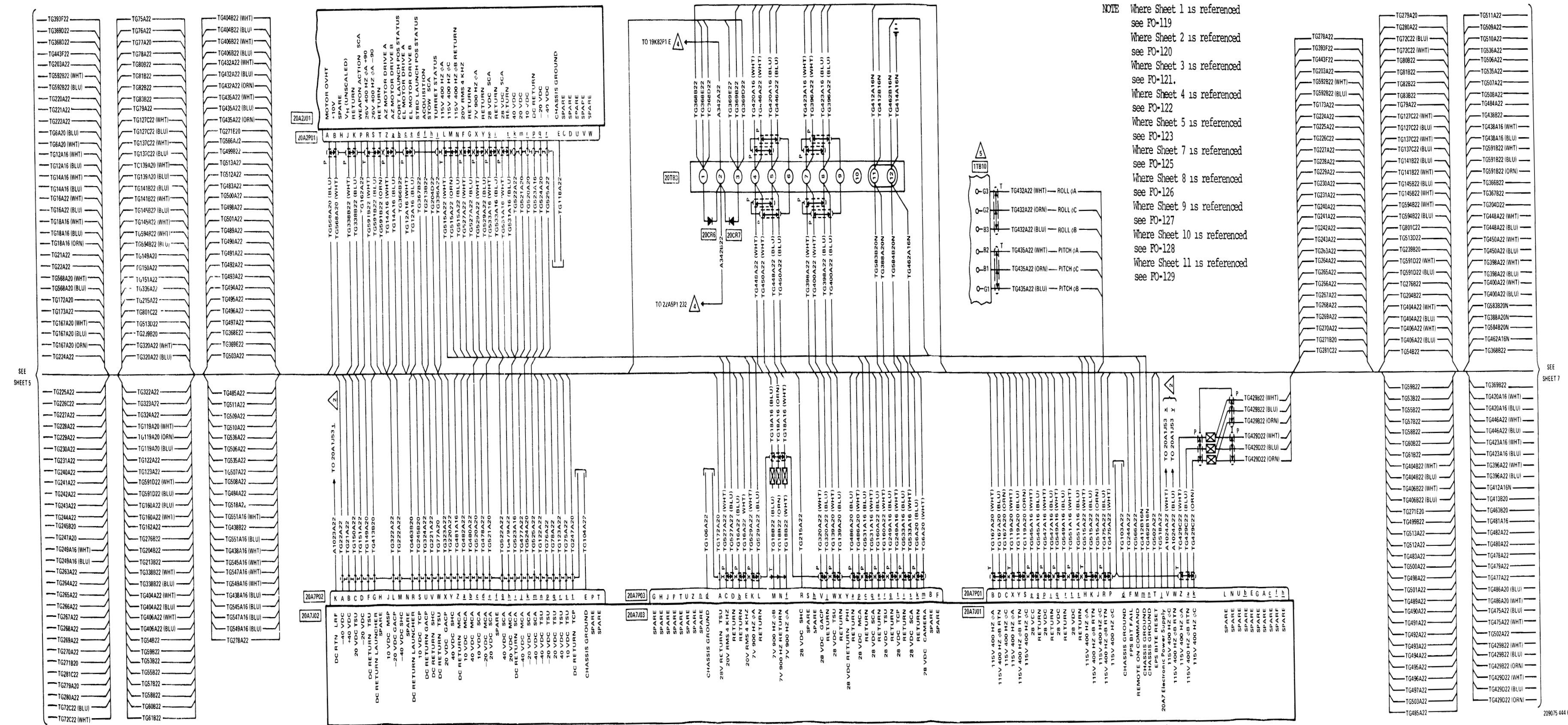

SEE SHEET 5

SEE SHEET 7



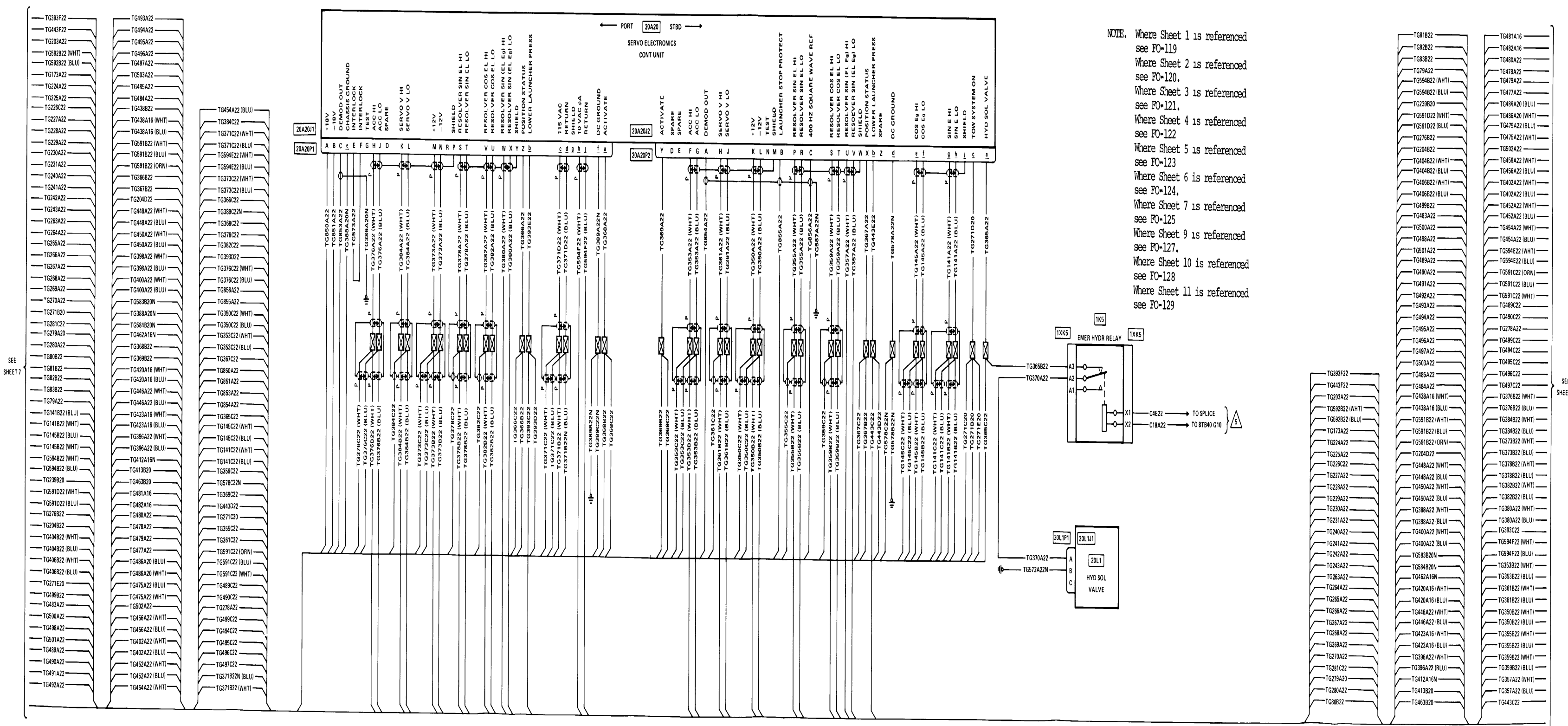

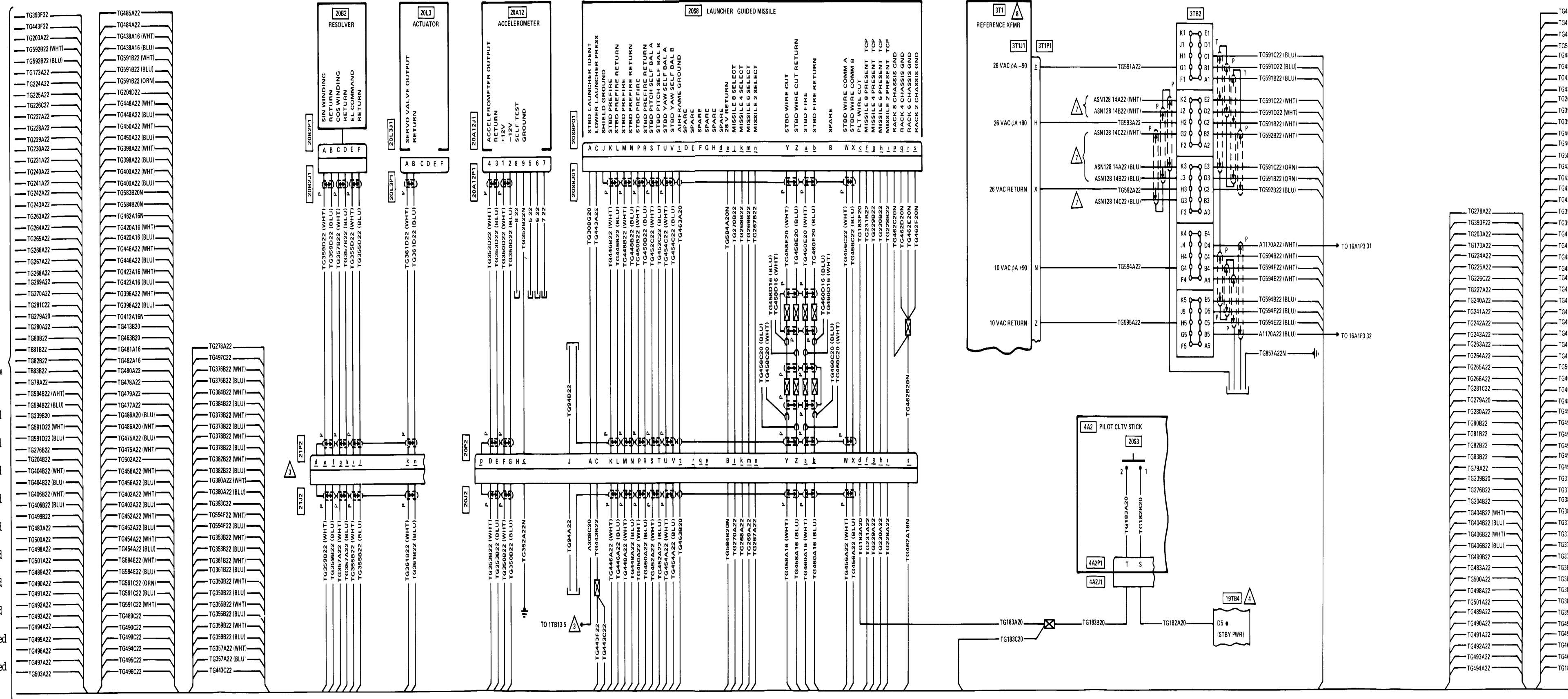

SEE SHEET B

NOTE: Where Sheet 1 is referenced see FO-119  
 Where Sheet 2 is referenced see FO-120  
 Where Sheet 3 is referenced see FO-121  
 Where Sheet 4 is referenced see FO-122.  
 Where Sheet 5 is referenced see FO-123  
 Where Sheet 6 is referenced see FO-124  
 Where Sheet 7 is referenced see FO-125  
 Where Sheet 8 is referenced see FO-126  
 Where Sheet 10 is referenced see FO-128  
 Where Sheet 11 is referenced see FO-129

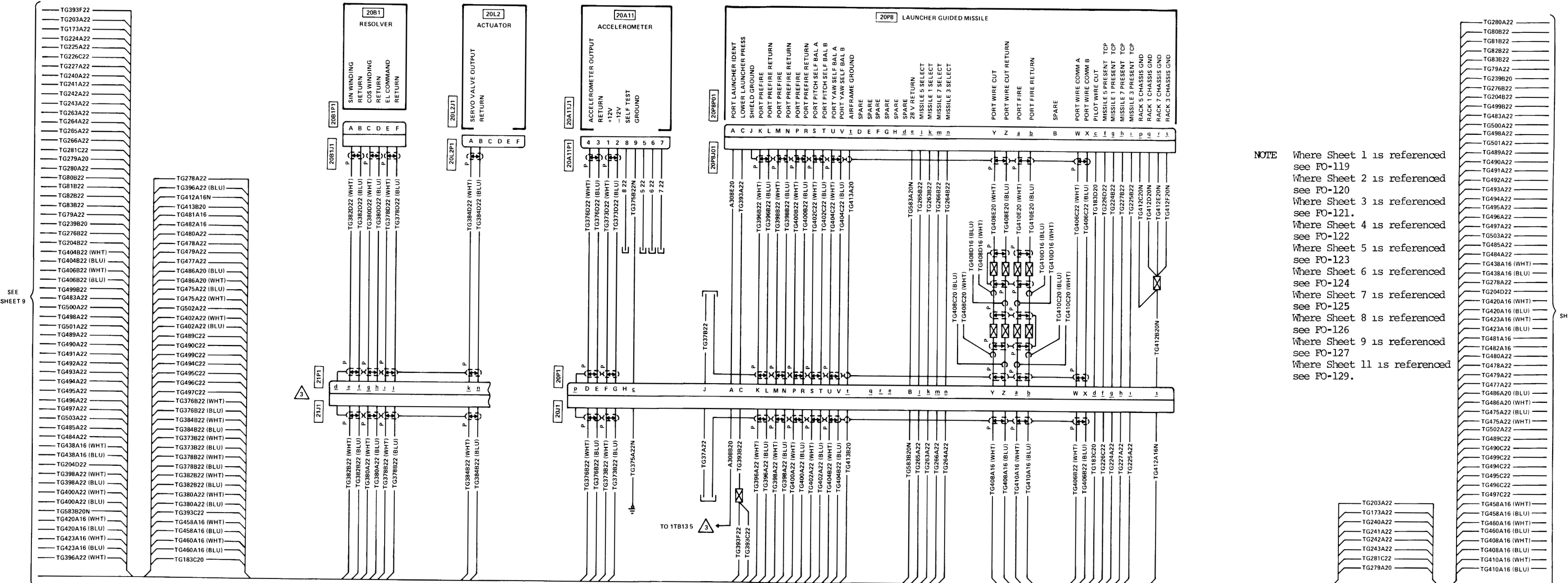

NOTE Where Sheet 1 is referenced see FO-119  
 Where Sheet 2 is referenced see FO-120  
 Where Sheet 3 is referenced see FO-121.  
 Where Sheet 4 is referenced see FO-122  
 Where Sheet 5 is referenced see FO-123  
 Where Sheet 6 is referenced see FO-124  
 Where Sheet 7 is referenced see FO-125  
 Where Sheet 8 is referenced see FO-126  
 Where Sheet 9 is referenced see FO-127  
 Where Sheet 11 is referenced see FO-129.

SEE SHEET 9

SEE SHEET 11







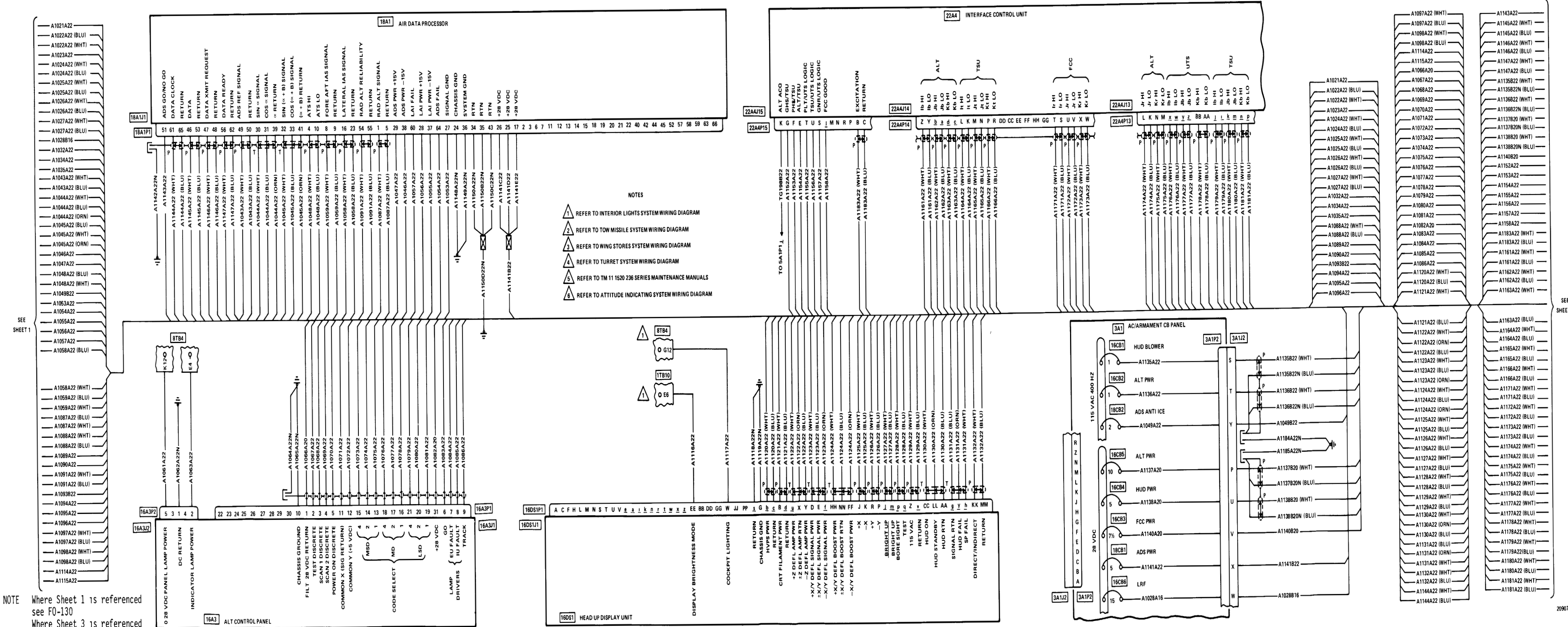

- NOTES**
- REFER TO INTERIOR LIGHTS SYSTEM WIRING DIAGRAM
  - REFER TO TOW MISSILE SYSTEM WIRING DIAGRAM
  - REFER TO WING STORES SYSTEM WIRING DIAGRAM
  - REFER TO TURRET SYSTEM WIRING DIAGRAM
  - REFER TO TM 11 1520 236 SERIES MAINTENANCE MANUALS
  - REFER TO ATTITUDE INDICATING SYSTEM WIRING DIAGRAM

NOTE: Where Sheet 1 is referenced see FO-130  
 Where Sheet 3 is referenced see FO-132  
 Where Sheet 4 is referenced see FO-133

SEE SHEET 3

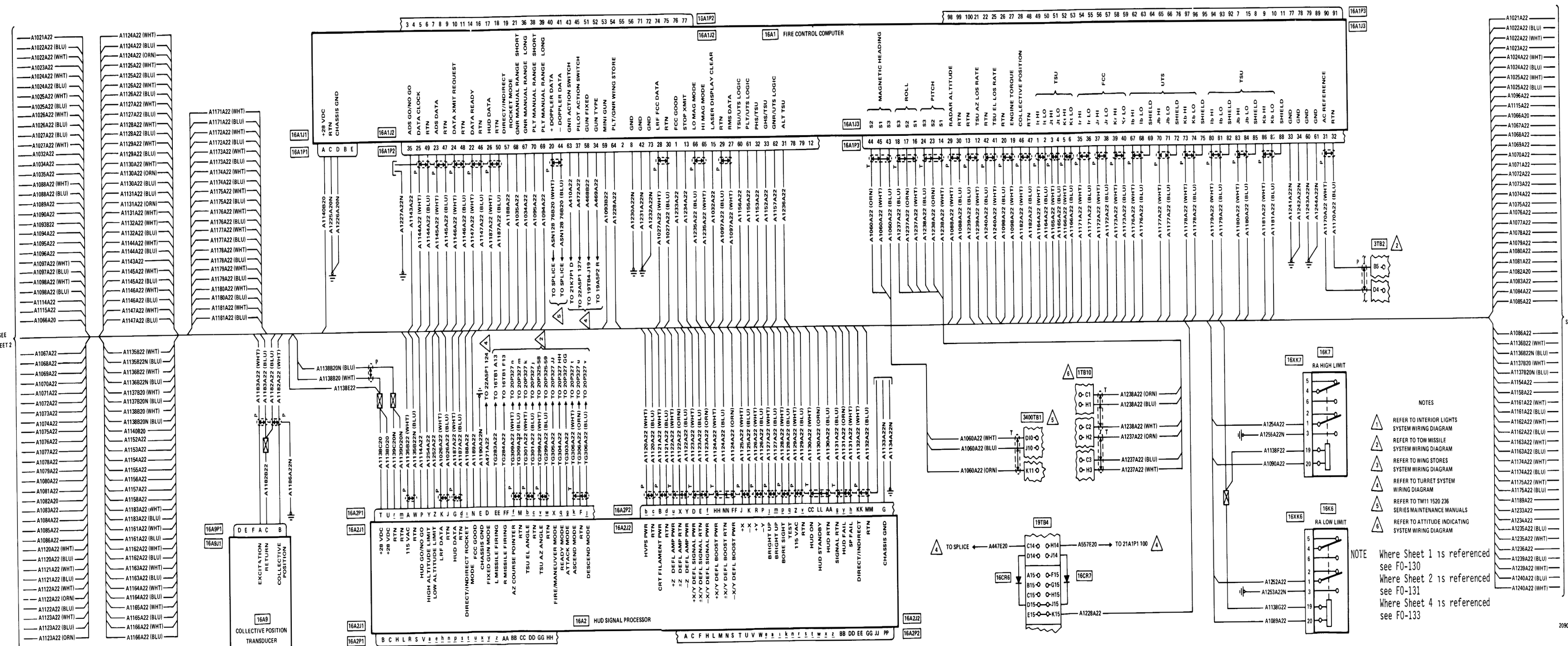

SEE SHEET 2

SEE SHEET 4

NOTES

- 1 REFER TO INTERIOR LIGHTS SYSTEM WIRING DIAGRAM
- 2 REFER TO TOW MISSILE SYSTEM WIRING DIAGRAM
- 3 REFER TO WING STORES SYSTEM WIRING DIAGRAM
- 4 REFER TO TURRET SYSTEM WIRING DIAGRAM
- 5 REFER TO TM11 1520 236 SERIES MAINTENANCE MANUALS
- 6 REFER TO ATTITUDE INDICATING SYSTEM WIRING DIAGRAM

NOTE Where Sheet 1 is referenced see FO-130  
Where Sheet 2 is referenced see FO-131  
Where Sheet 4 is referenced see FO-133

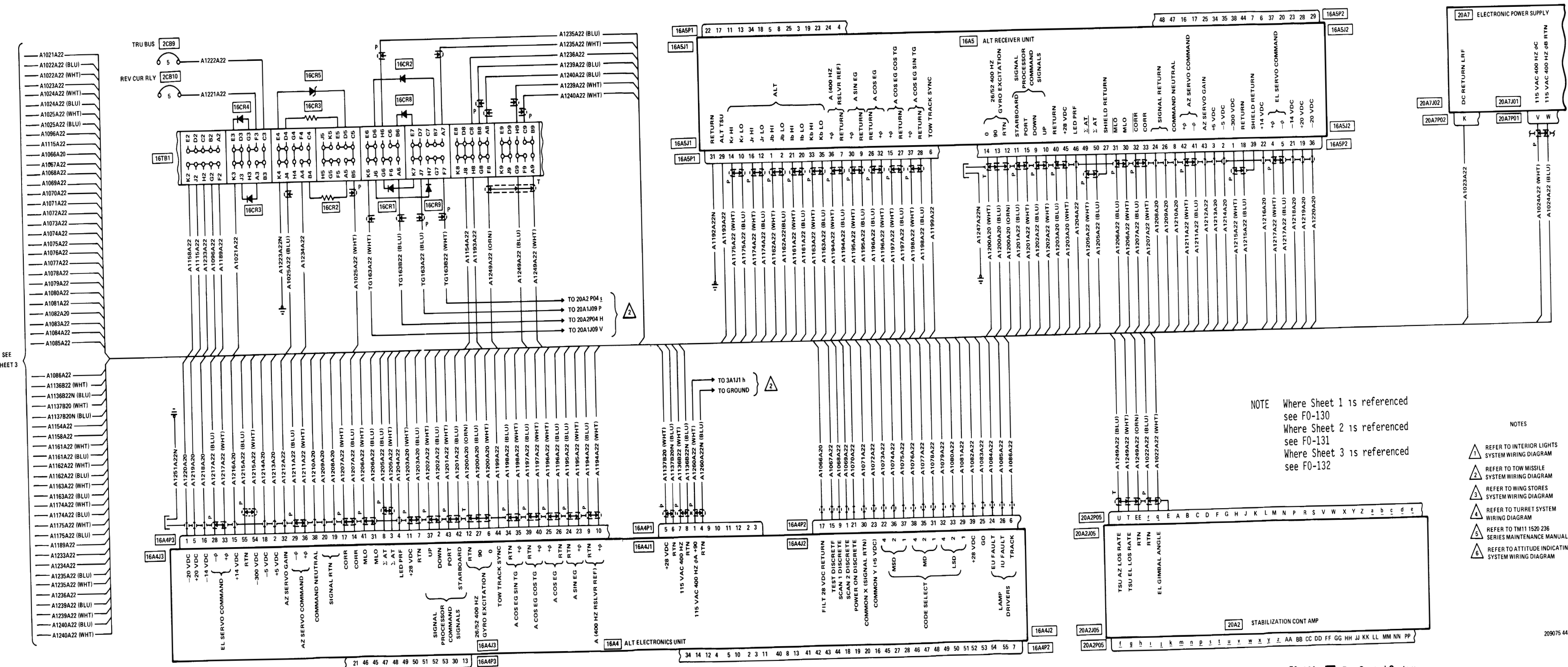

SEE SHEET 3

NOTE: Where Sheet 1 is referenced see F0-130  
 Where Sheet 2 is referenced see F0-131  
 Where Sheet 3 is referenced see F0-132

- NOTES
- ⚠ REFER TO INTERIOR LIGHTS SYSTEM WIRING DIAGRAM
  - ⚠ REFER TO TOW MISSILE SYSTEM WIRING DIAGRAM
  - ⚠ REFER TO WING STORES SYSTEM WIRING DIAGRAM
  - ⚠ REFER TO TURRET SYSTEM WIRING DIAGRAM
  - ⚠ REFER TO TM11 1520 236 SERIES MAINTENANCE MANUALS
  - ⚠ REFER TO ATTITUDE INDICATING SYSTEM WIRING DIAGRAM

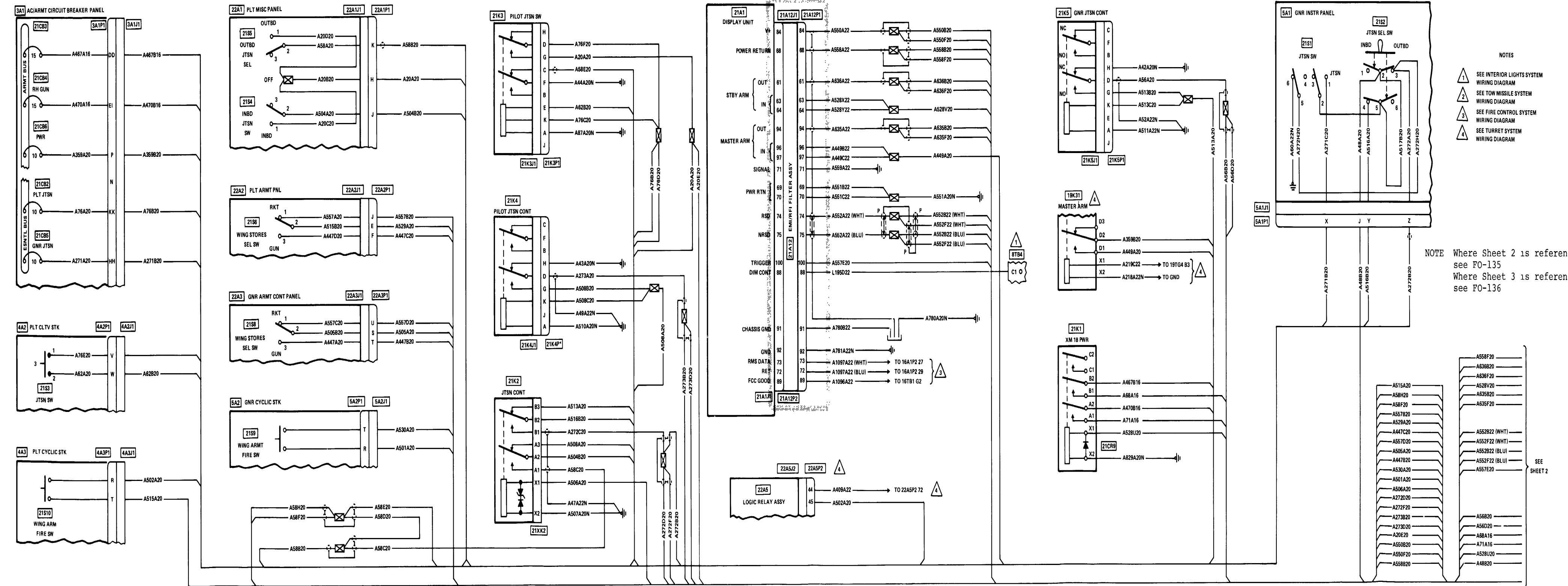

- NOTES
- 1 SEE INTERIOR LIGHTS SYSTEM WIRING DIAGRAM
  - 2 SEE TOW MISSILE SYSTEM WIRING DIAGRAM
  - 3 SEE FIRE CONTROL SYSTEM WIRING DIAGRAM
  - 4 SEE TURRET SYSTEM WIRING DIAGRAM

NOTE Where Sheet 2 is referenced see FO-135  
Where Sheet 3 is referenced see FO-136

SEE SHEET 2

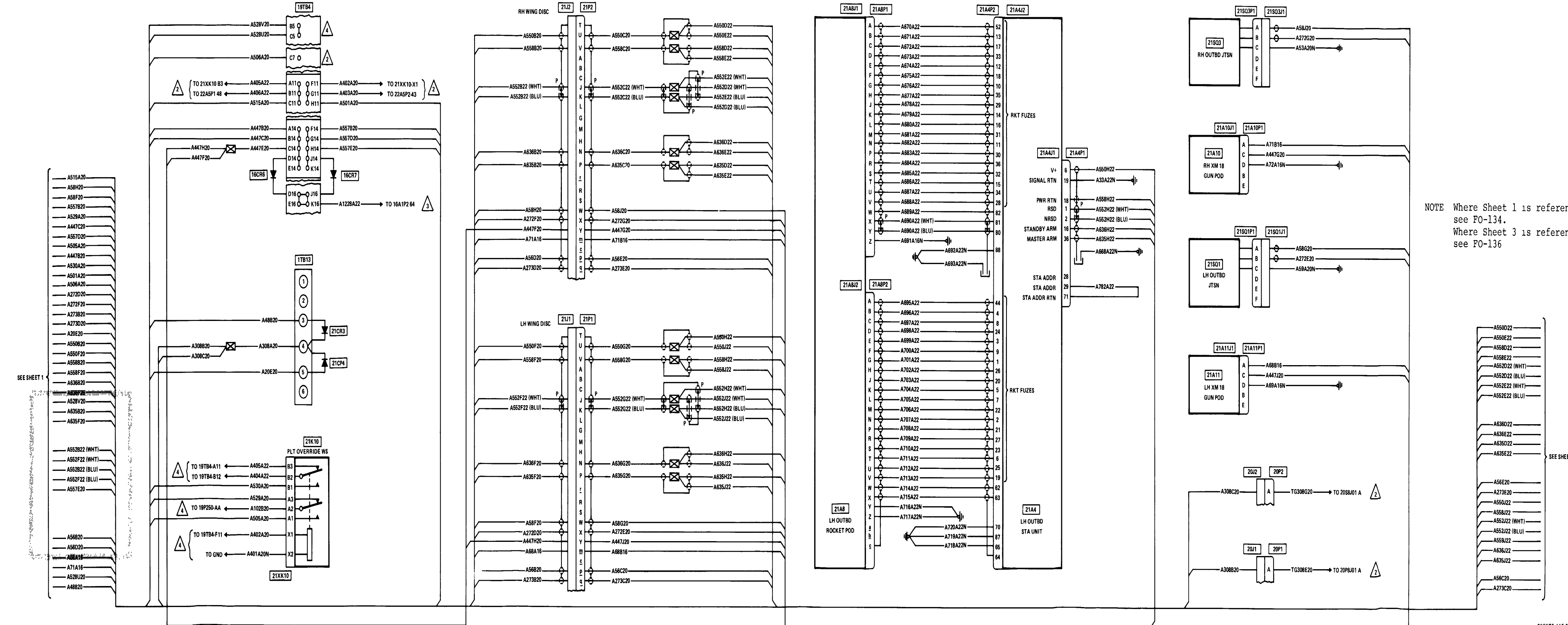

NOTE Where Sheet 1 is referenced see FO-134.  
Where Sheet 3 is referenced see FO-136

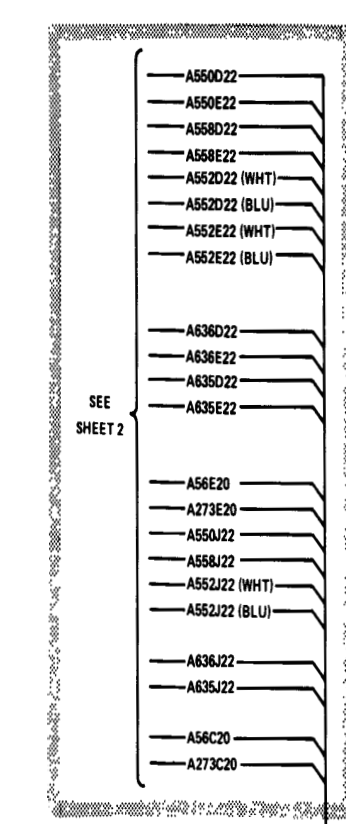
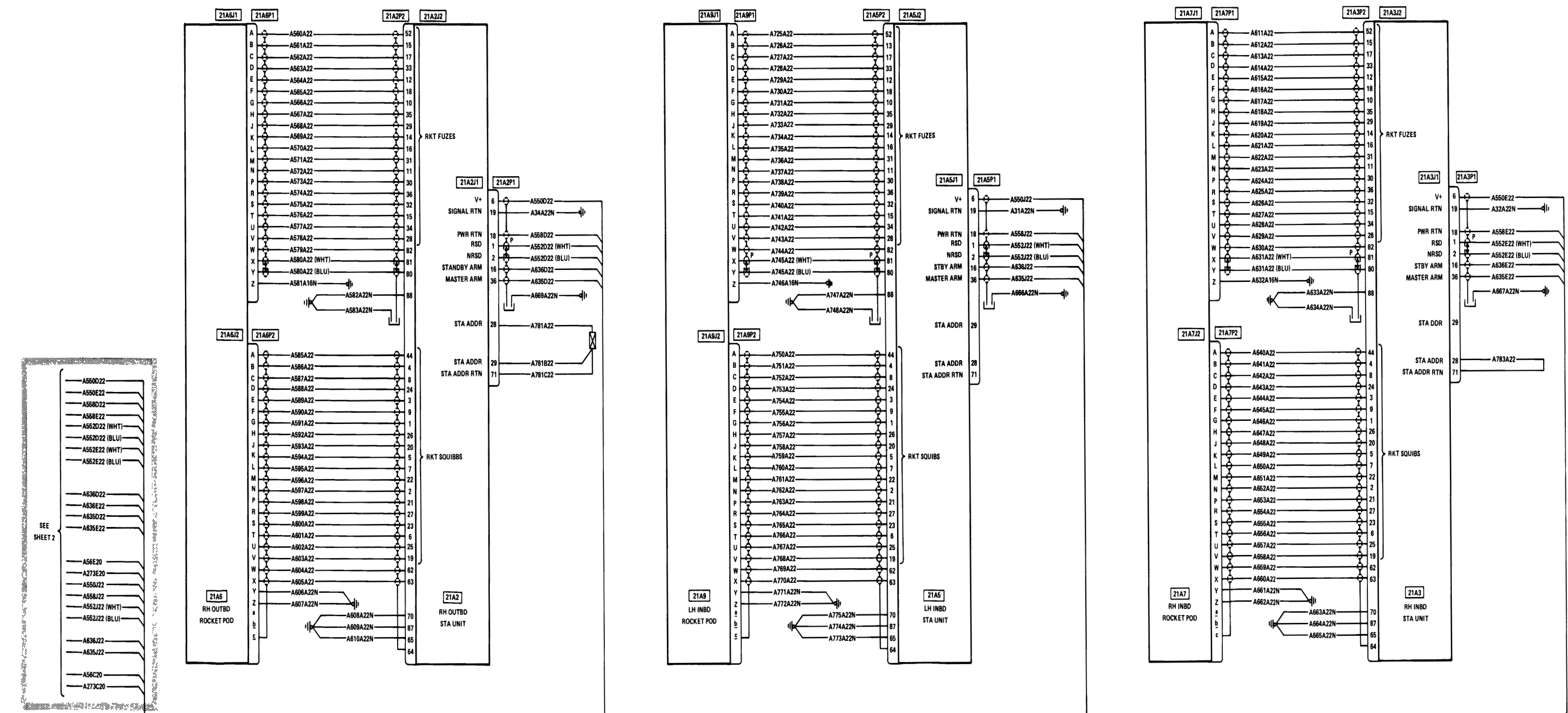

NOTE Where Sheet 1 is referenced see FO-134  
Where Sheet 2 is referenced see FO-135

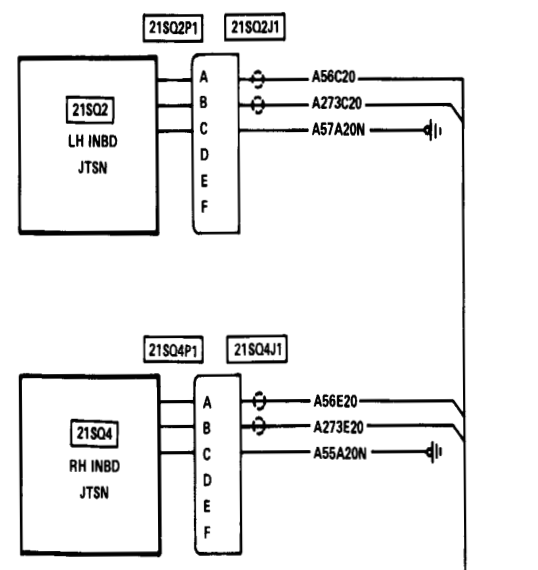

NOTE Where Sheet 2 is referenced see F0-138  
 Where Sheet 3 is referenced see F0-139  
 Where Sheet 4 is referenced see F0-140  
 Where Sheet 5 is referenced see F0-141  
 Where Sheet 6 is referenced see F0-142

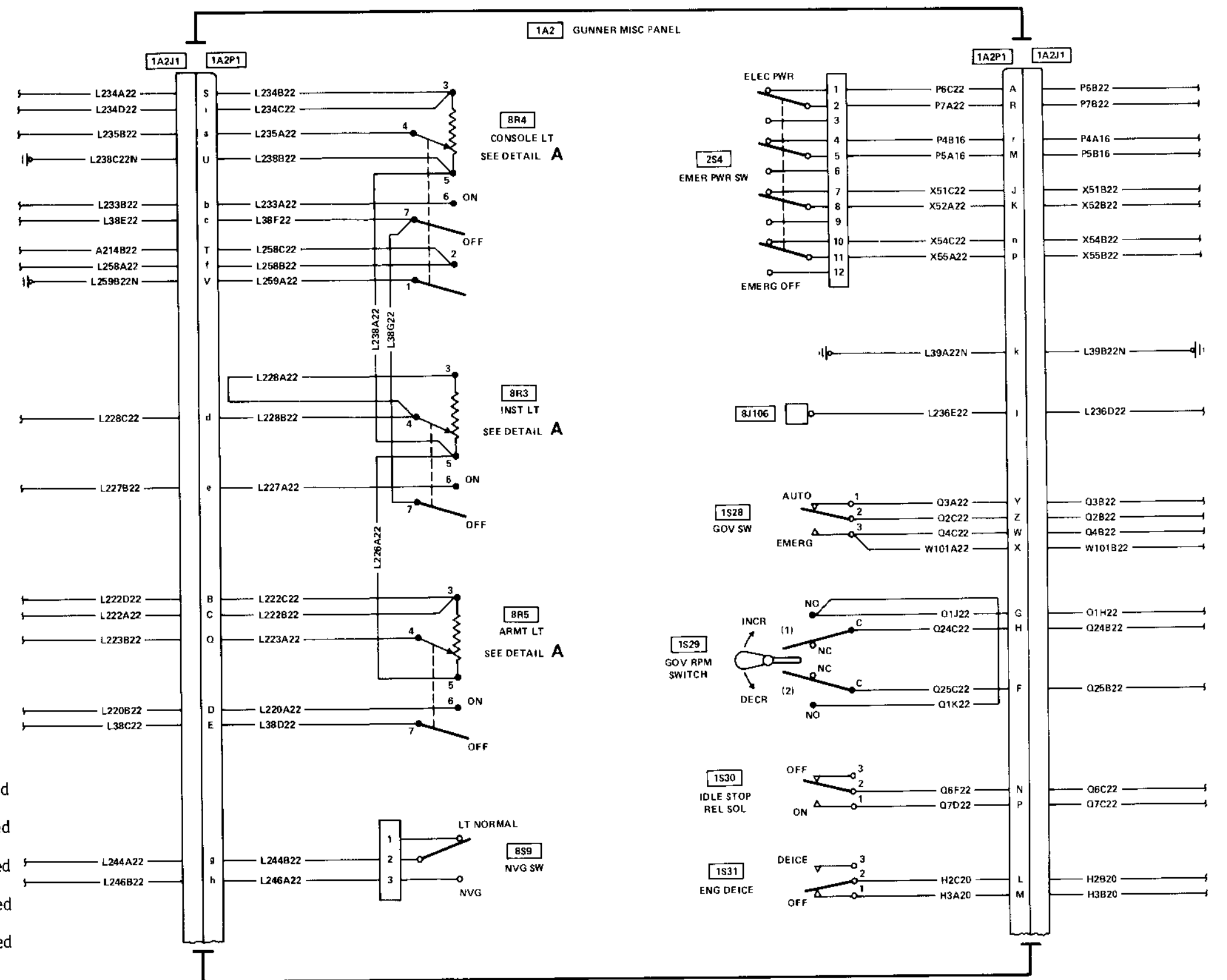

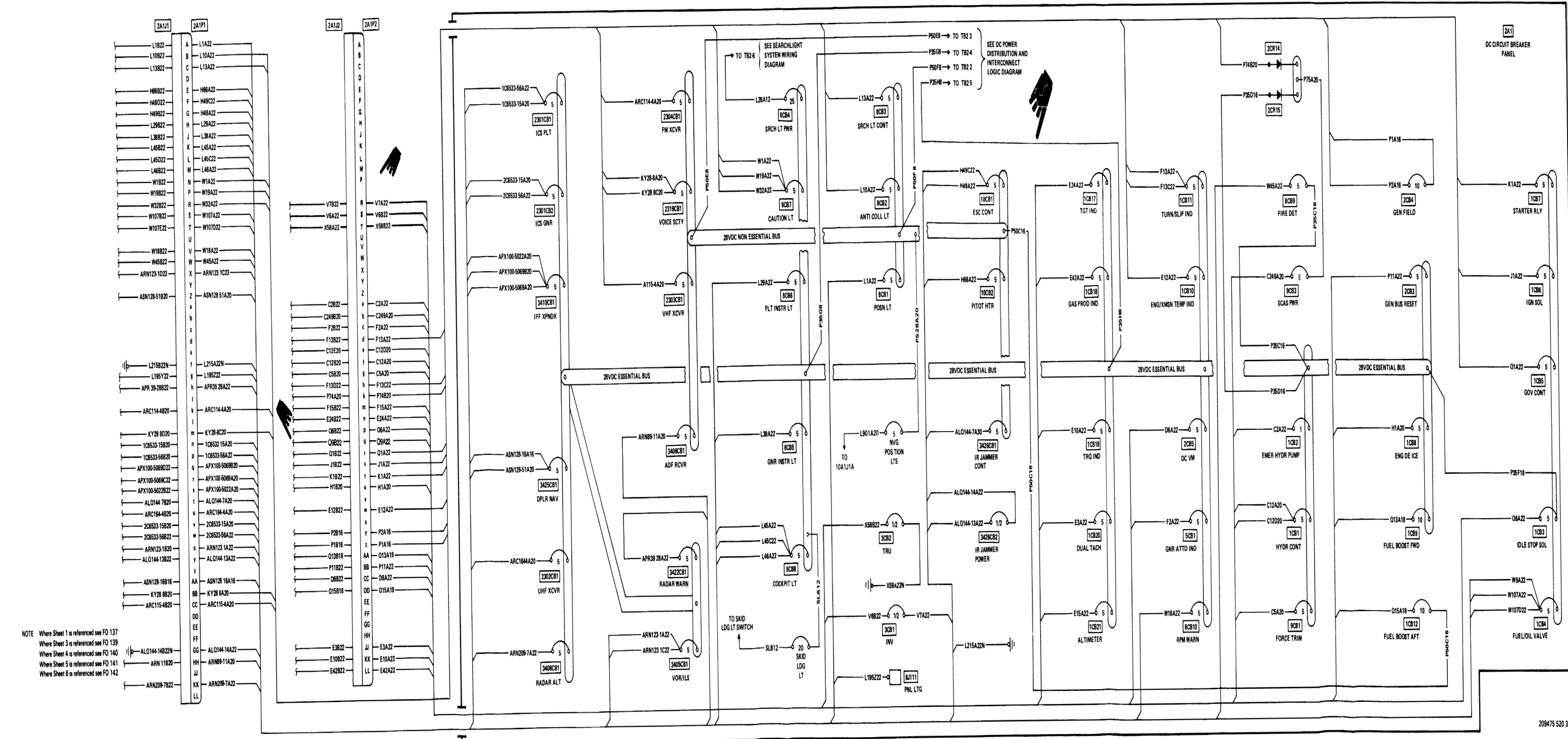



NOTE Where Sheet 1 is referenced see F0-137  
 Where Sheet 2 is referenced see F0-138  
 Where Sheet 4 is referenced see F0-140  
 Where Sheet 5 is referenced see F0-141  
 Where Sheet 6 is referenced see F0-142

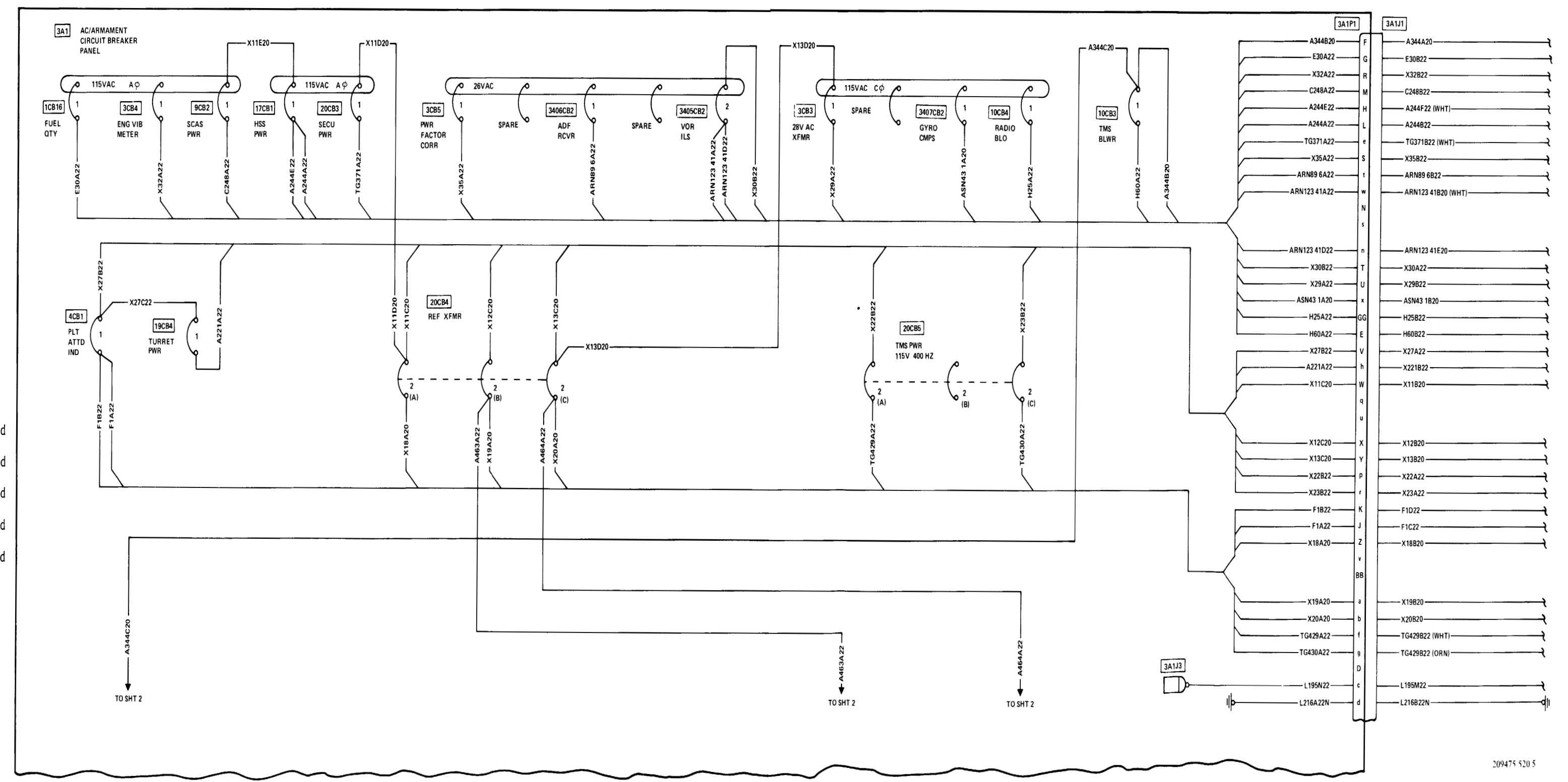

NOTE Where Sheet 1 is referenced see FO-137  
 Where Sheet 2 is referenced see FO-138  
 Where Sheet 3 is referenced see FO-139  
 Where Sheet 5 is referenced see FO-141  
 Where Sheet 6 is referenced see FO-142

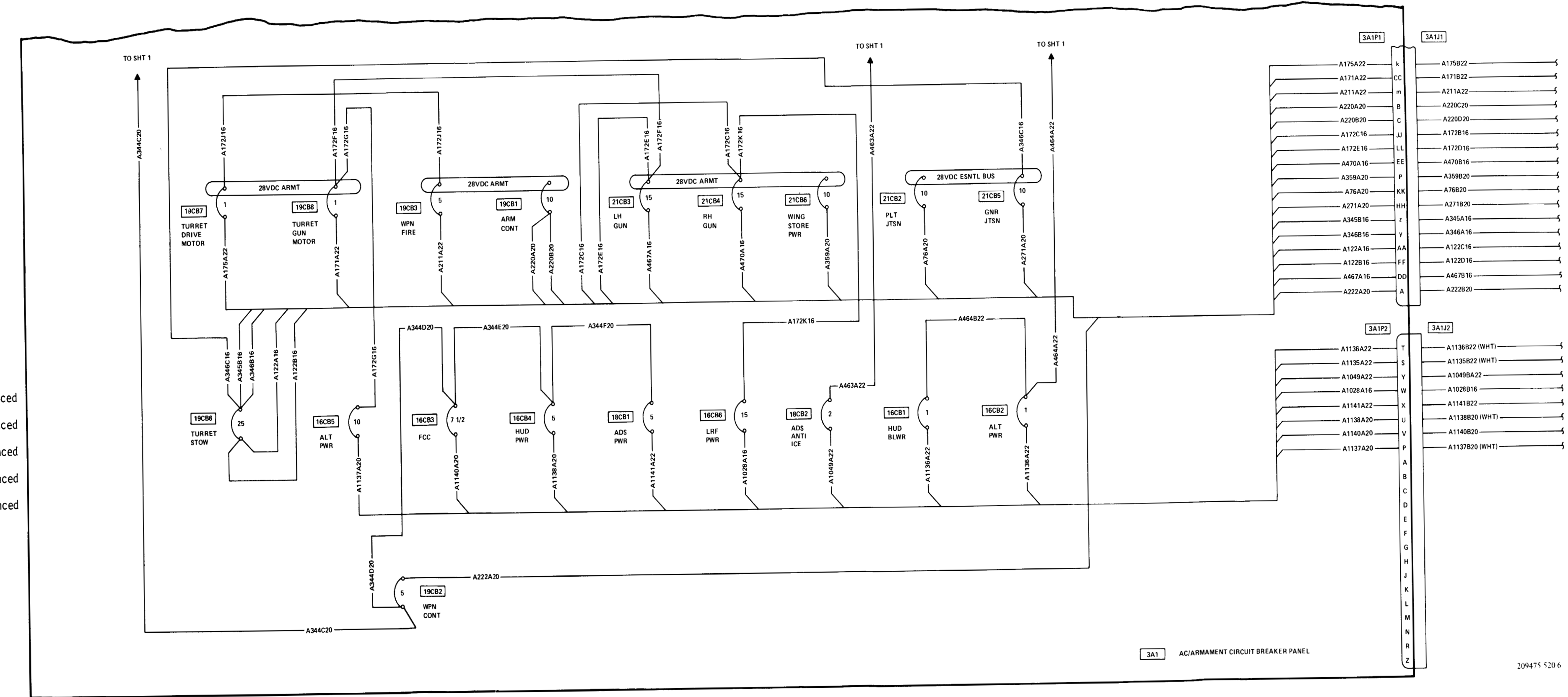

NOTE Where Sheet 1 is referenced see F0-137  
 Where Sheet 2 is referenced see F0-138  
 Where Sheet 3 is referenced see F0-139  
 Where Sheet 4 is referenced see F0-140  
 Where Sheet 6 is referenced see F0-142

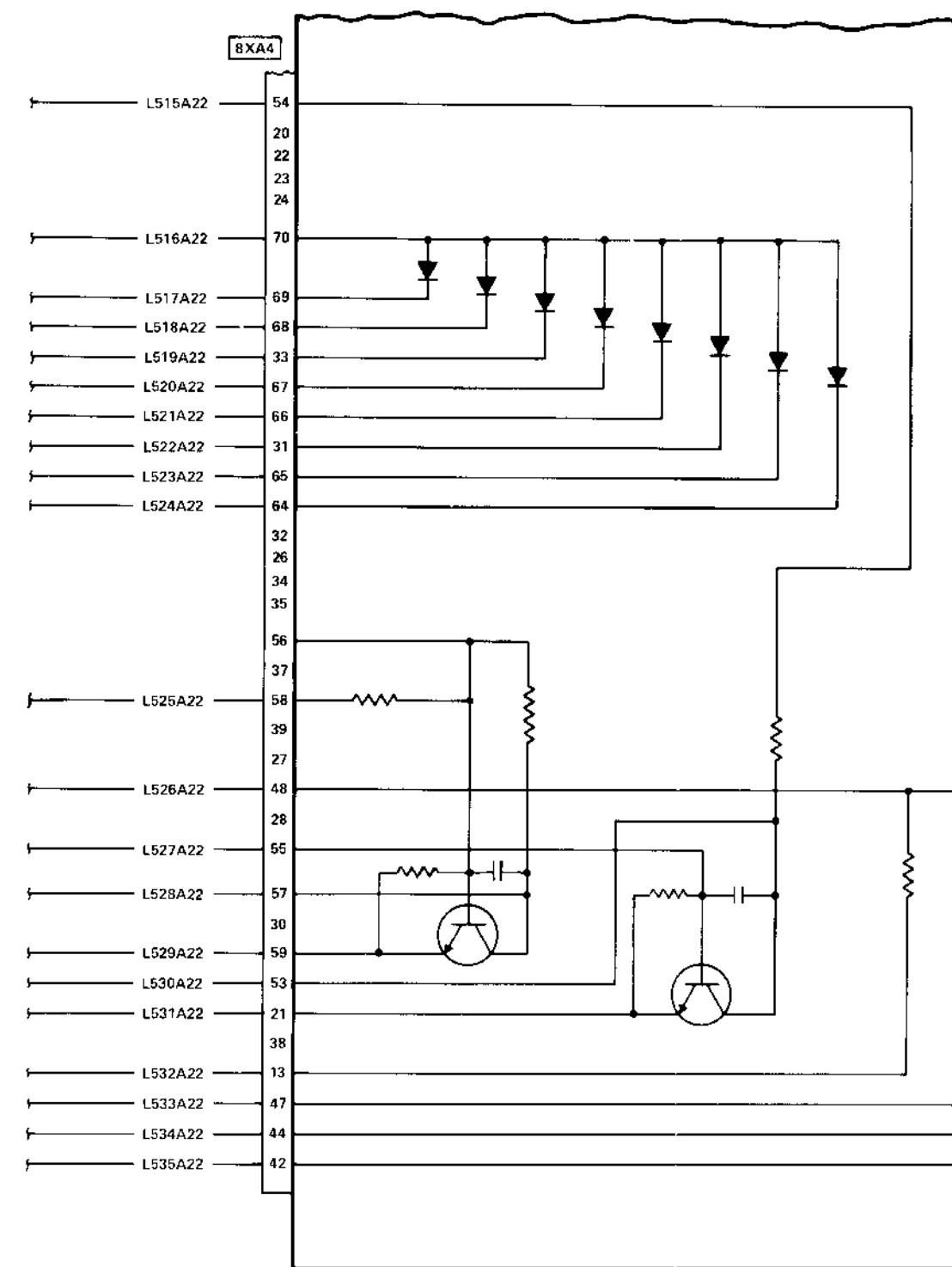
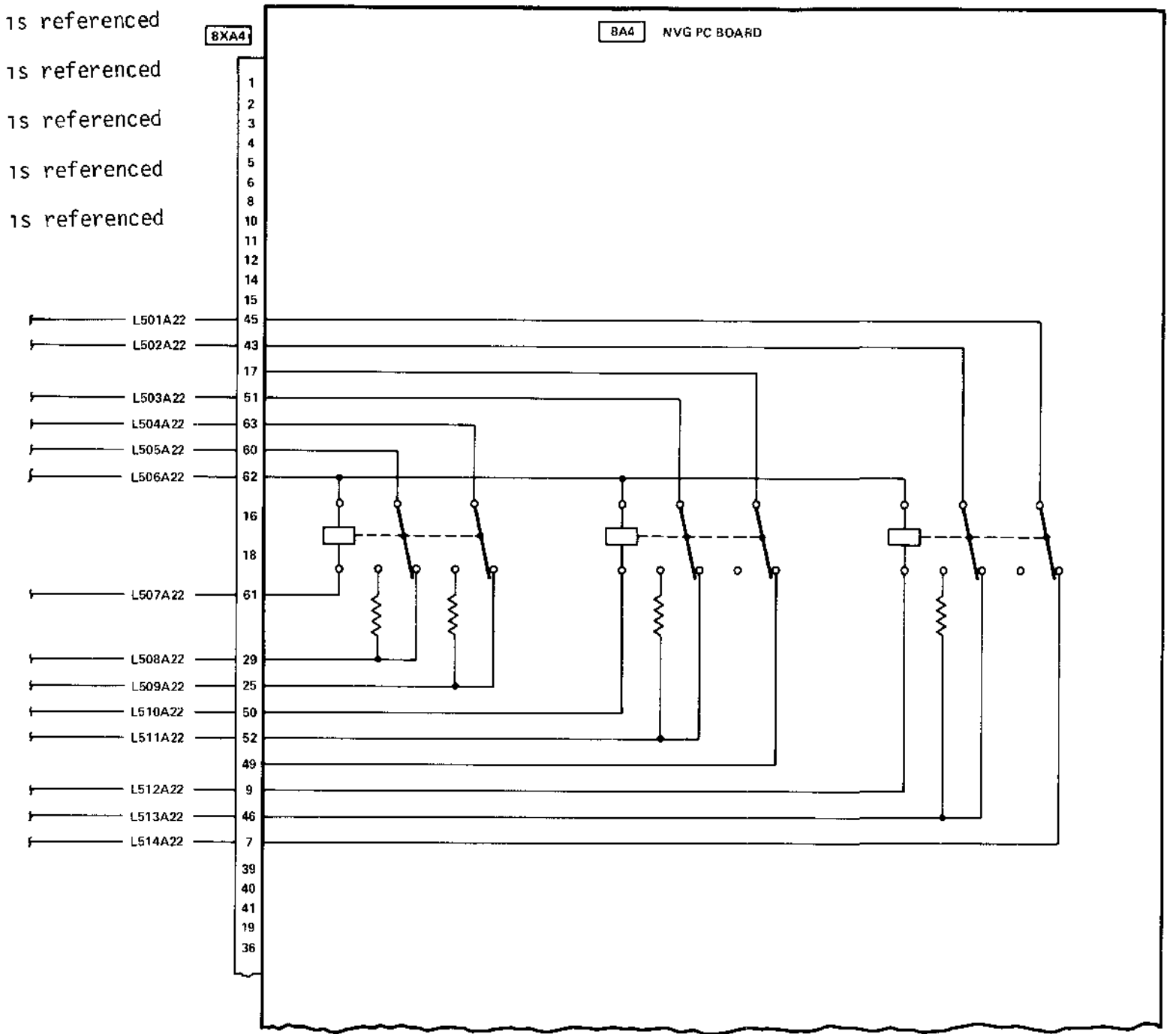

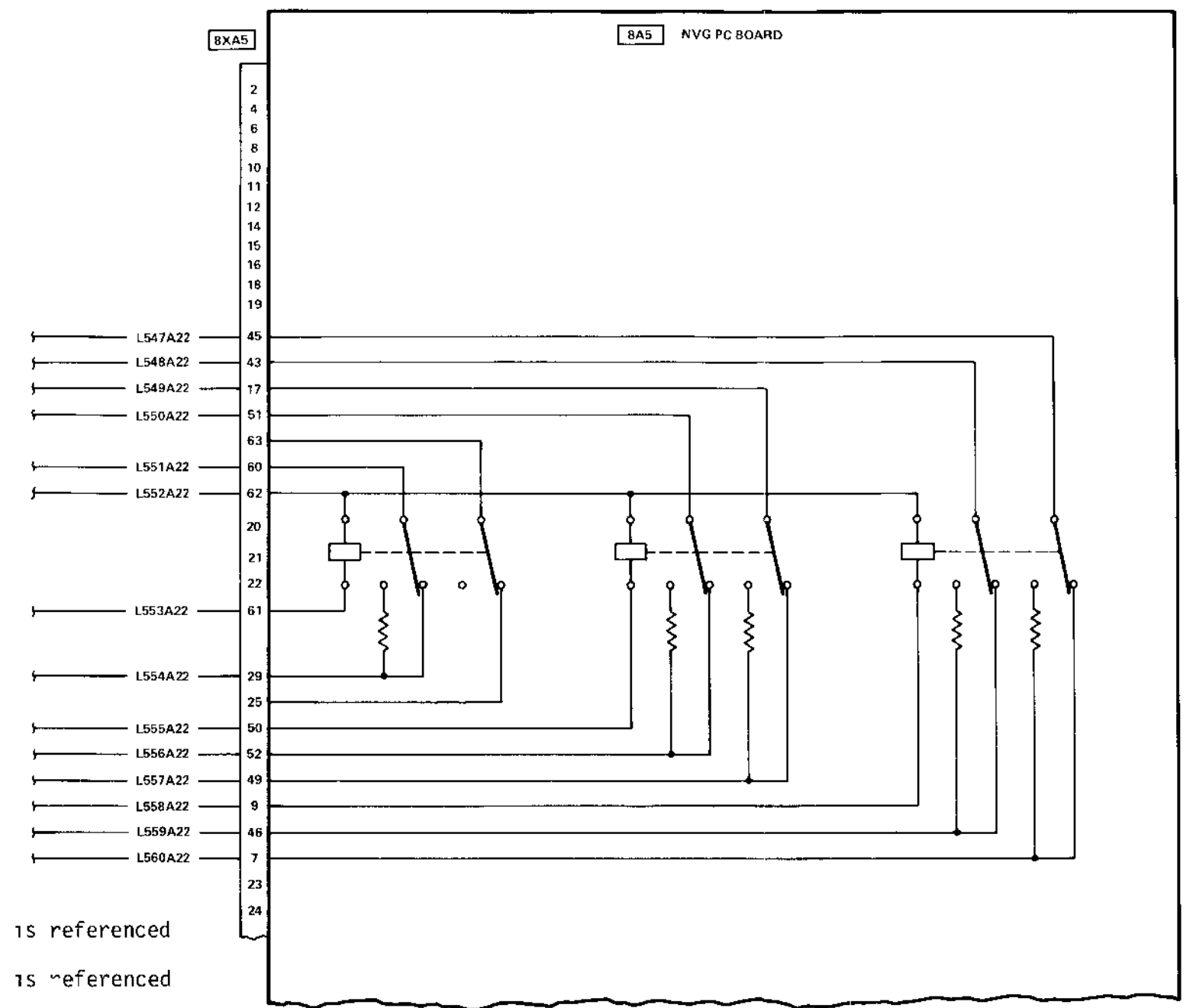

NOTE Where Sheet 1 is referenced see FO-137  
 Where Sheet 2 is referenced see FO-138  
 Where Sheet 3 is referenced see FO-139  
 Where Sheet 4 is referenced see FO-140  
 Where Sheet 5 is referenced see FO-141

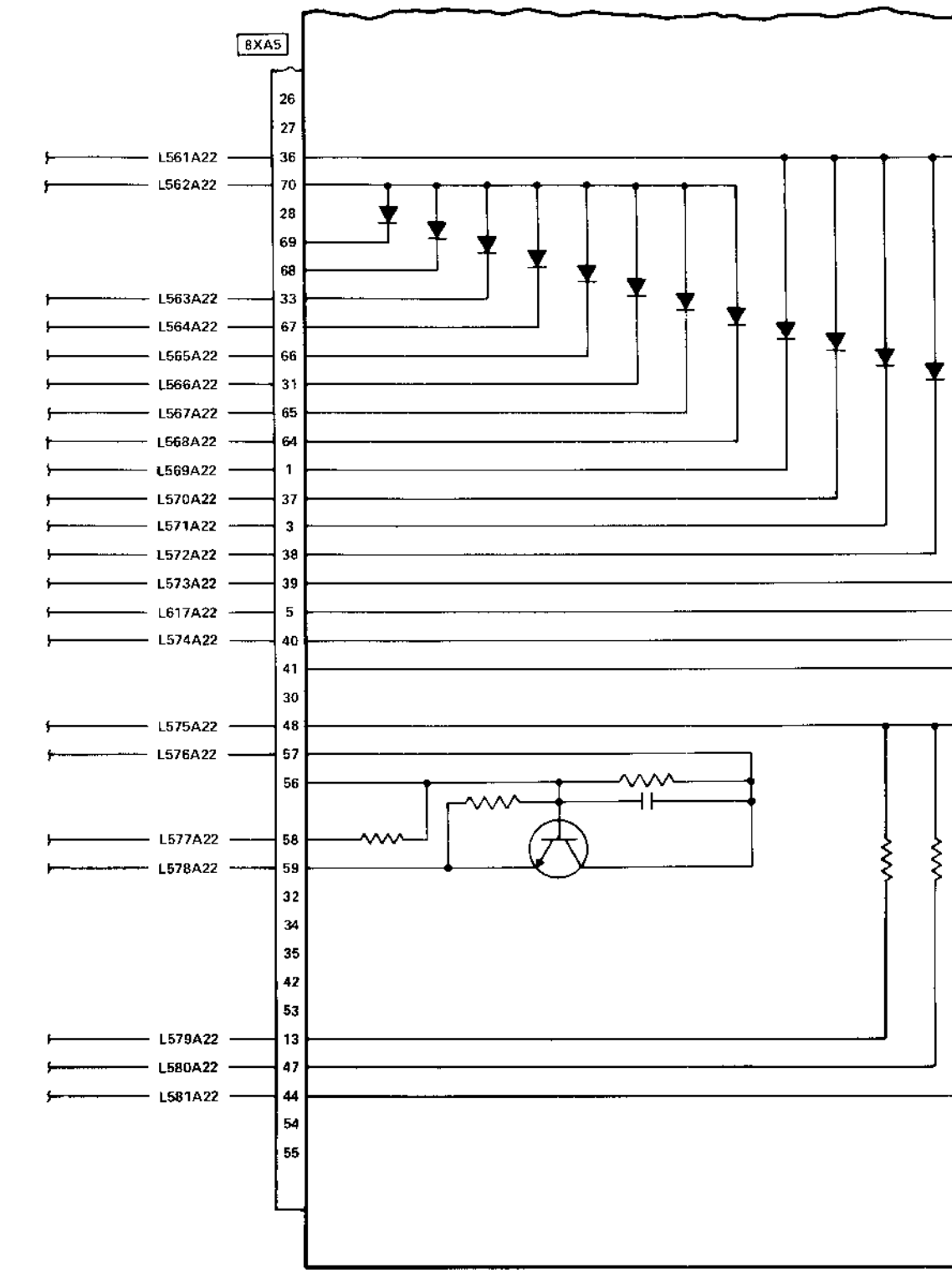



# SOMETHING WRONG WITH THIS MANUAL?

THEN... JOT DOWN THE DOPE ABOUT IT ON THIS FORM, TEAR IT OUT, FOLD IT AND DROP IT IN THE MAIL!

FROM: (YOUR UNIT'S COMPLETE ADDRESS)  
 PFC JOHN DOE  
 COA, 3<sup>d</sup> ENGINEER BN  
 FT. LEONARD WOOD MO 63108  
 DATE

PUBLICATION NUMBER: TM 55-1520-236-23-4  
 DATE: 8 May 1980  
 TITLE: AVIM/AVUM Maint Manual - AH-1S (PROD), (ECAS), (MODERNIZED COBRA)

BE EXACT... PIN-POINT WHERE IT IS				IN THIS SPACE TELL WHAT IS WRONG AND WHAT SHOULD BE DONE ABOUT IT:
PAGE NO.	PARA-GRAPH	FIGURE NO.	TABLE NO.	
6	2-1 a			In line 6 of paragraph 2-1a the manual states the engine has <u>6</u> cylinders. The engine on my set only has <u>4</u> cylinders. Change the manual to show <u>4</u> cylinders.
81		4-3		Callout 16 on figure 4-3 is pointing at a <u>bolt</u> . In the key to fig. 4-3, item 16 is called a <u>skim</u> . Please correct one or the other.
125	line 20			Ordered a gasket, item 19 on figure B-16 by NSN 2910-00-762-3001. I got a gasket but it doesn't fit. Supply says I got what I ordered, so the NSN is wrong. Please give me a good NSN.

TEAR ALONG DOTTED LINE

SAMPLE

TYPED NAME, GRADE OR TITLE, AND TELEPHONE NUMBER  
 JOHN DOE, PFC (268) 317-7111

SIGN HERE:  
 John Doe

FILL IN YOUR  
UNIT'S ADDRESS

FOLD BACK

DEPARTMENT OF THE ARMY

POSTAGE AND FEES PAID  
DEPARTMENT OF THE ARMY  
000-314

OFFICIAL BUSINESS  
PENALTY FOR PRIVATE USE, \$300

Commander:  
U.S. Army Support and Aviation  
Material Readiness Command  
ATTN: DRSTS-MTPS  
4300 Goodfellow Boulevard  
St. Louis, Mo. 63120

TEAR ALONG DOTTED LINE

FOLD BACK



# SOMETHING WRONG WITH THIS MANUAL?

THEN... JOT DOWN THE DOPE ABOUT IT ON THIS FORM, TEAR IT OUT, FOLD IT AND DROP IT IN THE MAIL!

FROM: (YOUR UNIT'S COMPLETE ADDRESS)

DATE

PUBLICATION NUMBER

TM 55-1520-236-23-4

DATE

8 May 1980

TITLE

AVIM/AVUM Maint Manual - AH-1S (PROD), (ECAS), (MODERNIZED COBRA)

BE EXACT... PIN-POINT WHERE IT IS

IN THIS SPACE TELL WHAT IS WRONG AND WHAT SHOULD BE DONE ABOUT IT:

PAGE NO.

PARA-GRAPH

FIGURE NO.

TABLE NO.

TEAR ALONG DOTTED LINE

TYPED NAME, GRADE OR TITLE, AND TELEPHONE NUMBER

SIGN HERE:

FILL IN YOUR  
UNIT'S ADDRESS

FOLD BACK

DEPARTMENT OF THE ARMY

POSTAGE AND FEES PAID  
DEPARTMENT OF THE ARMY  
000-314

OFFICIAL BUSINESS

PENALTY FOR PRIVATE USE, \$300

Commander  
US Army Troop Support and Aviation  
Material Readiness Command  
ATTN: DRSTS-MTPS  
4300 Goodfellow Boulevard  
St. Louis, MO 63120

TEAR ALONG DOTTED LINE

FOLD BACK





THEN... JOT DOWN THE DOPE ABOUT IT ON THIS FORM, TEAR IT OUT, FOLD IT AND DROP IT IN THE MAIL!

# SOMETHING WRONG WITH THIS MANUAL?

FROM: (YOUR UNIT'S COMPLETE ADDRESS)

DATE

PUBLICATION NUMBER

TM 55-1520-236-23-4

DATE

8 May 1980

TITLE

AVIM/AVUM Maint Manual - AH-1S  
(PROD), (ECAS), (MODERNIZED COBRA)

BE EXACT... PIN-POINT WHERE IT IS

IN THIS SPACE TELL WHAT IS WRONG AND WHAT SHOULD BE DONE ABOUT IT:

PAGE NO.	PARA-GRAPH	FIGURE NO.	TABLE NO.

TEAR ALONG DOTTED LINE

TYPED NAME, GRADE OR TITLE, AND TELEPHONE NUMBER

SIGN HERE:

FILL IN YOUR  
UNIT'S ADDRESS

FOLD BACK

DEPARTMENT OF THE ARMY

POSTAGE AND FEES PAID  
DEPARTMENT OF THE ARMY  
OOD-314

OFFICIAL BUSINESS  
PENALTY FOR PRIVATE USE, \$300

Commander:  
U.S. Army Support and Aviation  
Material Readiness Command  
ATTN: DRSTS-MTPS  
4300 Goodfellow Boulevard  
St. Louis, Mo. 63120

TEA  
JNG DOTTED LINE

FOLD BACK



# SOMETHING WRONG WITH THIS MANUAL?

THEN... JOT DOWN THE DOPE ABOUT IT ON THIS FORM, TEAR IT OUT, FOLD IT AND DROP IT IN THE MAIL!

FROM: (YOUR UNIT'S COMPLETE ADDRESS)

DATE

PUBLICATION NUMBER

TM 55-1520-236-23-4

DATE

8 May 1980

TITLE

AVIM/AVUM Maint Manual - AH-1S (PROD), (ECAS), (MODERNIZED COBRA)

BE EXACT... PIN-POINT WHERE IT IS

IN THIS SPACE TELL WHAT IS WRONG AND WHAT SHOULD BE DONE ABOUT IT:

PAGE NO.	PARA-GRAPH	FIGURE NO.	TABLE NO.
----------	------------	------------	-----------

TEAR ALONG DOTTED LINE

TYPED NAME, GRADE OR TITLE, AND TELEPHONE NUMBER

SIGN HERE:

FILL IN YOUR  
UNIT'S ADDRESS

FOLD BACK

DEPARTMENT OF THE ARMY

POSTAGE AND FEES PAID  
DEPARTMENT OF THE ARMY  
DOD-314

OFFICIAL BUSINESS  
PENALTY FOR PRIVATE USE, \$300

Commander:  
U.S. Army Support and Aviation  
Material Readiness Command  
ATTN: DRSTS-MTPS  
4300 Goodfellow Boulevard  
St. Louis, Mo. 63120

T... ALONG DOTTED LINE

FOLD BACK

# The Metric System and Equivalents

## Linear Measure

1 centimeter = 10 millimeters = .39 inch  
 1 decimeter = 10 centimeters = 3.94 inches  
 1 meter = 10 decimeters = 39.37 inches  
 1 dekameter = 10 meters = 32.8 feet  
 1 hectometer = 10 dekameters = 328.08 feet  
 1 kilometer = 10 hectometers = 3,280.8 feet

## Weights

1 centigram = 10 milligrams = .15 grain  
 1 decigram = 10 centigrams = 1.54 grains  
 1 gram = 10 decigrams = .035 ounce  
 1 dekagram = 10 grams = .35 ounce  
 1 hectogram = 10 dekagrams = 3.52 ounces  
 1 kilogram = 10 hectograms = 2.2 pounds  
 1 quintal = 100 kilograms = 220.46 pounds  
 1 metric ton = 10 quintals = 1.1 short tons

## Liquid Measure

1 centiliter = 10 milliliters = .34 fl. ounce  
 1 deciliter = 10 centiliters = 3.38 fl. ounces  
 1 liter = 10 deciliters = 38.82 fl. ounces  
 1 dekaliter = .10 liters = 2.64 gallons  
 1 hectoliter = 10 dekaliters = 26.42 gallons  
 1 kiloliter = 10 hectoliters = 264.18 gallons

## Square Measure

1 sq. centimeter = 100 sq. millimeters = .155 sq. inch  
 1 sq. decimeter = 100 sq. centimeters = 15.5 sq. inches  
 1 sq. meter (centare) = 100 sq. decimeters = 10.76 sq. feet  
 1 sq. dekameter (are) = 100 sq. meters = 1,076.4 sq. feet  
 1 sq. hectometer (hectare) = 100 sq. dekameters = 2.47 acres  
 1 sq. kilometer = 100 sq. hectometers = .386 sq. mile

## Cubic Measure

1 cu. centimeter = 1000 cu. millimeters = .06 cu. inch  
 1 cu. decimeter = 1000 cu. centimeters = 61.02 cu. inches  
 1 cu. meter = 1000 cu. decimeters = 35.31 cu. feet

## Approximate Conversion Factors

To change	To	Multiply by	To change	To	Multiply by
inches	centimeters	2.540	ounce-inches	newton-meters	.007062
feet	meters	.305	centimeters	inches	.394
yards	meters	.914	meters	feet	3.280
miles	kilometers	1.609	meters	yards	1.094
square inches	square centimeters	6.451	kilometers	miles	.621
square feet	square meters	.093	square centimeters	square inches	.155
square yards	square meters	.836	square meters	square feet	10.764
square miles	square kilometers	2.590	square meters	square yards	1.196
acres	square hectometers	.405	square kilometers	square miles	.386
cubic feet	cubic meters	.028	square hectometers	acres	2.471
cubic yards	cubic meters	.765	cubic meters	cubic feet	35.315
fluid ounces	milliliters	29.573	cubic meters	cubic yards	1.308
pints	liters	.473	milliliters	fluid ounces	.034
quarts	liters	.946	liters	pints	2.113
gallons	liters	3.785	liters	quarts	1.057
ounces	grams	28.349	liters	gallons	.264
pounds	kilograms	.454	grams	ounces	.035
short tons	metric tons	.907	kilograms	pounds	2.205
pound-feet	newton-meters	1.365	metric tons	short tons	1.102
pound-inches	newton-meters	.11375			

## Temperature (Exact)

°F	Fahrenheit temperature	5/9 (after subtracting 32)	Celsius temperature	°C
----	------------------------	----------------------------	---------------------	----

